

Applicable project numbers (right of way and construction) are to be shown in the proper blocks. The names and phone numbers, including area code, and District, if applicable, of the following persons are to be shown in the upper left corner: Project Manager: (VDOT), Surveyed By: (L&D Survey Office Manager or Consultant Survey

Project Manager), Design Supervised By: (Design Engineer in Responsible Charge) and Designed By (Designer)

Symbols are to be used to provide an obvious delineation of the courses. Pavement courses are to be shown in accordance with the CADD Manual.

Ultimate sections are to be shown and clearly noted and delineated where applicable.

When placing and rolling flexible pavements, it is impossible to construct sides in a vertical plane without using forms. To make our drawings more realistic, show the side slopes at 1:1 as shown below. Do not denote the slope or the horizontal dimension on the Typical Section. When computing quantities, no adjustment is to be made.

Projects without paved shoulders require a 1 foot wide "wedge" in accordance with [IIM LD-158](#).

Typical Method of Grading Subsurface Material at High Side of Superelevated Curves with Shoulders Graded in Accordance with St'd. GS-11.

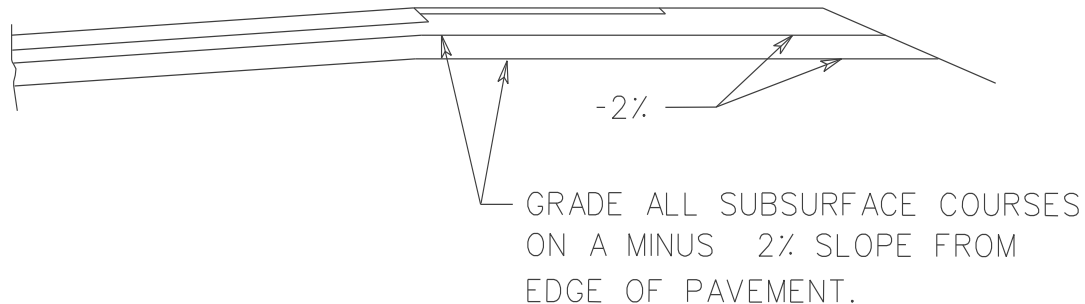

Bottom line of grading below pavement is to be parallel to pavement slope.

HYDROLOGIC DATA SHEET (SEE CHAPTER 2H, FIGURE 2H-7 & FIGURE 2E - 13*)

A Hydrologic Data Sheet is to be included in each applicable set of plans. The blank sheet is available in the Insertable Sheet directory. The drainage designer will furnish the project designer the data needed to fill in the Hydrologic Data Sheet at field inspection stage and again upon final completion of the drainage design. The project designer shall check with the drainage designer at this time to verify that the required water level information is shown on the profile sheets of the roadway plans.

* Rev. 7/16