

PLAN VIEW CONTINUOUSLY REINFORCED CONCRETE PAVEMENT

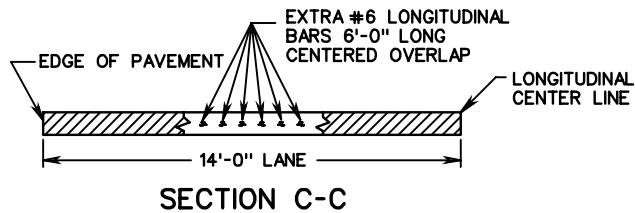

BARS TO BE SECURELY FASTENED TO PREVENT SEPARATION DURING CONCRETE PLACEMENT.

TYPICAL LONGITUDINAL LAP

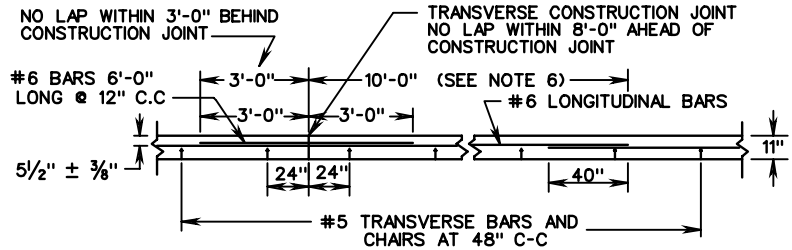
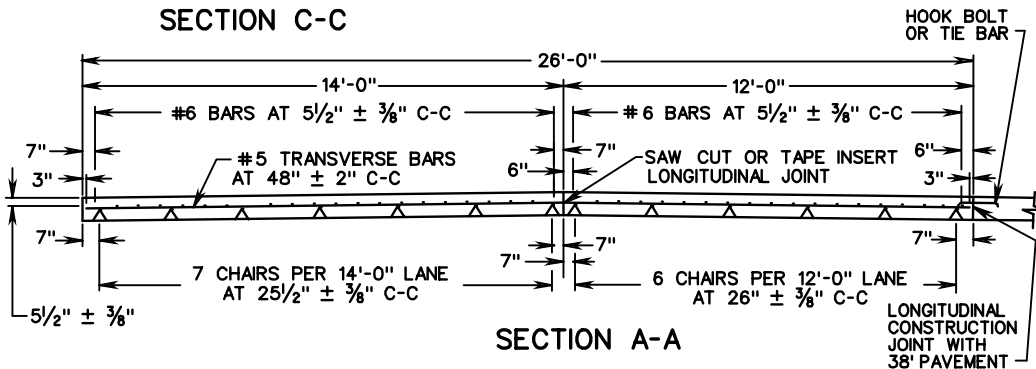

SECTION B-B DOUBLE LAP METHOD

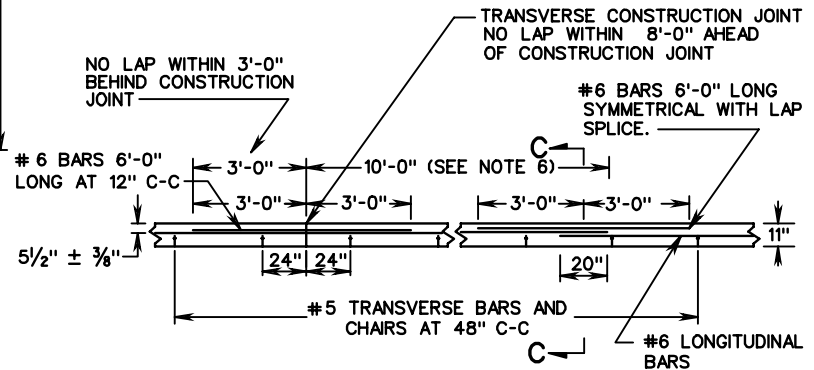

SECTION B-B EXTRA BAR METHOD

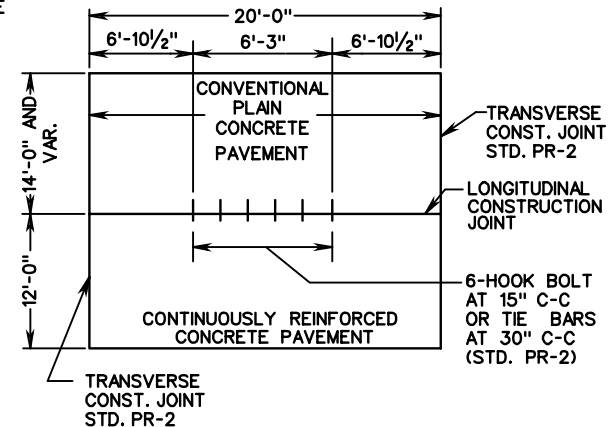

PLAN-RAMP & MAIN LINE CONNECTION

SEE SHEET 3 OF 3 FOR NOTES

SPECIFICATION REFERENCE
316

11" THICK CONTINUOUSLY REINFORCED CONCRETE PAVEMENT 14 FOOT TRAVEL LANE

VIRGINIA DEPARTMENT OF TRANSPORTATION

SHEET 10F 3

301.19