

ALTERNATE CONNECTION

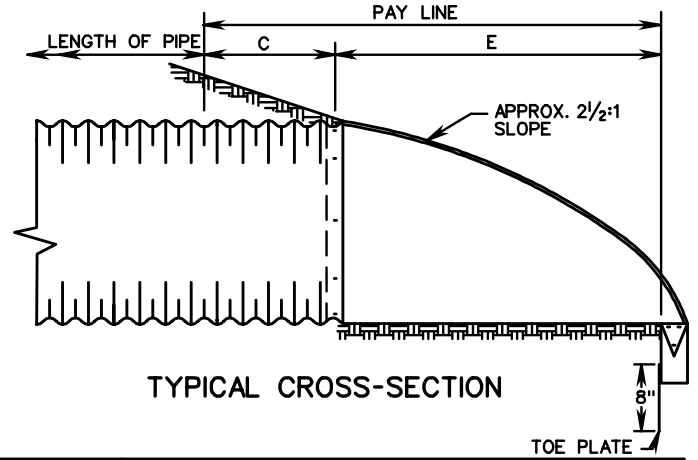

TYPICAL CROSS-SECTION

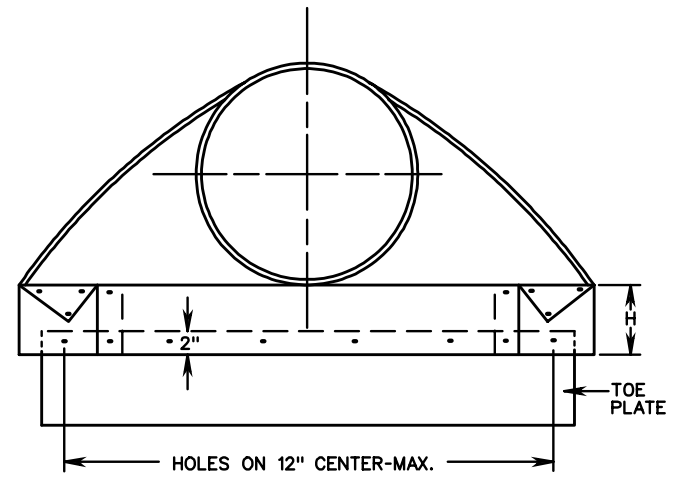

ELEVATION

PIPE DIAMETER	SHEET THICKNESS		DIMENSIONS					
	STEEL	ALUMINUM	A 1" TOL.	B MAX.	H 1" TOL.	E 1/2" TOL.	W 2" TOL.	C
12"	.064"	.060"	6"	6"	6"	21"	24"	24"
15"	.064"	.060"	7"	8"	6"	26"	30"	24"
18"	.064"	.060"	8"	10"	6"	31"	36"	24"
21"	.064"	.060"	10"	12"	6"	36"	42"	24"
24"	.064"	.060"	10"	13"	6"	41"	48"	24"
27"/30"	.064"	.075"	12"	16"	8"	51"	60"	24"
36"	.064"	.075"	14"	19"	9"	60"	72"	36"
42"	.064"	.105"	16"	22"	11"	69"	84"	36"
48"	.064"	.105"	18"	27"	12"	78"	90"	24"
54"	.064"/.079"	.105"	18"	30"	12"	84"	102"	36"
60"	.064"/.079"	.105"/.135"	18"	33"	12"	87"	114"	36"

NOTES:

- TOE PLATE TO BE PUNCHED TO MATCH HOLES IN SKIRT LIP. 3/8" GALVANIZED BOLTS TO BE FURNISHED. LENGTH OF TOE PLATE IS W + 10" FOR 12" TO 30" DIAMETER PIPE AND W + 22" FOR 36" TO 60" DIAMETER PIPE.
- SKIRT SECTION 12" TO 30" DIAMETER PIPE TO BE MADE IN ONE PIECE.
- SKIRT SECTION FOR 36" TO 54" DIAMETER PIPE MAY BE MADE FROM TWO SHEETS JOINED BY RIVETING OR BOLTING ON CENTER LINE, 60" MAY BE CONSTRUCTED IN 3 PIECES.
- CONNECTOR SECTION, CORNER PLATE AND TOE PLATE TO BE SAME SHEET THICKNESS AS SKIRT.
- END-SECTION AND FITTINGS ARE TO BE STEEL FOR USE WITH STEEL PIPE.
- END-SECTION AND FITTINGS ARE TO BE ALUMINUM ALLOY FOR USE WITH ALUMINUM ALLOY PIPE.
- EITHER THE STEEL OR ALLUMINUM END-SECTION DETAILED MAY BE USED FOR PLASTIC PIPE SIZES SHOWN IN ST'D.PC-1 OR AN APPROVED PLASTIC END-SECTION MAY BE USED.
- WHERE FLARED END-SECTION ARE TO BE USED WITH ASPHALT COATED AND PAVED METAL PIPE, END SECTIONS DO NOT NEED TO BE COATED OR PAVED.

SPECIFICATION REFERENCE
302

FLARED END-SECTION FOR 12"-60" CORRUGATED PIPE CULVERTS