

8"X8" OPENING FOR BACKFILL INSTALLATION AT BOTH ENDS OF BOX CULVERT

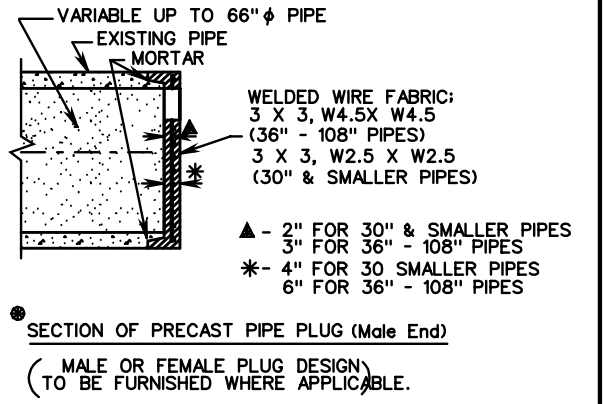
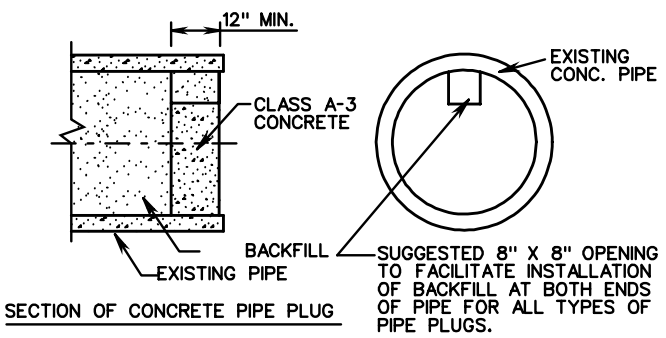
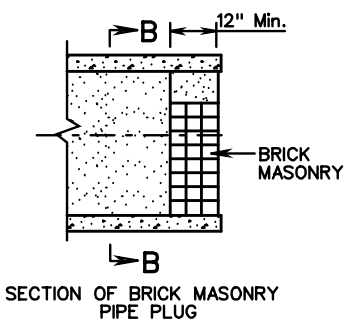
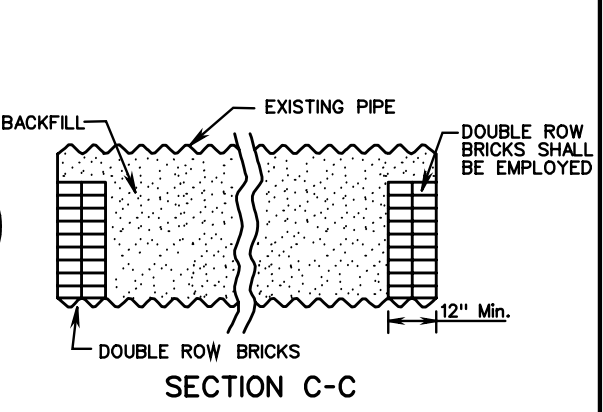
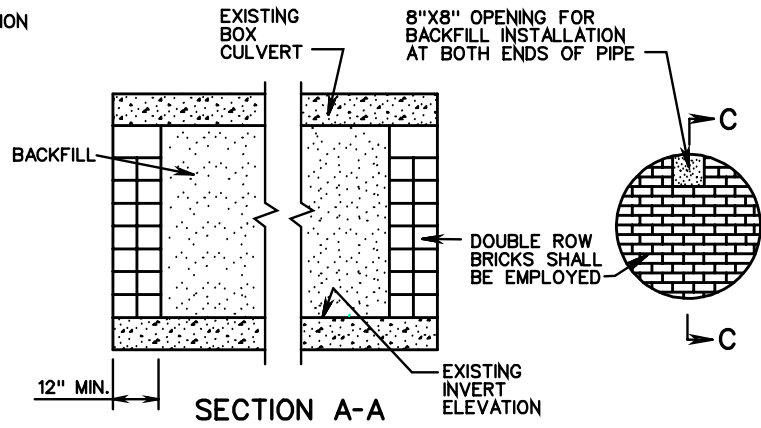
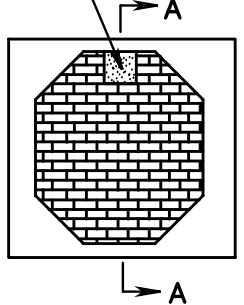

SECTION B-B

NOTES:

BACKFILL IS TO BE EITHER FLOWABLE BACKFILL OR FINE AGGREGATE AS PER THE SPECIFICATIONS AND IS TO BE PAID AS CUBIC YARDS OF FLOWABLE BACKFILL.

FOR PLACEMENT OF STRUCTURES, SEE ROADWAY PLAN SHEETS.

CONCRETE BRICK MAY BE USED IN LIEU OF CLAY BRICK. JUMBO BRICK WILL BE PERMITTED.

● PRECAST NOTES :

CONCRETE TO BE 4000 P. S. I. MIN. COMPRESSIVE STRENGTH.

CONCRETE AND REINFORCING STEEL SHALL BE IN ACCORDANCE WITH AASHTO M170.

DETAIL SHOWN FOR PRECAST PLUG IS REPRESENTATIVE ONLY, OTHER MANUFACTURER'S DESIGN WILL BE ACCEPTABLE UPON APPROVAL BY THE ENGINEER.

QUANTITIES		
PIPE SIZE	CU.YDS BACKFILL PER LINEAR FOOT	CU.YDS PER EACH CONC. PLUG
12"	0.029	.013
15"	0.045	.029
18"	0.065	.049
24"	0.116	.100
30"	0.182	.166
36"	0.262	.246
42"	0.356	.340
48"	0.465	.449
54"	0.589	.573
60"	0.727	.711
66"	0.880	.864
72"	1.047	1.031
78"	1.229	1.213
84"	1.425	1.409
90"	1.636	1.620
96"	1.862	1.846
102"	2.102	2.086
108"	2.356	2.340