

SIGN ATTACHMENT TO TRUSS-TYPE STRUCTURES

SIGN HANGER ERECTION DETAIL WITH LUMINAIRE

(WHEN NO LUMINAIRE RETRIEVAL SYSTEM IS REQUIRED)

ALUMINUM SIGN HANGER W4 X 3.06 PLACED NO GREATER THAN 2' 3" FROM THE LEFT AND RIGHT EDGES OF SIGN PANEL AND THEN SPACED 4' 6" O.C. MAXIMUM.

TOP OF SIGN SHALL BE TILTED TOWARDS TRAFFIC SO THAT THE SIGN FACE IS 3° FROM VERTICAL.

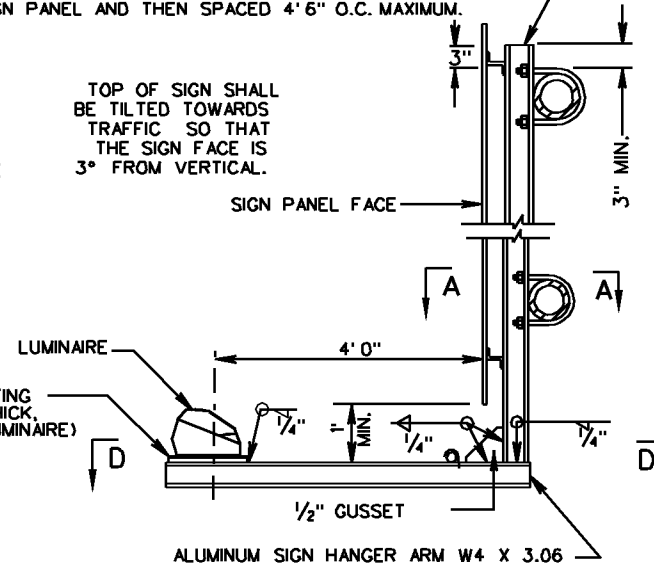

NOTE

LUMINAIRES REQUIRED WHERE INDICATED ON THE PLANS.

LUMINAIRE TO BE ATTACHED TO MOUNTING BRACKET WITH FOUR, 3/8" DIA. GALVANIZED CAP SCREWS, LOCKWASHERS AND NUTS.

SECTION A-A

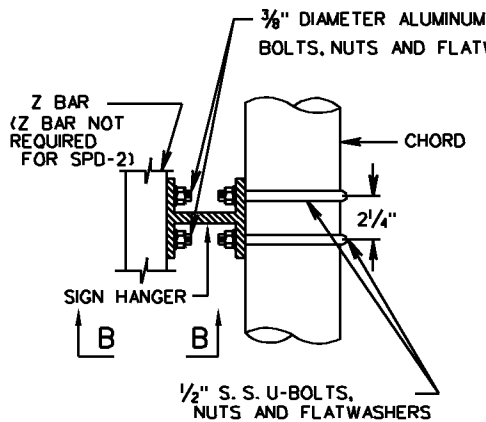

SECTION B-B

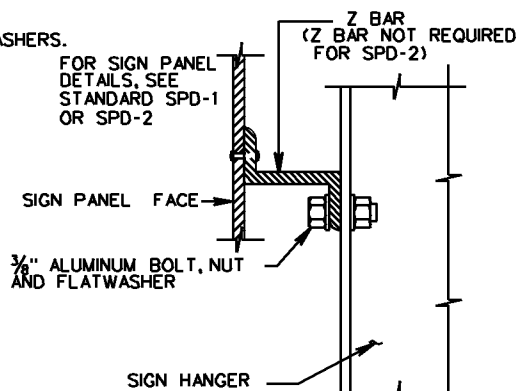

SECTION D-D

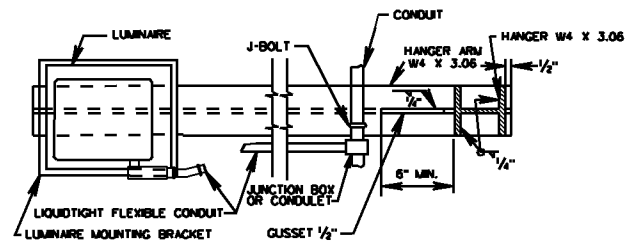

ROAD AND BRIDGE STANDARDS

SHEET 7 OF 7

REVISION DATE
6-15-09

1324.16

OVERHEAD SIGN STRUCTURE

HANGER AND LUMINAIRE DETAIL

VIRGINIA DEPARTMENT OF TRANSPORTATION

SPECIFICATION
REFERENCE

700