

MEDIAN WITH CUT-THROUGH
TYPE M2

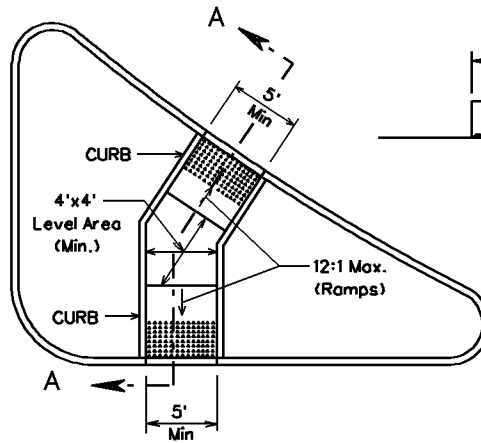

REFUGE ISLAND WITH RAMPS
TYPE R12

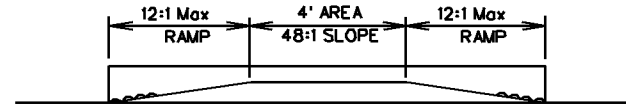

SECTION A-A
TYPE R12 AND M1

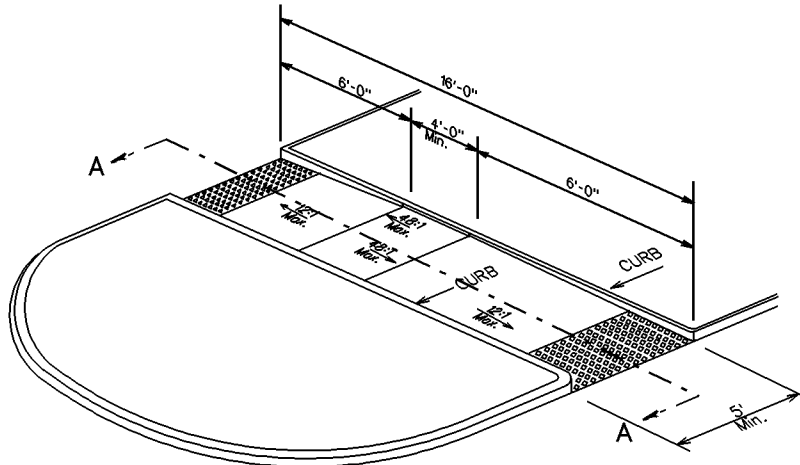

MEDIAN WITH RAMP
TYPE M1

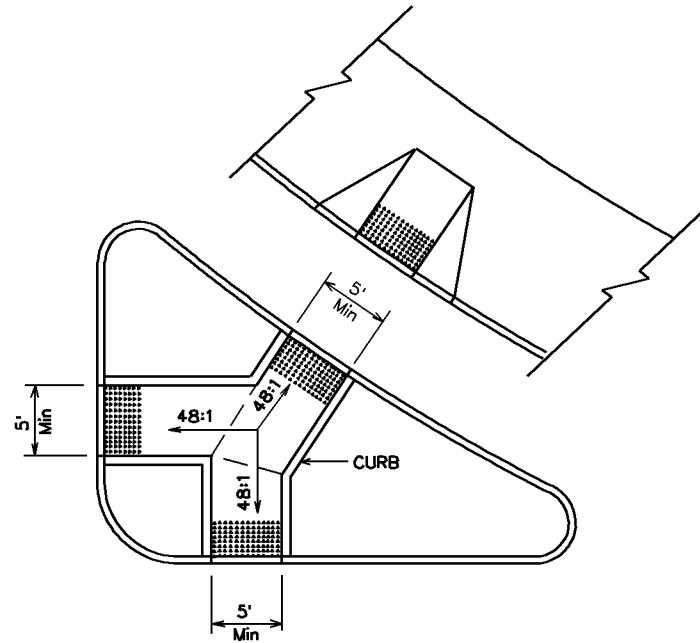

REFUGE ISLAND CUT - THROUGH
TYPE R11

NOTE: FOR GENERAL NOTES ON THE DETECTABLE WARNING SURFACE,
SEE SHEET 1 OF 5.
CURB SHALL BE SHAPED TO MATCH THE FACE OF ROADWAY CURB.

VDOT ROAD AND BRIDGE STANDARDS	
SHEET 5 OF 5	REVISION DATE
203.08A	New 4/09

CG-12 DETECTABLE WARNING SURFACE
MEDIAN AND REFUGE ISLAND APPLICATIONS
VIRGINIA DEPARTMENT OF TRANSPORTATION

SPECIFICATION REFERENCE
105 502