

INSERTABLE SHEET A143

SB-1 PC

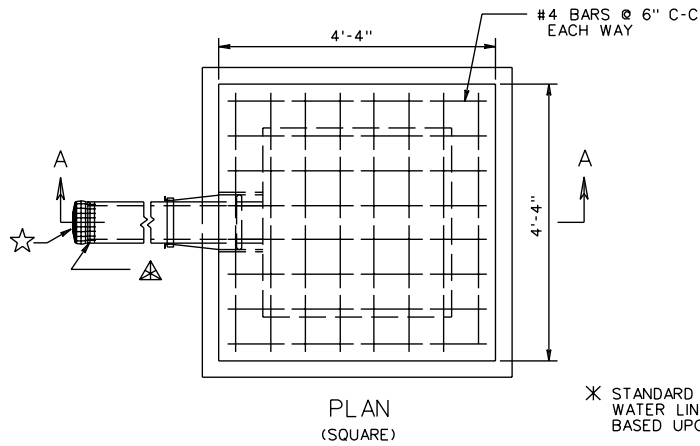

- ☆ 3/4" x 3/4" MESH HARDWARE CLOTH, MIN. 17 GAUGE GALVANIZED AFTER WEAVING.
- ▲ CRIMP AROUND OUTLET END OF PIPE AND SECURE TO PIPE WITH GALVANIZED STEEL WIRE.

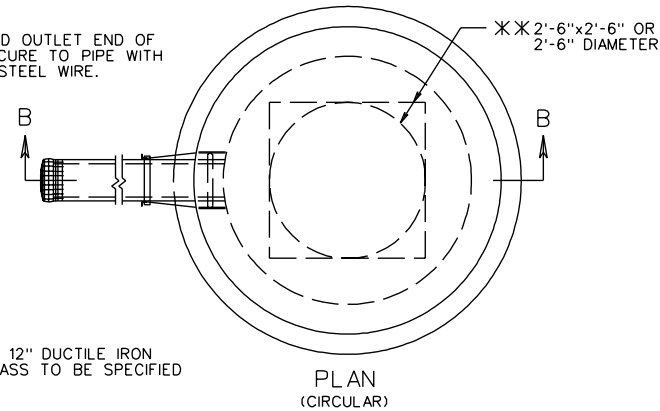

* STANDARD RECOMMENDED PIPE IS 12" DUCTILE IRON WATER LINE, PUSH ON JOINTS, CLASS TO BE SPECIFIED BASED UPON HEIGHT OF COVER.

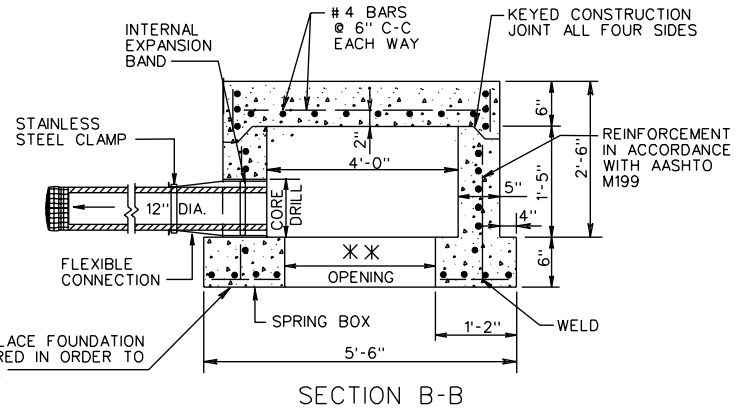
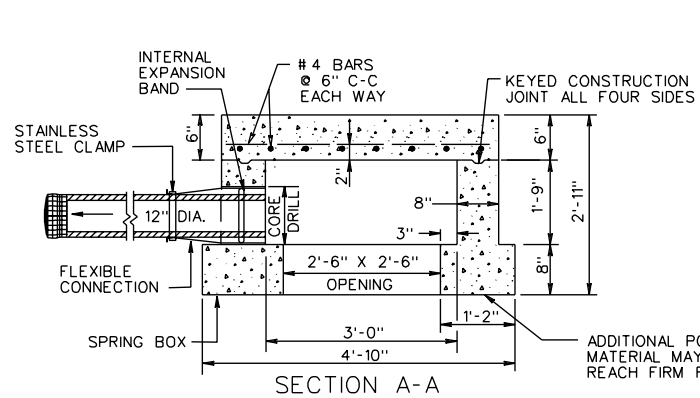

ADDITIONAL POURED IN PLACE FOUNDATION MATERIAL MAY BE REQUIRED IN ORDER TO REACH FIRM FOUNDATION.

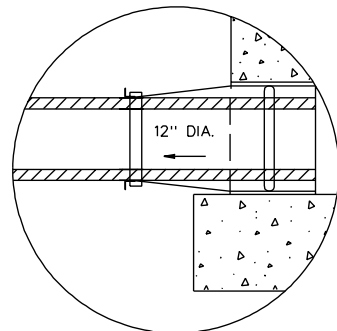

NOTES:

CONCRETE TO BE 4000 PSI MINIMUM COMPRESSIVE STRENGTH.

REINFORCING STEEL IN ACCORDANCE WITH A.S.T.M. A-615 (REINFORCING BARS).

PIPE(S) SHALL BE CONNECTED TO SPRING BOX WITH A FLEXIBLE BOOT MEETING ASTM SPECIFICATION C-923. COST OF FLEXIBLE CONNECTION TO BE INCLUDED IN BID PRICE FOR SPRING BOX. BOOT SHALL BE MADE FROM NEOPRENE RUBBER AND HAVE A 3/8" MINIMUM WALL THICKNESS THROUGHOUT. THE INTERNAL EXPANSION BAND TO SECURE THE BOOT IN PLACE SHALL CONFORM TO ALUMINUM MATERIAL SPECIFICATION 6061-T6. THE EXTERNAL BAND TO CLAMP AND SEAL THE BOOT TO THE PIPE SHALL BE STAINLESS STEEL-CORROSION RESISTANT CONFORMING TO ASTM SPECIFICATION A-167. THE OPENING TO RECEIVE THE FLEXIBLE CONNECTION SHALL BE CORE DRILLED AND IS TO BE CONSTRUCTED TO ALLOW FOR LATERAL AND VERTICAL MOVEMENT, AS WELL AS ANGULAR ADJUSTMENT THRU 20 DEGREES. ALL FIELD INSTALLATION OF PIPE TO SPRING BOX USING FLEXIBLE BOOT SHALL BE COMPLETED IN ACCORDANCE WITH THE MANUFACTURER'S RECOMMENDATIONS AND SPECIFICATIONS.

DIMENSIONS SHOWN ARE MINIMUM. ACTUAL MEASUREMENTS MAY VARY WITH MANUFACTURER'S TOLERANCES.

SPECIFICATION REFERENCE

105

PRECAST SPRING BOX

VIRGINIA DEPARTMENT OF TRANSPORTATION

REV. 7/01

110.02