

\$DGN#  
\$DGNLEV

\$REF001  
\$LEV001

\$REF002  
\$LEV002

\$REF003  
\$LEV003

\$REF004  
\$LEV004

\$REF005  
\$LEV005

\$REF006  
\$LEV006

SURVEYED BY \_\_\_\_\_  
SUPERVISED BY \_\_\_\_\_  
DESIGNED BY \_\_\_\_\_

DESIGN FEATURES RELATING TO CONSTRUCTION OR TO REGULATION AND CONTROL OF TRAFFIC MAY BE SUBJECT TO CHANGE AS DEEMED NECESSARY BY THE DEPARTMENT

REVISED	STATE	FEDERAL AID		STATE		SHEET NO.
		PROJECT	ROUTE	PROJECT	PROJECT	
	VA.					

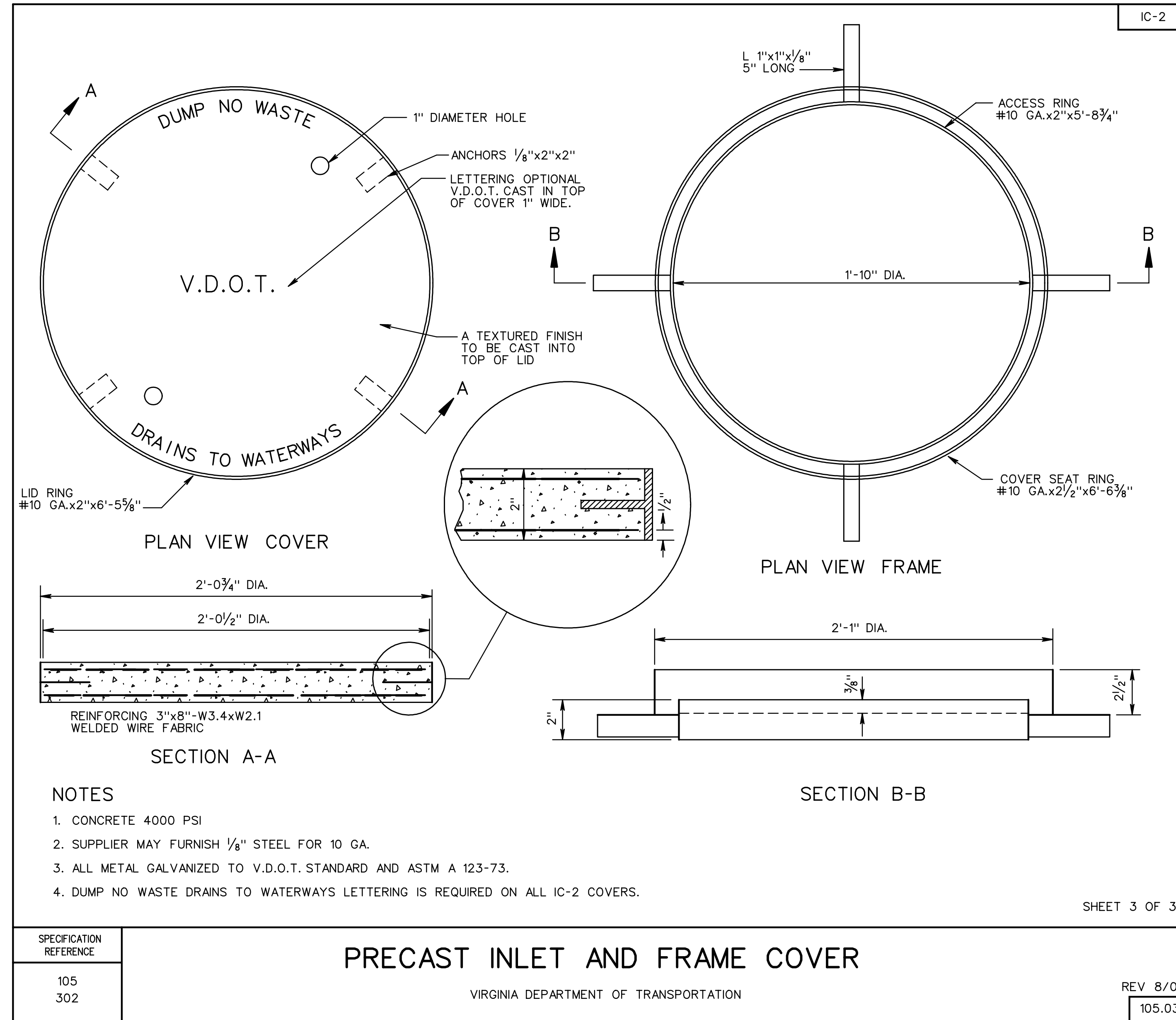

\$TIME\$STAMP\$

NEW 8/07  
SPECIAL DESIGN SECTION  
DRAWING NO. A-192-2

PLAN NO.	PROJECT	FILE NO.	SHEET NO.
----------	---------	----------	-----------