

CHAPTER 4: PLAN DEVELOPMENT

4.1	GENERAL	1
4.2	STEP #1 – ESTABLISH PERFORMANCE CRITERIA	1
4.3	STEP #2 – SELECTION OF EQUIPMENT	1
	4.3.1 Lateral Offsets.....	2
4.4	STEP #3 – SYSTEM CHARACTERIZATION	3
	4.4.1 Check Design Accuracy	5
	4.4.2 The Lighting Design Review	5
4.5	STEP #4 - LIGHTING SYSTEM LAYOUT	5
	4.5.1 Sign Lighting	9
	4.5.2 Signalized Intersection Lighting	10
4.6	STEP #5 - LAYOUT THE CONDUIT AND WIRING SYSTEM	11
4.7	STEP #6 - CALCULATE VOLTAGE DROP, WIRE SIZE, CONDUIT SIZE AND JUNCTION BOX SIZE	14
4.8	STEP #7 – PLAN SHEET DEVELOPMENT	15
	4.8.1 Prepare Base Plan	15
	4.8.2 Plan Sheet Symbols and Call-outs.....	16
	4.8.3 Pole Numbering	20
	4.8.4 Lighting System Survey and Alignment	20
4.9	STEP #8 - DETERMINING SALVAGE AND REMOVAL ITEMS	24
4.10	STEP #9 - DETERMINING QUANTITIES	24
	4.10.1 Conduit, Cable, and Trench	24
	4.10.2 Jacked Pipe/Bored Conduit.....	25
	4.10.3 Pipe Sleeve.....	25
	4.10.4 Electrical Grounding Conductor (EGC)	25
4.11	STEP #10 - PLAN PREPARATION	26
	4.11.1 General	26
	4.11.2 Stand-Alone Traffic Engineering Lighting Plans.....	27
	4.11.3 Lighting Plans Incorporated into a Complete Set of Roadway Construction Plans	28

4.1 GENERAL

The lighting design process includes:

- System characterization
- System layout
- Plan preparation
- Calculation
- Plan sheet development
- Plan quantities
- Plan set completion

These steps are arranged in the order in which they are usually encountered in the design process. The context in which they are presented is that of a completely new design to be accomplished by an individual with an adequate engineering background, but less than average lighting design experience.

4.2 STEP #1 – ESTABLISH PERFORMANCE CRITERIA

The first question the lighting designer should ask is, “Why must this facility be lighted?” The lighting designer should review the lighting warrants and collect preliminary roadway design parameters to determine specific lighting needs. Use the questionnaire in [Appendix VB-1](#) to first understand the needs of the maintaining jurisdiction.

- Discussions with the VDOT Central Office Traffic Engineering Design Section, District Traffic Engineering, and the Resident Engineer will provide an understanding of the priorities concerned with lighting a facility.
- Determine the facility or functional classification of the roadway. Determine the average lighting levels, uniformity ratios, and the required minimum lighting level using the recommendations found in the most current IESNA RP-8 publication.
- The design engineer should try to visit the proposed facility and note the surrounding community. Videotaping and taking pictures of the site is recommended. The designer should also take note of available electrical service locations.

4.3 STEP #2 – SELECTION OF EQUIPMENT

The initial selection of lighting equipment is developed through open discussion between the VDOT Central Office Traffic Engineering Design Section and the local VDOT personnel. The VDOT District Traffic Engineer may have a general concept on how the facility should be lighted. Together with the Resident Engineer, they best understand the requirements of the residents and the flow of traffic through the facility.

This step is interrelated with the next step, System Characterization.

- The various luminaires used in VDOT roadway applications are discussed in Chapters 2 and 3. The final selection of luminaire type should be suitable for supply by at least three manufacturers.
- The light source size (wattage) and mounting height are directly related. Poles and luminaires should be selected as a combination rather than individually.
- The correct matching of mounting height and offset with the light source size should result in meeting average and minimum illumination levels, and uniformity criteria set forth in the AASHTO and IESNA guides while being responsive to economic and safety criteria.
- Information concerning utilization of the actual light output of a given luminaire at a particular mounting height can be determined from photometric data available from the various lighting equipment manufacturers. An example of one such set of data is shown in Figure 2-1.

4.3.1 Lateral Offsets

The lighting designer should attempt to maintain the position of the luminaire constant with respect to the edge of the travel lane. Inconsistent luminaire placement is a source of distraction to the driver. This same concern applies to pole placement.

The lateral dimension for pole placement, or the distance from the roadway edge to the pole foundation, is largely governed by available right of way, the location of drainage structures and utilities, and safety considerations, such as clearance to overhead power lines and guidelines for clear zone.

For example:

An urban roadway project utilizing architectural lighting may limit the placement of poles with a clear zone requirement of 7.5 feet from the face-of-curb to the face-of-pole, and the location of drainage in the utility strip between the street and the sidewalk. The only feasible location for the poles may be a 2-foot right of way strip located behind the sidewalk.

Setting a consistent lateral offset overrides the priority of designing a lighting system with uniform pole spacing.

Referring to the example noted above:

If the project did not provide for a 2-foot right of way strip behind the sidewalk, the lighting designer may be forced to set the poles in the utility strip in front of the sidewalk. The pole spacing would be varied based on available gaps in the placement of drainage structures. Alternatively, consultation with the drainage designer may provide some compromise on the location of the drainage structures.

The lateral offset of the luminaire is typically based on the optical distribution of the luminaire, the width of the roadway, and the district's maintenance capabilities.

For example:

A wide roadway lighted with conventional (cobrahead) lighting standards may be arranged such that the luminaires are located over the edge of the travel lane. This scenario will require a lane closure and a shoulder closure to change a lamp.

Urban projects consistently locate the luminaire over the curb. This scenario provides excellent visibility of pedestrians entering the roadway.

The following issues should be considered in the selection of a lighting system and setting the lateral offset of the pole and luminaire:

- Conventional (cobrahead) applications: The length of the luminaire arm can be adjusted to correctly locate the luminaire, while adjusting the location of the pole to avoid drainage structures, grade changes, and right of way restrictions. The luminaire arm can also be used to shift the light source over the travel lanes for wide roadways. Lane closures and maintenance of traffic are the major concerns with these lighting systems.
- Offset applications: The luminaire is located at the top of the pole, thus the luminaire offset is the same as the pole offset. The pole is normally set back from the edge of the roadway to avoid a lane/shoulder closure. The lighting designer must verify that the grade is suitable for the selected pole offset. Furthermore, the lighting designer must verify that the maintenance department has a bucket truck capable of servicing the lights. Offset lighting standards located on a steep grade or behind guardrail may require a bucket truck (with extended reach) parked on the shoulder to perform routine maintenance.
- High mast applications: Lighting standards must be set outside the clear zone, or behind guardrail. The lighting designer must recognize the grade around the selected pole location. This area must be accessible to a crane in the event that the luminaire assembly lifting-ring becomes stuck at the top of the pole.

For example:

Although the center of an interchange loop may seem an ideal location for a high mast light pole, roadway designers typically locate a storm-water management pond in this area.

4.4 STEP #3 – SYSTEM CHARACTERIZATION

The first two steps in the design process were primarily judgment decisions related to the selection of the light source, luminaire type, and lighting standard.

In this step, the designer will establish the initial pole spacing. Parameters describing the general lighting system layout will be determined using a calculator referred to as a

roadway optimizer. The roadway optimizer calculator is found in the lighting design software package, AGI32.

The parameters that characterize the lighting system are:

- The luminaire optical distribution
- Luminaire mounting height
- Luminaire offset
- Longitudinal spacing

The objective of running the roadway optimizer is to determine the best luminaires for the lighting project, producing the required lighting at the lowest cost. This goal is met by testing many luminaires from several manufacturers, comparing results, and applying the proposed lighting system configuration to estimate the cost of installation and cost of operation in terms of watts-per-mile.

In accordance with the Virginia State Law, the design engineer should make every effort to reduce glare, spill light, and sky glow.

In order to meet all of these goals, the lighting designer should first:

1. Develop a conceptual lighting plan using “Full Cutoff” fixtures from several manufacturers.
2. Once the design parameters related to installation, maintenance and energy costs are recognized, alternatives should be developed using “Cutoff” and “Semi-Cutoff” fixtures.

The following should be considered when using the roadway optimizer calculator:

- The calculations are based on a straight section of roadway.
- Spacing for curved roadways and interchange loops can be adjusted later in the design process. See the current IESNA RP-8 publication for more information.
- The designer should test luminaires from different manufacturers. Photometric data (“.IES” files) can be acquired from manufacturers.
- The roadway optimizer calculation will determine the *optimal (maximum)* spacing that will meet the current IESNA RP-8 criteria. However, in the next step of laying-out the lighting system, the designer will find it practical to reduce this spacing by 10% to avoid conflicts with drainage structures, overhead power lines, bridge structures, etc. Furthermore, this 10% reduced spacing will allow the construction engineer some leeway in avoiding any unforeseen obstructions encountered during construction.
- The calculator is not suited for use with high mast lighting standards. High mast lighting standards are typically used to illuminate large and complex interchanges including open areas between roadways.

The following roadway geometry parameters can be entered into the roadway optimizer:

- **Roadway width.** It should include the breakdown lanes or shoulders on freeways and expressways. It should cover the roadway width in each direction from face-of-curb to face-of-curb for urban roadways.

- **Number of lanes.** The roadway optimizer will calculate the lighting by running two lines of calculation points in each lane including the travel lanes, breakdown lanes, and shoulders.
- **Median width.** Illumination values are not calculated in this area. If a paved median is available as a breakdown lane, this area should be included in the “roadway width” dimension noted above.
- The **offset** from edge of paved shoulder for freeways and expressways and from face-of-curb for urban roadways should also be entered into the calculator. In AGI32, this parameter relates to the offset of the pole. The luminaire is offset from the pole by the parameter “arm length”, which is set during the selection of the luminaire.

4.4.1 Check Design Accuracy

VDOT policy requires that a lighting design meet the criteria for Illuminance, and Luminance. Small Target Visibility (STV) should be reviewed with the TE/L&D manager. [TEDM Section V – Roadway Lighting, Chapter 2, 2.4.2](#) for further information concerning these criteria.

The roadway optimizer is used to identify a lighting system arrangement capable of meeting the current IESNA RP-8 criteria. The analysis may require several iterations to determine the proper pole height, pole spacing, and luminaire type that will work. Situations that prove difficult in meeting all three criteria should be brought to the attention of the TE/L&D Manager.

4.4.2 The Lighting Design Review

The final step in performing the lighting system characterization is to collect the various alternatives and review them with the TE/L&D Manager. This step must be completed prior to laying out the entire roadway lighting system.

VDOT Traffic Engineering Design Section requires a **Design Memorandum** for each roadway lighting plan. This document should provide the reader with a complete understanding of the various lighting alternatives analyzed in the design process. For example, the document should provide a cost analysis comparing the differences in using a high mast lighting system to conventional lighting standards. Also, the memorandum should note the environmental impact of installing semi-cutoff optics versus full-cutoff. An example design memorandum is provided in [Appendix VB-7](#).

4.5 STEP #4 - LIGHTING SYSTEM LAYOUT

The following discussion provides a sequence of work in developing the roadway lighting plan.

1. The survey for the roadway is imported into the lighting design software. The amount of survey imported can be reduced to show only the roadway edges, guardrail locations, and the location of any potential utility and drainage conflicts.
2. Illumination calculation points are placed on the roadway surfaces including any paved shoulder or the curb & gutter. Calculation grids can be placed along wide sections of roadway in a 10' x 10' matrix as shown in Figures 4-1 and 4-2. Ramps and loops can be evaluated using lines of calculation points that curve and change elevation with the grade of the roadway surface. Two calculation lines should be included in the evaluation of each lane on the ramp.
3. Calculations of pavement luminance and STV should be created using a luminance grid. However, the veiling luminance ratio and STV algorithms are functional only along straight roadway sections.
4. Structures that occlude light, such as overpass bridges, should be added to the model.
 - A separate calculation point grid should be created for any underpass lighting. Luminaire mounting height and wattage typically provide illumination levels twice that of the adjacent roadway. Including these higher values into the statistical analysis of the roadway will result in an inflated overall average illumination.
5. Luminaires are placed along the roadway at the offset and spacing determined during system characterization. Special consideration should be taken regarding the placement of luminaires at decision points such as gore areas and intersections. Recommendations for pole placement in these situations can be found in the current IESNA RP-8 publication.
6. The designer should also pay attention to the placement of roadway luminaires near sign structures. A luminaire located too close to a sign can make the text unreadable due to either excessive reflection or glare.

Traffic engineers working in Virginia have developed the following general rule of thumb for overhead sign structures and large, 2-post ground mounted signs:

- Luminaires should be placed no closer than 50-feet in front of the sign structure.
 - Luminaires should be placed no closer than 15-feet behind the sign structure.
7. The following guidance is provided concerning exact location of lighting poles:
 - The exact locations of light poles may be adjusted during construction to avoid obstructions encountered in the field. Features such as solid rock, power lines, slopes, existing guardrail, etc., may make it necessary to locate the pole differently than as indicated in the plans.
 - Construction engineers and inspectors must understand that shifting a single light pole will cause not only a dark area over the increased spacing, but will also cause a bright spot on the pavement where poles are too closely spaced. The

driver's eyes cannot adapt to drastic changes and thus may not see a potential hazard.

- The lighting designer must recognize that these seemingly minor field adjustments to pole placement will undoubtedly occur during construction. Reducing the pole spacing by 10% from the optimum (maximum) luminaire spacing determined during system characterization will allow field adjustment of individual pole locations during construction without adversely affecting the lighting levels. If a change is required during construction, the VDOT construction engineer should consult with the lighting designer to determine if the change requires shifting other light poles in the system.
- When placing light poles near a noise wall, the lighting designer must verify that the pole foundations will not impact the footer for the wall. Furthermore, there should be at least 5 feet of right-of-way available behind the noise wall. This space is necessary to install the pole, foundation, and conduit. More space may be necessary during construction to allow crews enough room to move in trenching and auguring equipment needed to install the lighting system. The designer must also consider access to the lighting poles behind noise walls. Access doors in the wall may be needed to allow maintenance personnel access to the lighting system.
- The designer should note the proposed/existing grade at the pole location. Unsuitable grade may prevent the installation of a pole.
- Every effort should be made to place the lighting pole outside the clear zone. Refer to [TEDM Section V – Roadway Lighting, Chapter 3, 3.4 and 3.5](#) for a more detailed discussion of pole placement and clear zone requirements.

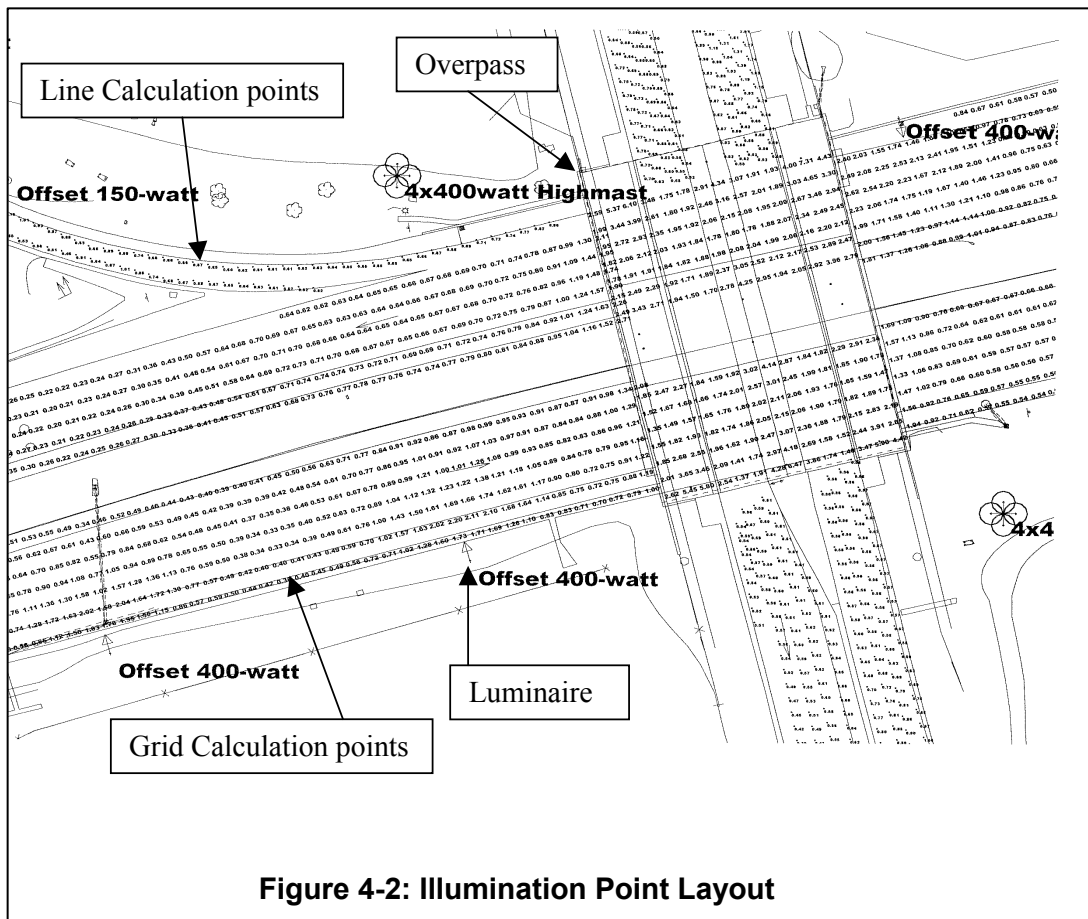
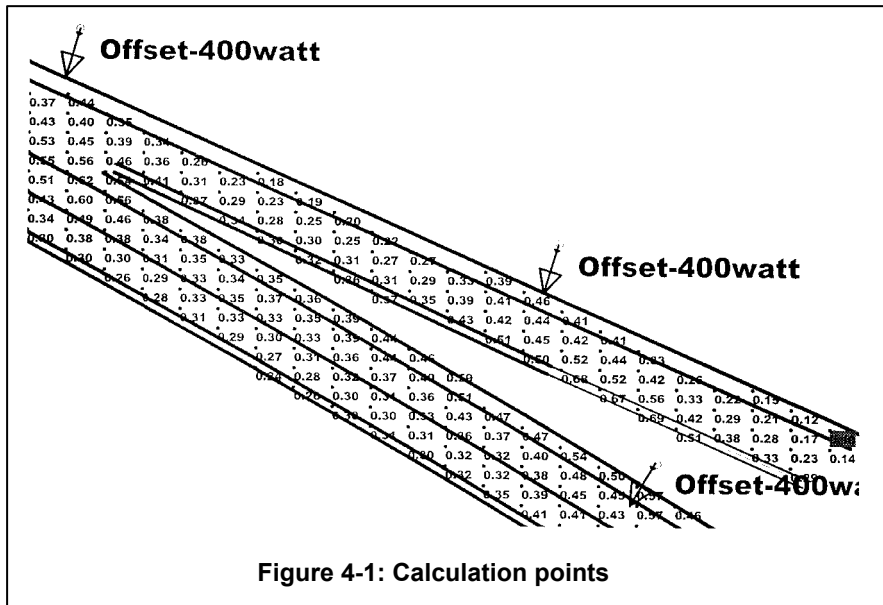

4.5.1 Sign Lighting

In developing the Signing Plans, the roadway lighting designer should utilize the AGI32 lighting design program to recognize the number of luminaires and required spacing of the fixtures. However, if AGI32 is not available, [TEDM Section II - Signing, Appendix IIB-5](#) provides a simple table for the traffic engineer to use in developing the luminaire schedule for a sign structure. In most cases, this table provides an effective substitute for a complete lighting analysis. However, the table becomes inaccurate when an exit panel is placed above the sign. An example of this situation is found in Figure 4-3 and in the [TEDM Section II – Signing, Appendix IIA-8](#).

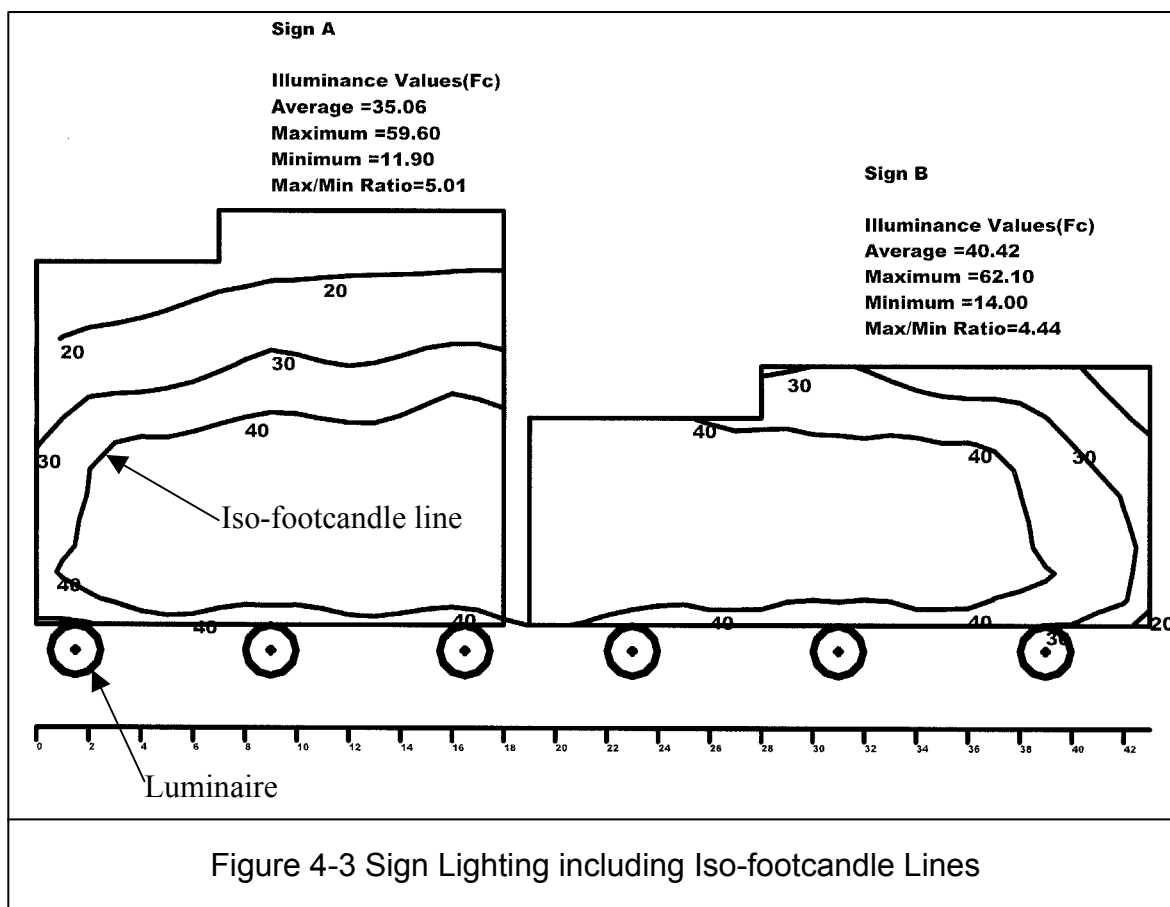

The luminaire arrangement is then passed to the sign designer to be included in the sign elevation plan sheets. The roadway lighting plan should note the sign structure number, luminaire wattage, and electrical phase and circuit as shown in [Appendix VA-5](#).

Sign luminaires are incidental to the cost of the sign and are not included in the roadway lighting cost estimate or summary of quantities.

The sign lighting system for a structure with more than one sign requires the lighting designer to recognize that each luminaire is associated with an individual sign on the structure. Thus, if a sign is removed from the structure at some time in the future, the luminaires associated with that sign would also be removed.

A luminaire retrieval system (brand name: **Lumitrack**) can be used on new overhead sign structures. This system is pre-wired for either 3-wire, single-phase, 120/240-voltage or 4-wire, 3-phase, 277/480-voltage.

Single-phase system: Power distribution to the luminaires alternates:
Line-1, Line-2, Line-1, etc.

Three-phase system: Power distribution to the luminaires alternates:
Phase-A, Phase-B, Phase-C, Phase-A, Phase-B, Phase-C, etc.

For Example:

If a sign structure requires 5 luminaires, the lighting designer must recognize that all three phases should be delivered to the sign. Two of the line phases will be used to power 4 luminaires. The fifth luminaire will be powered by the remaining line phase. The sign plans may show phases evenly distributed as:

Phase-B, Phase-A, Phase-C, Phase-B, Phase-A

4.5.2 Signalized Intersection Lighting

The roadway lighting luminaires associated with a signalized intersection are typically mounted on combination signal poles. As such, their location is fixed by the location of the signal pole. That is, the lighting designer may be able to adjust the bracket arm length, and wattage, but may find that there are limitations on the luminaire orientation and mounting height.

The design of a roadway lighting system that includes an illuminated, signalized intersection should be performed in the following sequence:

1. The signal pole locations should be imported into the lighting design program.
2. An illumination calculation grid is established in the intersection.
3. Luminaires are added to the lighting design. The luminaires, including a bracket arm, are positioned such that the base of the arm is located with the signal pole, and the luminaire is positioned over the intersection. The luminaire should not fall directly above a pedestrian crosswalk. Such a location will not provide sufficient contrast and reduce the overall visibility of the intersection. Effectively, placing a luminaire directly over a crosswalk will result in a washout effect rendering the pedestrian less visible to the driver.
4. Only after the lighting criteria are met for the intersection should the lighting designer begin the task of developing the roadway lighting plan for the roadway adjacent to the intersection.
5. The positions of the signal pole mounted luminaires are passed to the signal designer for inclusion in the Signal Plan.
6. The electrical service plan for the luminaires varies on the preference of the locality.
 - In some cases, the luminaires are installed as part of the roadway lighting system, and the power for the luminaires is metered from the same service as

the roadway lighting. However, the plan should avoid mixing voltages (e.g., a 277-VAC luminaire should not be installed on a signal pole utilizing 120-VAC). In this situation, the signal pole should include a flexible metal conduit to separate the luminaire power from the signal power.

- It is also common to meter the signal pole luminaires from the same service used by the traffic signals.
 - In other situations, the signal pole luminaires may not be metered; rather their energy consumption is accounted for by an umbrella agreement between the power company and the municipality. .
7. The roadway lighting plan should note the wattage of the signal pole mounted luminaires, the bracket arm length, the mounting height, and the electrical service associated with the luminaires.
 8. The luminaire bracket arm is not incidental to the MP-1 Combination Signal Pole and should be included as a pay item on the signal plans. The luminaire also is not incidental to the MP-1 and should be included in the **Roadway Lighting Plan** summary of quantities and cost estimate.

4.6 STEP #5 - LAYOUT THE CONDUIT AND WIRING SYSTEM

The conduit and wiring system is best prepared by plotting the lighting plan on a large-scale plot, as shown in Figure 4-4.

The designer should incorporate the following procedures into the lighting plan:

- The lighting designer should consider running **Jacked Pipe Sleeve** or **Bored Conduit** under existing roadway. This pipe provides a road crossing for any future expansion of the electrical system. Typically the pipe is 6" in diameter and capable of accepting one additional 2" conduit run.
- On new roadway construction projects, a **Pipe Sleeve**, made of a material similar to that used for jacked pipe, should be considered when running conduit under a road. Installing the pipe sleeve during roadway construction rather than jacked pipe after construction will greatly reduce the construction cost associated with the lighting project.
- Junction boxes are placed on either side of jacked pipe or pipe sleeve.
- A junction box should be placed at the base of each overhead sign structure.
- On long, uninterrupted conduit runs, a junction box should be placed every 250 feet to ease in pulling the wire.
- Junction boxes should be placed at the base of each light pole where #0 AWG wires or larger are used to feed power to the pole. For wire sizes #1 or smaller, a transformer base may be used to splice the luminaire wires to the feeder conductors. See [TEDM Section V – Roadway Lighting, Chapter 3, 3.9](#) for a more detailed discussion of transformer bases and [Appendix VB-4](#) for a discussion regarding sizing a junction box.

- Conduit used in roadway lighting is typically no smaller than 2 inches. Conduit used for under bridge lighting systems should be 1 inch or smaller.
- On projects that require the VDOT contractor to install conduit from the local power company service drop to the VDOT meter base and control center, the lighting designer should verify the required conduit size and number with the power company representative.
- Conduit size is based on the NEC 40% fill rule.

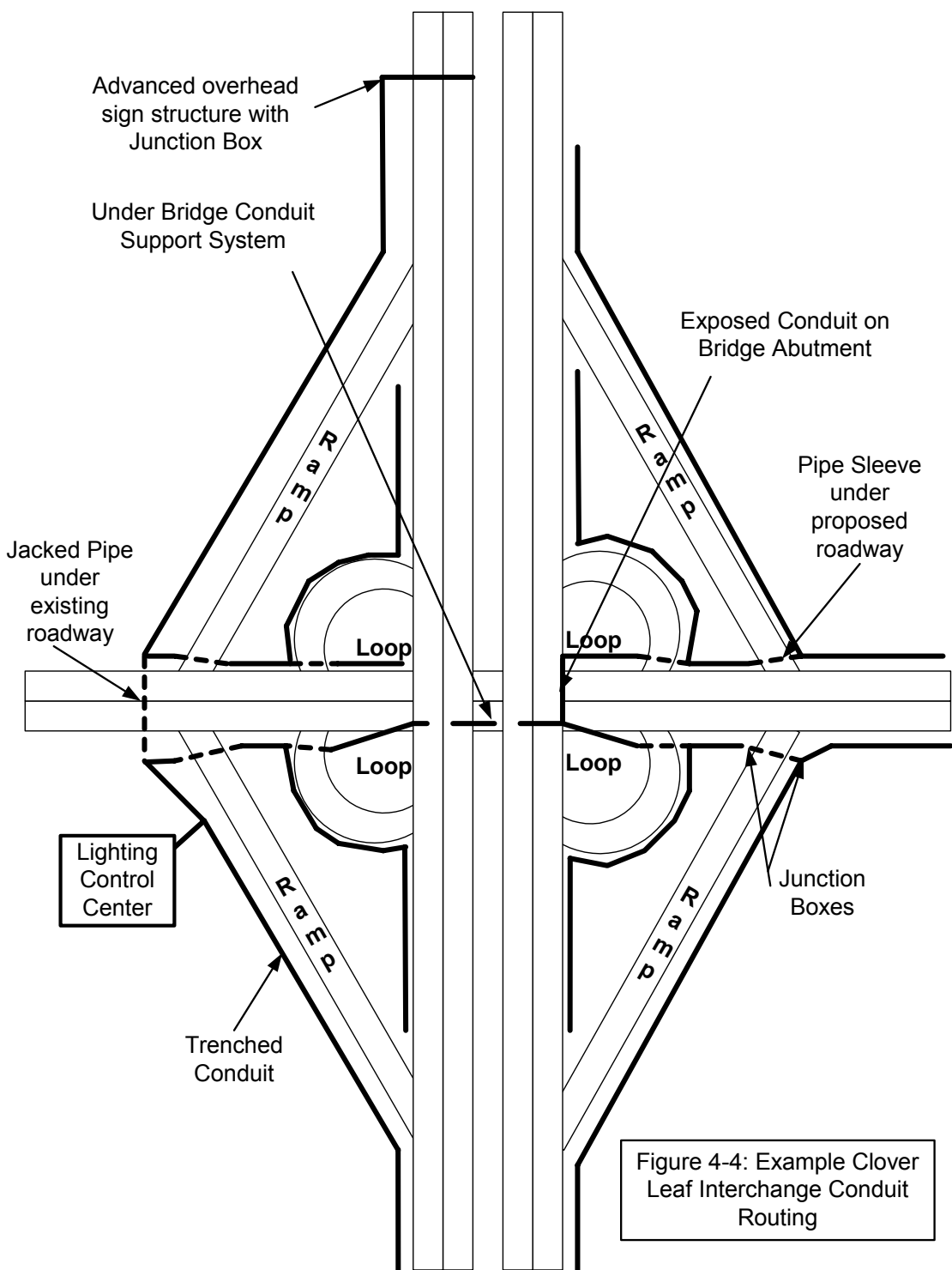

4.7 STEP #6 - CALCULATE VOLTAGE DROP, WIRE SIZE, CONDUIT SIZE AND JUNCTION BOX SIZE

Voltage drop calculations must be performed for the entire roadway lighting system. A full description of the procedures, calculations, and a sample voltage drop spreadsheet are presented in [Appendix VB-4](#). The designer should incorporate the following procedures into the lighting plan:

- VDOT does not require a particular wire size to be used in roadway lighting systems, however, due to issues with tensile strength, #8 conductor cable is the minimum suggested wire size in any feeder or branch circuit.
- Wire sizes over #000 are discouraged, but not prohibited. They are difficult to pull and splice over the long distances associated with roadway lighting projects, especially when the splice point is in a lighting pole transformer base.
- The total voltage drop in all circuits should not exceed 3%. This requirement provides for future expansion of the system and flexibility to make field modifications during construction.
- #10 AWG wire is installed from the base of all lighting standards to the luminaires, including high mast lighting standards that may be as much as 150 feet in height. This wire is incidental to the cost of the luminaire per [VDOT Road and Bridge Specifications, Section 705](#) and not included in the summary of quantities or cost estimate.
- The pole wire is spliced to the branch circuit in the base of the pole. Sufficient space must be allowed in the pole base to make the splice. The NEC provides guidance on volume requirements and junction box sizing. A review of this topic is included in [Appendix VB-4](#).
- #10 AWG wire is installed between the fused safety switch and the luminaires on overhead sign structures. This wire will rise at least 20' and may reach as far as 60' across the roadway. The cost of this wire is incidental to the sign structure.
- The panelboard schedule is created and included in the final plan set. Circuit breaker and contactor sizes are chosen in accordance with NEC requirements and specified on the plans.
- Circuit breakers are intended to protect the conductor cables and contactors. However, NEC requirements state that the circuit breaker ratings not exceed 125% of the normal operating load, except to round up to the nearest commercially available breaker size.

For example:

The total load on a circuit, including ten, 400-watt luminaires at 1.8 amps per fixture, is 18.0 amps. Due to voltage drop considerations, the wire size is a #2 AWG along the first half of the circuit and a #8 AWG over the remaining half of the circuit. The circuit breaker rating should protect the #8 wire (maximum ampacity: 50-amps). However, the circuit breaker rating should not exceed 125% of the normal operating load: ($18 \times 1.25 = 22.5$ -amps). The circuit breaker to be installed in this example should have a 25-amp rating.

- Contactors switch the lights on and off at dusk and dawn in conjunction with the photoelectric cell. On 3-phase control centers, contactors are normally 3-pole with a 277-volt coil. They must have a rating that exceeds the circuit breaker protecting it. Due to the cost of replacing contactors, it is usually best to require a rating far in excess of the normal load. Using the previous example, it would be sufficient to install a 3-pole contactor rated at 60-amps per pole.

4.8 STEP #7 – PLAN SHEET DEVELOPMENT

4.8.1 Prepare Base Plan

The level of detail for a typical lighting base plan when prepared from a roadway construction plan is shown below and in [Appendix VA-5](#).

- Prepare base map in accordance with the VDOT CADD Manual Standards.
- Retain coordinates within CADD file (if possible).
- Check CADD file(s) for corrupt elements.
- Show the locations of underground and overhead utilities.
- Show elements of the existing survey that will impact the installation of light pole foundations and conduit trenching as well as “Finished” roadway elements.
- Perform a field site visit and review plan/profile drawings to ensure that roadway geometry is appropriate for the installation of the lighting system.

“Finished” roadway elements are defined as the combined existing and proposed curb lines, roadway edge of pavement, sidewalks, drainage, curb ramps, etc., as well as, existing and proposed right of way that will be in place when the project is complete.

The base plan sheet includes the following (at a minimum):

- North arrow.
- Graphic Scale.
- Metric logo (as necessary).
- Street names.
- Finished roadway elements (to scale).
- All existing and proposed underground and overhead utilities in place when project is completed.

Existing curb lines and roadway features that are to be removed or relocated during construction may need to be shown on the lighting plans to insure the contractor understands the any potential conflicts. For Example: The Contractor should clearly understand that the plan requires installation of light poles and conduit in an area that was once an asphalt parking lot, but is now planned to be a grassy landscaped area.

4.8.2 Plan Sheet Symbols and Call-outs

Once the entire layout of the roadway lighting plan has been developed; including the location of the light poles, junction boxes, control centers, conduit runs, and wire sizes, the various roadway lighting symbols are added to the plan sheets. Call-outs are placed on the plan sheet indicating each required item to be installed by the contractor. These call-outs and symbols must exactly match the plan pay items. Figures 4-5 and 4-6 provide a simple example of plan sheet symbols and call-outs.

4.8.2.1 Luminaire Call-outs

Each luminaire call-out should include an annotation indicating its source of power. For a 3-phase lighting system, this note should reference the phase, circuit, and control center from which it is fed.

Conventional luminaire call-outs must include a reference to wattage, bracket arm length, and mounting height.

Offset luminaire call-outs must include a reference to wattage, tilt angle, and mounting height. If the tilt angle is the same for all luminaires (e.g., 0-degrees), the angle may be stated in the General Notes or in the plan details. The offset tilt angle written on the plans is referenced to straight down. It is important to note that some lighting manufacturers (in their .IES file) reference the nadir (0-degrees) for their offset luminaires as 45-degrees from straight down. The manufacturer's convention should not be confused with the construction plan's convention of referencing the luminaire tilt angle. This issue should be made very clear to the contractor in the light pole details included with the plan set.

High mast luminaire assembly call-outs must include a reference to wattage and number of luminaires on the assembly. The pole length is frequently included in the luminaire call-out for clarity, however, this annotation may be redundant to the "Pole Type" associated with the pole call-out. If a high mast luminaire must be installed with its optics oriented at a particular bearing, an arrow must be added to the symbol to indicate the luminaire's aiming direction.

4.8.2.2 Pole Call-outs

The pole call-out provides the contractor with a pole location, pole number, and pole type.

- The pole location usually references a survey baseline as explained in TEDM Section V – Roadway Lighting, Chapter 4, 4.8.4.
- TEDM Section V – Roadway Lighting, Chapter4, 4.8.3 provides an example pole numbering convention.

- The pole type refers to the lighting standard pay item and pole length. Refer to [Appendix VB-2](#) for a more complete discussion of VDOT standard pay items.
- The base of each pole symbol must be placed on the plan sheet at its required location and oriented to match the required aiming direction.

For Example:

An LP-1 pole intended to be placed at a specific station & offset should be shown on the plan sheet with the pole base at the required point relative to the baseline. The symbol should then be oriented such that the LP-1 bracket arm and luminaire are aimed in the direction that provides the best illumination of the roadway. Many times this orientation results in placing the bracket arm and luminaire perpendicular to the edge of the curb.

4.8.2.3 Conduit Call-outs

The conduit call-outs must include the size of the conduit (proposed or existing) and/or pipe sleeve, and the number/size of conductor cables. Additional information may be included to clarify circuit connections. For example, the call-out might include an annotation regarding any special requirements such as “Metal”, “Conduit mounted to bridge abutment”, etc.

4.8.2.4 Circuit Details

Some plan sheets may require a more detailed description of the electrical circuitry involved with construction. These details may involve complicated splicing at a junction box. An example of a circuit detail is shown in [Appendix VA-6](#).

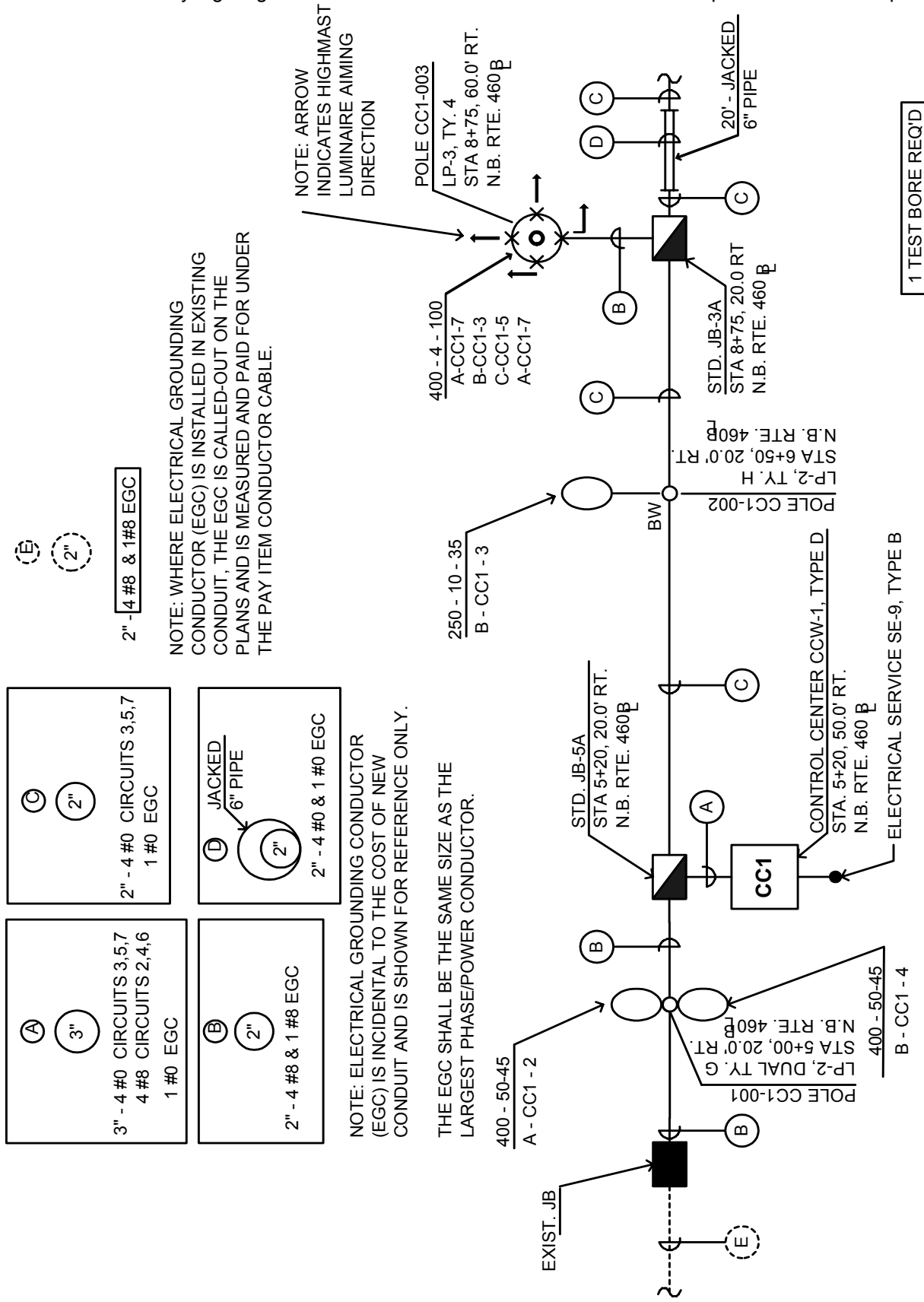
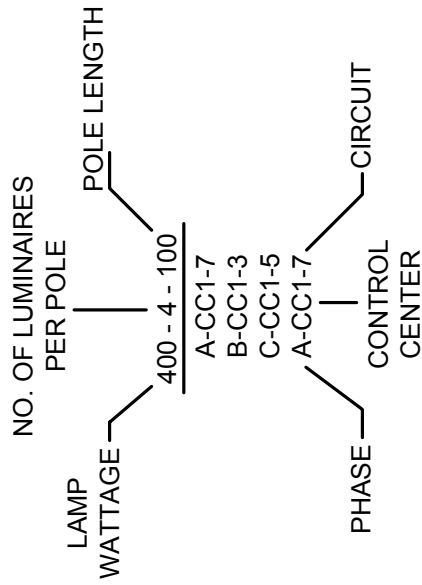
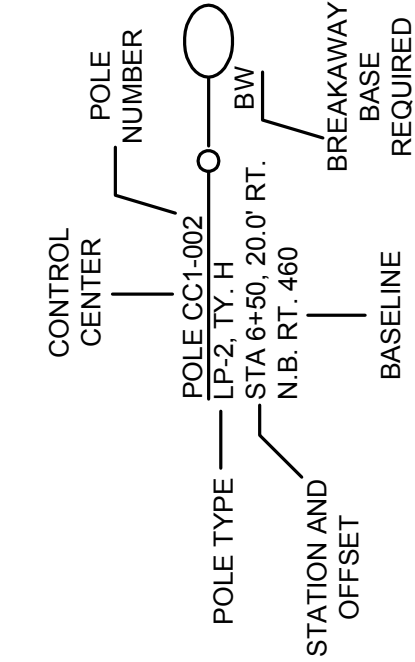

Figure 4-5: Sample Plan Sheet Call-Outs and Symbols



HIGHMAST LUMINAIRE ASSEMBLY



LIGHTING STANDARD

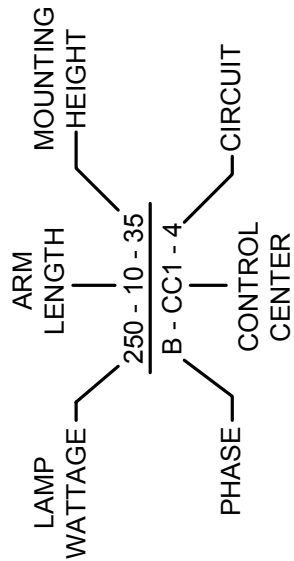

CONVENTIONAL LUMINAIRE

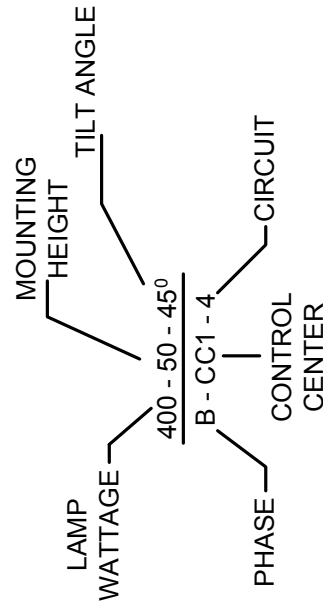

OFFSET LUMINAIRE

Figure 4-6: Sample Luminaire and Lighting Standard Call-Out

4.8.3 Pole Numbering

In development of the final plan set, the location of each light pole is described by a station and offset relative to the survey baseline. However, each lighting standard may also be assigned a unique number. This number is used as a reference during construction.

The following convention provides one example of a pole numbering system:

The pole number should be six digits. The first three digits describe the lighting control center powering the lighting standard. The second three digits increment for each pole on the lighting control center.

Service panel numbers or names do not need to follow any prescribed order or convention. However, pole numbers should increment corresponding to the direction of vehicle travel.

For example:

POLE: CC1-001

POLE: CC1-002

These two poles are powered by lighting control center “CC1”.

The designer should note that changes in the lighting plan that occur during construction will most likely effect any pole numbering system. However, VDOT maintenance personnel will revise the proposed pole numbering system after completion of installation.

4.8.4 Lighting System Survey and Alignment

The Traffic Engineering Design Section of L&D may require a lighting design that is not constructed in conjunction with a roadway construction project. In some cases, the roadway construction project may be nearing completion, and the lighting project may simply utilize the survey and as-built roadway plans. In other situations, the lighting designer may need to acquire full aerial mapping and survey to complete the lighting plan. In either case, a stand-alone lighting project must include a complete set of survey and alignment plan sheets.

4.8.4.1 Survey and Alignment Based on Roadway Construction Plans.

Projects that are constructed during or immediately following a roadway construction project may utilize the roadway construction baselines to establish the light pole locations. This system is used in the example plan sheet presented in [Appendix VA-5](#). For example, a lighting standard is frequently located with a station and offset such as:

STA. 103+15, 35' LT.
RT-460 CONST. B_L

If the lighting plans are not included in the complete set of roadway construction plans, the roadway lighting plan set is considered a stand-alone project and should utilize:

- The **Survey** including existing and proposed roadway alignment.
- The **Proposed Alignment Data Sheets**.
- **Benchmarks**.

4.8.4.2 Stand-Alone Roadway Lighting Projects

Stand-alone lighting projects that require a complete new set of aerial mappings and survey can establish the location of the proposed lighting standards in several ways:

- Option 1. A construction baseline can be established in the same manner as that of a roadway construction project.
- Option 2. Lighting standard locations may also be established using a set of swing ties. Three swing-ties should be established for every standard as shown in Figure 4-7.

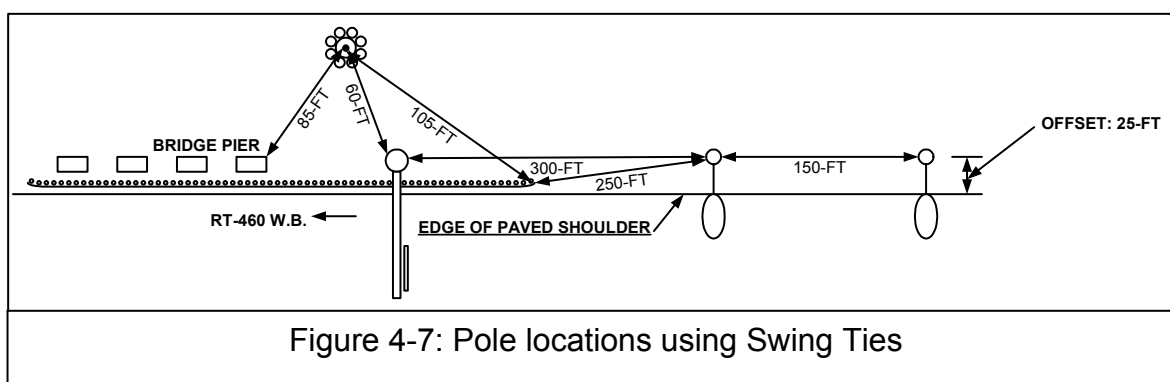

- Option 3. The lighting designer may elect to locate the lighting standards using a coordinate system referenced to the VDOT Project Coordinate System. This system provides the construction surveyor the ability to use a GPS instrument to locate the proposed pole locations and deliver to VDOT the final as-staked (as-built) pole locations. These pole coordinates may be used to develop a pole inventory in a GIS format.

This method is advantageous in cases where the cost of maintenance of traffic to establish baselines may be prohibitive. Also, it may be impractical to expect a surveyor to rely on survey points separated by difficult topography, such as densely wooded ramp systems or high median barriers.

To develop a coordinate system, the lighting designer must direct the surveyor to:

1. Establish a series of Survey Control Points throughout the limits of the project similar to that shown in Figure 4-9. Typically, at least 3 to 5 control points are necessary on any survey. However, on large projects, control points may be needed every 0.5 miles.
2. The Survey Control Points must be requested before beginning the survey. Attempting to establish these control points after the survey crew has left the location may be costly and time consuming.
3. Each Control Point should be based on a set of three “swing-ties” to fixed objects along the roadway or to existing VDOT monuments.
4. The Survey Control Points should be marked with an iron PK nail.
5. The points must be located such that the construction surveyor can easily reference at least two Control Points in locating each proposed lighting standard.

In order to generate the Pole Coordinate Table, similar to Table 4-1, the Microstation operator should be familiar with “tagging elements”.

1. On the lighting plans, light pole symbols (referred to in Microstation as “cells”) are added at their required locations. If the lighting design was developed in AGI32, the luminaire symbols can be exported to Microstation and pole symbols attached to the AGI32 symbols.
2. A Microstation non-graphical tag is placed at the origin of the cell. This origin should be located at the center of the pole, as shown Figure 4-8.
3. Each lighting standard is assigned a unique pole number on the plan sheet, as shown in Figure 4-10.
4. The non-graphical tags and their associated coordinates are then exported to an Excel spreadsheet.
5. The pole numbers are added to the Excel spreadsheet and cross-referenced to the tag coordinates to create the Pole Coordinate Table. The Pole Coordinate Table is included with the complete plan set.

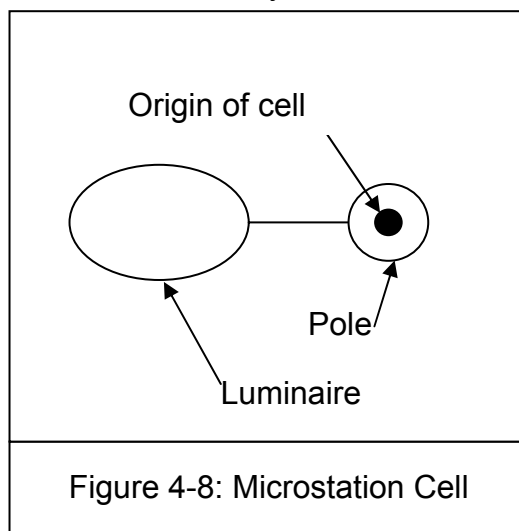

Figure 4-8: Microstation Cell

The complete plan set includes sketches of each Survey Control Point and the Pole Coordinate Table. Any revision to the plans (e.g., shifting a pole 20 feet due to a terrain conflict) requires amending not only the plan sheet, but also the Pole Coordinate Table.

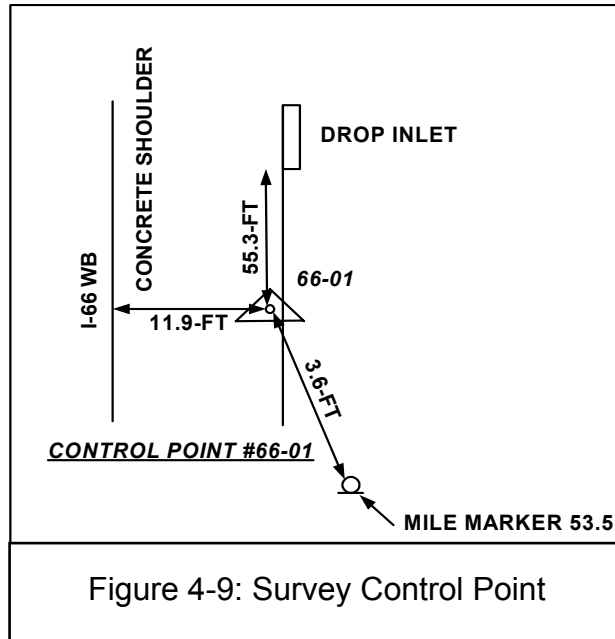
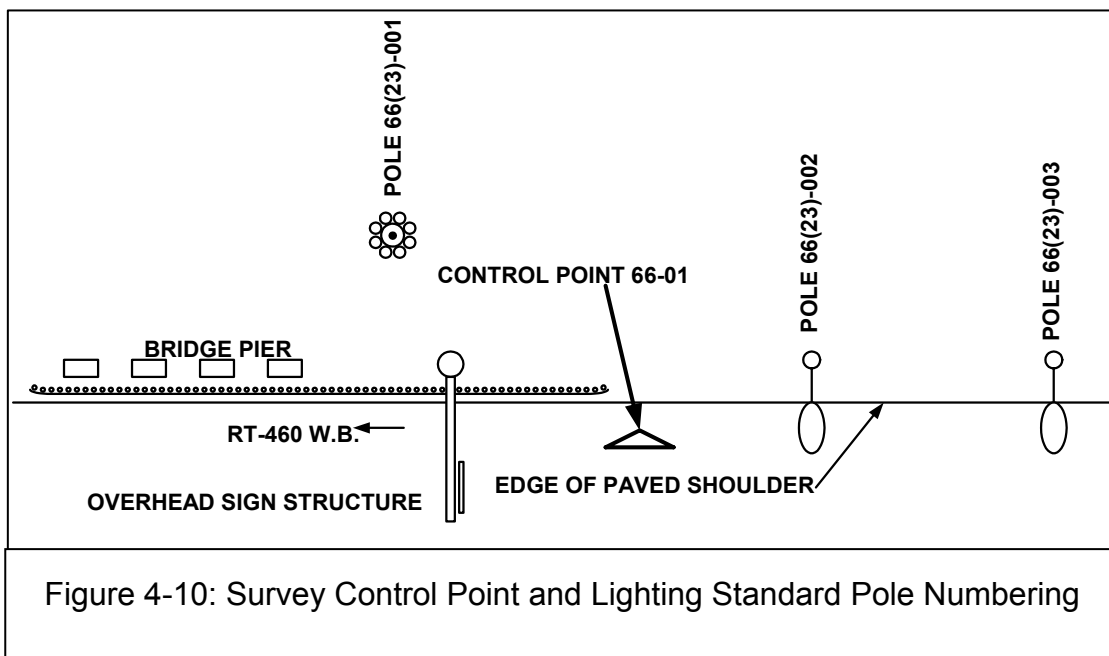

TABLE 4-1 CONTROL CENTER 66(23)		
POLE NUMBER	EASTING	NORTHING
POLE 66(23)-001	3583617.2040	430741.5480
POLE 66(23)-002	3583824.1820	430857.7170
POLE 66(23)-003	3584032.5780	430963.4190
CONTROL POINT #66-01	3583725.1010	430845.0200



4.9 STEP #8 - DETERMINING SALVAGE AND REMOVAL ITEMS

The lighting designer should incorporate all components of the existing lighting system into the proposed lighting plan.

- In most situations, a field review of the site will be the only way to verify the type of roadway lighting currently utilized on the site.
- The engineer should collect all as-built plans of the site.
- The lighting engineer should make every attempt to understand the layout of existing lighting systems and Traffic Management Systems.

Once the lighting designer has a good understanding of the existing lighting system, the District Traffic Engineer must be contacted to determine those items that should be maintained, removed, replaced, modified, or abandoned.

[VDOT Road and Bridge Specifications, Section 510](#) provides procedures for working with existing lighting systems.

4.10 STEP #9 - DETERMINING QUANTITIES

The VDOT Specifications provide measurement and payment for most items in a roadway lighting project. Specific items not covered under the Specifications are addressed through Special Provisions or Special Provision Copied Notes, as referenced in the [TEDM Section 1 – General, Chapter 3, 3.8.](#)

The pay item on the Summary of Quantities sheet should exactly match the standard VDOT pay items. Refer to [Appendix VA-3](#) for an example of a Summary of Quantities Sheet. Refer also to [Appendix VB-2](#) for an explanation of some VDOT standard pay items related to a lighting plan. A current list of standard pay items can be found on the VDOT web site.

The following section describes items that require special attention in calculating estimated quantities.

4.10.1 Conduit, Cable, and Trench

The Summary of Quantities includes the amount of conduit required for each plan sheet. However, in computing the amount of conduit, cable and trenching required on a plan sheet, the lighting designer should make some consideration for cable splices and conduit bends around the various drainage structures and other features found along the roadway, i.e., variation of terrain. Similarly, conductor cable will not lie perfectly straight or flat in the conduit.

The sum totals of the following items should be increased to compensate for variation encountered during construction. The following percentages work well for most projects:

- Conductor cable: increased 10%
- Conduit: increased 5%
- Trench: increased 5%

Conduit example:

Plan Sheet #3: Required amount of 2" conduit: 700-feet. Increase: 35-feet.

Plan Sheet #4: Required amount of 2" conduit: 800-feet. Increase: 40-feet.

Plan Sheet #5: Required amount of 2" conduit: 600-feet. Increase: 30-feet.

Summary of Quantities: Sheet #3: 2" Conduit = 735-feet
 Sheet #4: 2" Conduit = 840-feet
 Sheet #5: 2" Conduit = 630-feet
 Total 2" Conduit = 2,205-feet

4.10.2 Jacked Pipe/Bored Conduit

Trench Excavation is **not** required in areas where Jacked Pipe Sleeve or Bored Conduit is installed.

4.10.3 Pipe Sleeve

The current Specifications and Standards do not cover Pipe Sleeve. A modification to the VDOT Specification must be included in the contract documents in those cases where Pipe Sleeve is required on a lighting plan. The Summary of Quantities should include trenching (ECI-1) wherever Pipe Sleeve is required.

4.10.4 Electrical Grounding Conductor (EGC)

The electrical grounding conductor (EGC) is incidental to the installation of new conduit. That is, there is no separate pay item for the EGC. The lighting designer should not account for any EGC proposed for installation into new conduit. The contractor must include all costs associated with the installation of the EGC with the cost of installing new conduit. However, where conductor cables are pulled through existing conduit, (e.g., retrofit of an existing lighting system, or installation of cables in an existing bridge parapet) the lighting designer should indicate on the plans the requirement to install the correct size EGC. The required length of EGC is added to the quantity of conductor cable.

For example, a plan sheet includes:

New 2" conduit with four, #2 AWG and four, #8 AWG conductor cable = 700-feet.

Existing 2" conduit with four, #2 AWG and four, #8 AWG conductor cable = 50-feet.

Summary of Quantities:

2" Conduit = 700 Linear Feet

#8 Conductor Cable = 4x750' = 3000 Linear Feet

#2 Conductor Cable = (4x750') + 50' (EGC) = 3050 Linear Feet

4.11 STEP #10 - PLAN PREPARATION

4.11.1 General

Depending on the nature of the project, plans will be developed either as stand-alone lighting plans or as part of a complete set of roadway construction plans. The advertisement and construction of a lighting plan varies under these circumstances. A complete discussion of the plan elements for each of these scenarios is included below. [Appendix VA-1 through VA-10](#) provides an example plan set similar to that provided as part of a roadway construction project. The designer should reference the [TEDM Section 1 - General Chapter 3, 3.5, Plan Sheet Format and Number Criteria](#)

The following elements are generally included in every roadway lighting plan set:

Detail sheets that show items unique to the project. Items that are found in the VDOT Road and Bridge Standards should not be shown in the lighting plans unless required for clarification or modification.

For example:

- Under bridge lighting systems
- Special conduit attachments to bridge structures
- Clarification of pole placement relative to guardrail or edge of shoulder
- Panelboard schedule

Each plan sheet should clearly identify the required pay items and include:

- A layout of the roadway and graphical representation of the lighting standard locations, control centers, overhead sign structures, and conduit runs.
- Call-outs with cable/conduit quantities and sizes.
- Luminaire call-outs with wattage, circuit assignments, service panels, mounting height, bracket arm length, and tilt angle.
- Lighting standard call-outs with pole locations (station & offset), pole number, and pole type.
- Junction box type (station & offset is optional).

The following plan sheets are required for both stand-alone plans and plans that are part of a complete roadway construction project:

- **General Notes.** A list of example General Notes is available in [Appendix VB-5](#). The General Notes should include the required lighting criteria (e.g., average illumination, uniformity, etc.) for the project.
- **Summary of Quantities.** An explanation of some VDOT standard pay items is available in [Appendix VB-2](#).
- **Luminaire Details.** This detail sheet should include a diagram of the luminaire and iso-footcandle curves if required for clarification as shown in [Appendix VA-4](#).
- **Typical Pole Details.** This detail sheet may be required for clarification of pole installation as shown in [Appendix VA-4](#).
- **Other Detail Sheets.** These sheets may include specially modified items required for the project, such as a modified electrical service or a special design pole foundation.
- **Legend.** Refer to the example in [Appendix VA-2](#).
- **Under Bridge Lighting System Detail Sheets.** Shown in [Appendix VA-7](#), [VA-8](#) & [VA-9](#). The detail should include the following items:
 - Enlarged plan view of the bridge structure showing luminaire placement and conduit routing.
 - Elevated or section views of the piers or abutments showing luminaire, conduit, and junction box placement.
 - Electrical schematic showing the conductor cable routing and splice points.
- **Panelboard Schedules.** The lighting system designer must provide the circuit breaker size and contactor size. An example is included in [Appendix VA-10](#). A full discussion of circuit breaker and contactor sizing is also provided in [Appendix VB-4](#).

4.11.2 Stand-Alone Traffic Engineering Lighting Plans

Stand-alone lighting projects are advertised and constructed separately from a complete roadway construction project. They may also be developed as part of an area improvement project. Once the scope of the project is understood, developing the project's survey will typically be the lighting designer's first task. Refer to [TEDM Section V – Roadway Lighting, Chapter 4, 4.8.4](#) for a discussion on survey and alignment procedures commonly used in roadway lighting plans.

The roadway lighting plan set is assembled with the following components:

- **Title Sheet.** The title sheet for stand-alone lighting plans must meet all the requirements of a standard VDOT title sheet (refer to the [TEDM Section 1 – General, Chapter 3, 3.4](#)) with the following exceptions:
 - Stand-alone lighting projects do not typically include acquisition of right of way. The Right of Way Signature blocks may not be needed and can be removed from the Title Sheet.
 - The Index of Sheets is typically a short list. This list should be added to the upper-left corner of the Title Sheet.
- **Location Map.**

- **Plan Sheet Index.** The Plan Sheet Index provides an overview of all the plan sheets in the project. It allows quick reference to a particular area of the project. On most roadway lighting projects, the plan sheet index can be incorporated on to the Title Sheet. However, large projects may require a separate Plan Sheet Index for clarity. Refer to [Appendix VA-1](#) for an example of this index.
- **Revision Data Sheet.** This sheet is included with the final plan set, but is left blank with the exception of the project numbers and sheet number, as discussed in the IIM.
- **Alignment Data Sheets, Survey Alignment Coordinate Data Sheets, and Benchmarks.**
- **Maintenance of Traffic.** Occasionally, the maintenance of traffic may be simple, and can be included in the contract documents. Other projects may require a plan sheet to describe the lane closure times and other Work Area Protection items.
- **Roadside Development Sheet.** When required, and as directed by the project manager.
- **Plan Sheets.** Sheet numbers begin at “3”. Details related to a particular plan sheet should be labeled “3A” as shown in [Appendix VA-5 & VA-6](#).

4.11.3 Lighting Plans Incorporated into a Complete Set of Roadway Construction Plans

On large roadway construction projects, the **Title Sheet**, **Revision Data Sheet**, **Roadside Development Sheet**, and **Maintenance of Traffic Sheet** are not required as part of the lighting plan set. The **Location Map** may be added at the discretion of the TE/L&D Manager or the lighting designer.

The roadway lighting plan set is assembled with the following components:

- **Plan Sheet Index.** On roadway construction projects, the roadway lighting plans will typically follow the roadway construction plan sheet numbering. However, in some cases, the roadway lighting portion of the construction project may not require every roadway construction plan sheet. In this case, the roadway lighting plan sheets may be renumbered. The Plan Sheet Index will then provide a reference to the overall construction project.
- **Plan Sheets.** The plan sheet scale should match the roadway construction plans.
- **Plan Sheet Number Series** will be obtained from the construction TE/L&D Manager.