

PREFACE

Chapter 2H has been developed to provide a sample of the various sheets in the plan assembly. These samples are not all inclusive. They are provided to give the Engineer/Designer some insight as to what the basic sheets should encompass. Not all of these samples will be used in all sets of plans. For example, on small projects the Pavement, Incidental and Drainage summaries could be on the same sheet.

List of Figures

Figure 2H-1 Sample Title Sheet.....	2H-1
Figure 2H-2 Sample Title Sheet.....	2H-2
Figure 2H-3 Sample Location Map Sheet.....	2H-3
Figure 2H-4 Sample Index of Sheets.....	2H-4
Figure 2H-5 Sample Right of Way Data Sheet.....	2H-5
Figure 2H-6 Sample Revision Data Sheet.....	2H-6
Figure 2H-7 Sample Stream Flow Hydrograph Sheet.....	2H-7
Figure 2H-8 Sample Survey Alignment Data Sheet.....	2H-8
Figure 2H-9 Sample Construction Alignment Data Sheet.....	2H-9
Figure 2H-10 Sample Underground Utility Test Hole Information.....	2H-10
Figure 2H-11 Sample Traffic Maintenance Plan (TMP) Sheet.....	2H-11
Figure 2H-12 Sample Traffic Maintenance Plan (TMP) Sheet.....	2H-12
Figure 2H-13 Sample Traffic Maintenance Plan (TMP) Sheet.....	2H-13
Figure 2H-14 Sample Traffic Maintenance Plan (TMP) Sheet.....	2H-14
Figure 2H-15 Sample General Notes Sheet.....	2H-15
Figure 2H-16 Sample Typical Section Sheet.....	2H-16
Figure 2H-17 Sample Typical Section Sheet.....	2H-17
Figure 2H-18 Sample Drainage Summary Sheet.....	2H-18
Figure 2H-19 Sample Roadside Development Sheet.....	2H-19
Figure 2H-20 Sample Stormwater Pollution Prevention Sheet.....	2H-20
Figure 2H-21 Sample Stormwater Pollution Prevention Sheet.....	2H-21
Figure 2H-22 Sample Stormwater Pollution Prevention Sheet.....	2H-22
Figure 2H-23 Sample Stormwater Management Summary Sheet.....	2H-23
Figure 2H-24 Sample Pavement Summary Sheet.....	2H-24
Figure 2H-25 Sample Grading Diagram and Summary Sheet.....	2H-25
Figure 2H-26 Sample Incidental Summary Sheet.....	2H-26
Figure 2H-27 Sample Roundabout Detail Sheet.....	2H-27
Figure 2H-28 Sample Radial Offset Sheet.....	2H-28
Figure 2H-29 Sample Metes and Bounds Data Sheet.....	2H-29
Figure 2H-30 Sample Diversion Diamond Interchange Detail Sheet.....	2H-30
Figure 2H-31 Sample 1 Plan Sheet.....	2H-31
Figure 2H-32 Sample 2 Plan Sheet.....	2H-32

Figure 2H-33 Sample 3 Plan Sheet.....	2H-33
Figure 2H-34 Sample 4 Plan Sheet.....	2H-34
Figure 2H-35 Sample 1 Profile Sheet.....	2H-35
Figure 2H-36 Sample 2 Profile Sheet.....	2H-36
Figure 2H-37 Sample 3 Profile Sheet.....	2H-37
Figure 2H-38 Sample Drainage Description Sheet.....	2H-38
Figure 2H-39 Sample Right Of Way Plan Sheet.....	2H-39
Figure 2h-40 Sample Entrance Profile Sheet.....	2H-40

9/16/2014
4:02:42 PM

Title Sheet.dgn
Plotted By: stewartwills

FOR INDEX OF SHEETS SEE SHEET ----

THIS PROJECT WAS DEVELOPED UTILIZING THE DEPARTMENT'S ENGINEERING DESIGN PACKAGE (GEOPAK).
GEOPAK Computer Identification No. (UPC number)



COMMONWEALTH OF VIRGINIA
DEPARTMENT OF TRANSPORTATION

PLAN AND PROFILE OF PROPOSED
STATE HIGHWAY

----- COUNTY/CITY
FROM: RTE. XXX
TO: 0.00 Mi. N. OF RTE. XXX
PROJ. XXXX-XXX-XXX, PE-10X, RW-20X, C-50X

FHWA XXX DATA XXXXX

STATE	FEDERAL AID PROJECT	ROUTE	STATE PROJECT	SHEET NO.
VA.		XXX	(INFO) XXXX-XXX-XXX (SEE TABULATION BELOW FOR SECTION NUMBERS)	1

FUNCTIONAL CLASSIFICATION AND TRAFFIC DATA	
NHS-RURAL COLLECTOR - ROLLING - 30 MPH MIN. DESIGN SPEED	
ADT 2XXX	XXX
ADT	XXX
DHV	XXX
D (%) (design hour)	XXX
T (%) (design hour)	XXX
V (MPH)	X
DESIGN VEHICLE	XXXXX

*SEE PLAN AND PROFILE SHEETS FOR HORIZONTAL AND VERTICAL CURVE DESIGN SPEEDS.
NOTE: THESE PLANS WERE DESIGNED IN ACCORDANCE WITH VIRGINIA RRR GUIDELINES.

THESE PLANS ARE UNFINISHED AND UNAPPROVED AND ARE NOT TO BE USED FOR ANY TYPE OF CONSTRUCTION OR THE ACQUISITION OF RIGHT OF WAY.

ADDITIONAL EASEMENTS FOR UTILITY RELOCATIONS MAY BE REQUIRED BEYOND THE PROPOSED RIGHT-OF-WAY SHOWN ON THESE PLANS.

PROJECT MANAGER <Project_Mgr_Name (000)000-0000 (District)>
SURVEYED BY <Surveyor_Name (000)000-0000 (District)>
DESIGN SUPERVISED BY <Supervisor_Name (000)000-0000 (District)>
DESIGNED BY <Designer_Name (000)000-0000 (District)>

- CONVENTIONAL SIGNS
- STATE LINE
 - COUNTY LINE
 - CITY/TOWN OR VILLAGE
 - RIGHT OF WAY LINE
 - FENCE LINE
 - UNFENCED PROPERTY LINE
 - FENCED PROPERTY LINE
 - WATER LINE
 - SANITARY SEWER LINE
 - GAS LINE
 - ELECTRIC UNDERGROUND CABLE
 - TRAVELED WAY
 - GUARD RAIL
 - RETAINING WALL
 - RAILROADS
 - BASE OR SURVEY LINE
- LEVEE OR EMBANKMENT
 - BRIDGES
 - CULVERTS
 - DROP INLET
 - POWER POLES
 - TELEPHONE OR TELEGRAPH POLES
 - TELEPHONE OR TELEGRAPH LINES
 - HEDGE
 - TREES
 - HEAVY WOODS
 - GROUND ELEVATION
 - GRADE ELEVATION

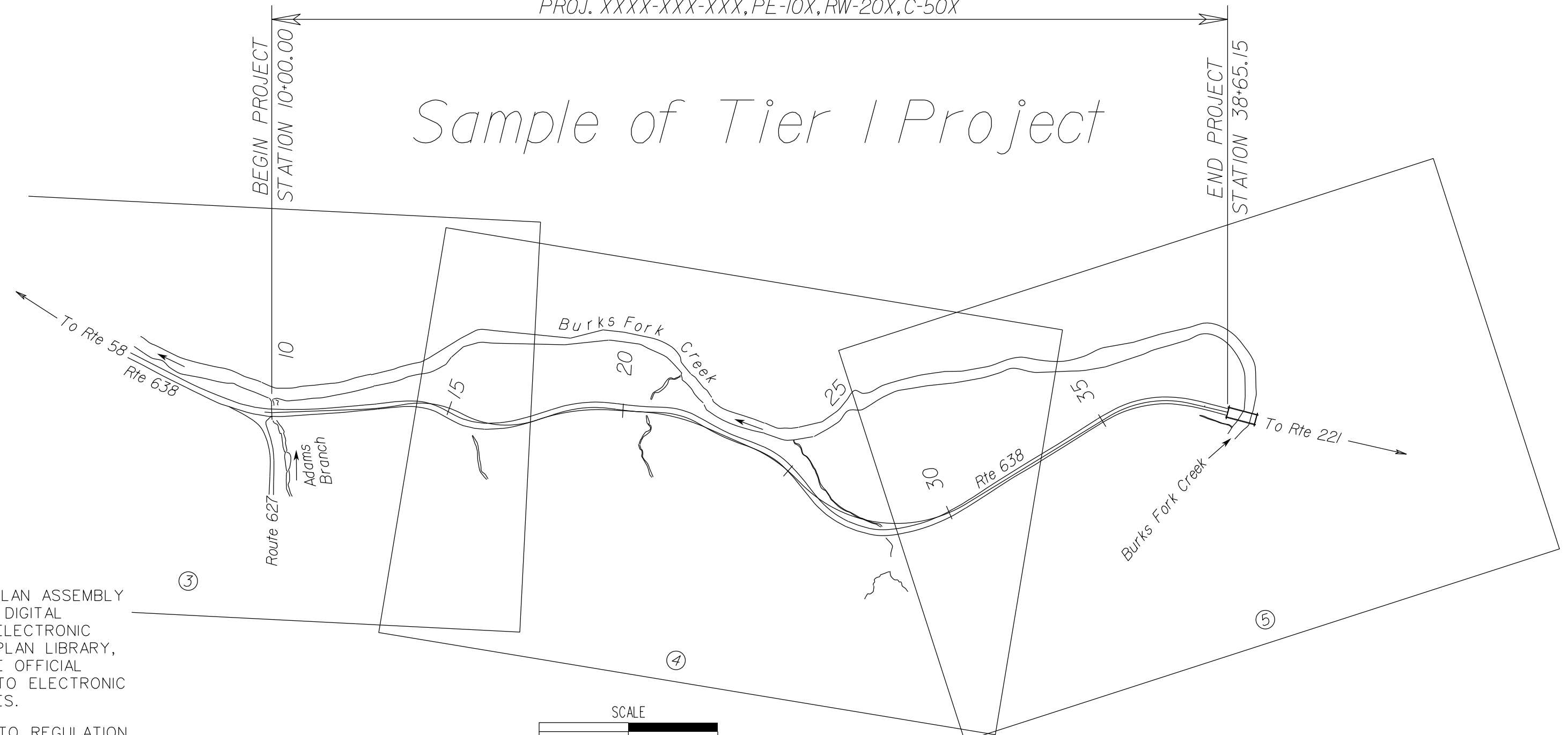

Sample of Tier 1 Project

TIER 1 PROJECT
NOTE: SEE IIM-LD-204 FOR SIGNATURE BLOCK INFORMATION

REVISED

THE COMPLETE ELECTRONIC PDF VERSION OF THE PLAN ASSEMBLY AS AWARDED, HAS BEEN SEALED AND SIGNED USING DIGITAL SIGNATURES AND THE OFFICIAL PLAN ASSEMBLY IN ELECTRONIC FORMAT IS STORED IN THE VDOT CENTRAL OFFICE PLAN LIBRARY. INCLUDING ALL SUBSEQUENT REVISIONS, WILL BE THE OFFICIAL CONSTRUCTION PLANS. FOR INFORMATION RELATIVE TO ELECTRONIC FILES AND LAYERED PLANS, SEE THE GENERAL NOTES.

DESIGN FEATURES RELATING TO CONSTRUCTION OR TO REGULATION AND CONTROL OF TRAFFIC MAY BE SUBJECT TO CHANGE AS DEEMED NECESSARY BY THE DEPARTMENT.

THIS PROJECT IS TO BE CONSTRUCTED IN ACCORDANCE WITH THE DEPARTMENT'S 2007 ROAD AND BRIDGE SPECIFICATIONS, 2008 ROAD AND BRIDGE STANDARDS, 2005 WORK AREA PROTECTION MANUAL AND AS AMENDED BY CONTRACT PROVISIONS AND THE COMPLETE ELECTRONIC .PDF VERSION OF THE PLAN ASSEMBLY.

ALL CURVES ARE TO BE SUPERELEVATED, TRANSITIONED AND WIDENED IN ACCORDANCE WITH STANDARD , EXCEPT WHERE OTHERWISE NOTED.

THE ORIGINAL APPROVED TITLE SHEET(S), INCLUDING ORIGINAL SIGNATURES, ARE FILED IN THE VDOT CENTRAL OFFICE PLAN LIBRARY. ANY MISUSE OF ELECTRONIC FILES, INCLUDING SCANNED SIGNATURES, IS ILLEGAL AND ENFORCED TO THE FULL EXTENT OF THE LAW.

STATE PROJECT NO.	SECTION	FEDERAL AID PROJECT NO.	TYPE CODE	UPC NO.	LENGTH INCLUDING BRIDGE(S)		LENGTH EXCLUDING BRIDGE(S)		BRIDGE PROJECT NO.	TYPE PROJECT	DESCRIPTION
					FEET	MILES	FEET	MILES			
XXXX-XXX-XXX	C-50X		XXXX	XXXXXX	XXXX.XX	X.XX Mi.	XXXX.XX	X.XX Mi.		CONSTRUCTION	FROM: RTE. XXX TO: X.XXMI. N. OF RTE. XXX
	RW-20X		XXXX	XXXXXX	XXXX.XX	X.XX Mi.	XXXX.XX	X.XX Mi.		R/W	FROM: RTE. XXX TO: X.XXMI. N. OF RTE. XXX
	PE-10X		XXXX	XXXXXX	XXXX.XX	X.XX Mi.	XXXX.XX	X.XX Mi.		PREL. ENGR.	FROM: RTE. XXX TO: X.XXMI. N. OF RTE. XXX

NOTE: LENGTH OF PROJECT BASED ON CONSTRUCTION BASELINE

Copyright 20 , Commonwealth of Virginia

PROJECT	SHEET NO.
0638-017-356	1

FIGURE 2H - 1 SAMPLE TITLE SHEET

7/30/2014
8:55:02 AM

Title Sheet.dgn
Plotted By: stewart.wills

FOR INDEX OF SHEETS SEE SHEET ---

THIS PROJECT WAS DEVELOPED UTILIZING THE DEPARTMENT'S ENGINEERING DESIGN PACKAGE (GEOPAK).
GEOPAK Computer Identification No. UPC Number

THESE PLANS ARE UNFINISHED AND UNAPPROVED AND ARE NOT TO BE USED FOR ANY TYPE OF CONSTRUCTION OR THE ACQUISITION OF RIGHT OF WAY.

ADDITIONAL EASEMENTS FOR UTILITY RELOCATIONS MAY BE REQUIRED BEYOND THE PROPOSED RIGHT-OF-WAY SHOWN ON THESE PLANS.



COMMONWEALTH OF VIRGINIA
DEPARTMENT OF TRANSPORTATION

PLAN AND PROFILE OF PROPOSED
STATE HIGHWAY

COUNTY/CITY

FROM: 0.000 Mi. SOUTH INT. ROUTE XXX
TO: 0.000 Mi. NORTH INT. ROUTE XXX

FHWA-DATA-XXXXX

LIMITED ACCESS HIGHWAY			
By Resolution of the Commonwealth Transportation Board, dated _____			
STATE	FEDERAL AID PROJECT	ROUTE	STATE PROJECT
VA.	STP-XXX-X(XXX) See Tabulation Below For Section Numbers	X	(FO)XXX-XXX-XXX See Tabulation Below For Section Numbers
			SHEET NO. /

FUNCTIONAL CLASSIFICATION AND TRAFFIC DATA	
NHS-RURAL OTHER PRINCIPAL ARTERIAL-ROLLING-__MPH MIN. DES. SPEED	
	FROM: 0.000 Mi. SOUTH INT. ROUTE XXX TO: 0.000 Mi. NORTH INT. ROUTE XXX
ADT (Year)	XX,XXX
DHV	X,XXX
D (%) (design hour)	XX%
T (%) (design hour)	XX%
V (MPH)	x
DESIGN VEHICLE	XXXXX

*See Plan and Profile sheets for Horizontal and Vertical Curve Design Speed

CONVENTIONAL SIGNS

STATE LINE	-----
COUNTY LINE	-----
CITY/TOWN OR VILLAGE	-----
RIGHT OF WAY LINE	-----
FENCE LINE	-----
UNFENCED PROPERTY LINE	-----
FENCED PROPERTY LINE	-----
WATER LINE	-----
SANITARY SEWER LINE	-----
GAS LINE	-----
ELECTRIC UNDERGROUND CABLE	-----
TRAVELED WAY	-----
GUARD RAIL	-----
RETAINING WALL	-----
RAILROADS	-----
BASE OR SURVEY LINE	-----

LEVEE OR EMBANKMENT	-----
BRIDGES	-----
CULVERTS	-----
DROP INLET	-----
POWER POLES	-----
TELEPHONE OR TELEGRAPH POLES	-----
TELEPHONE OR TELEGRAPH LINES	-----
HEDGE	-----
TREES	-----
HEAVY WOODS	-----
GROUND ELEVATION	-----
GRADE ELEVATION	-----

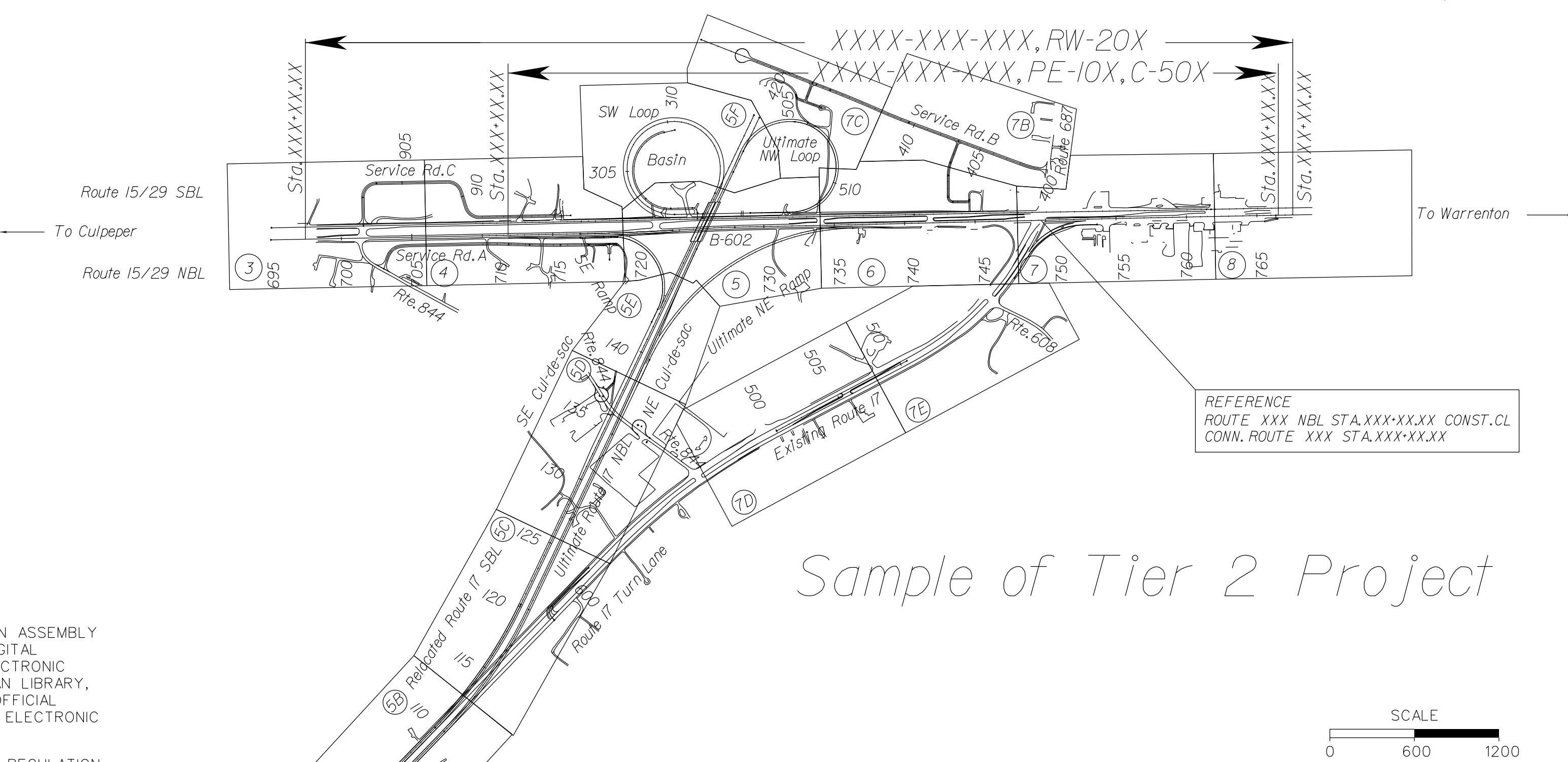

REFERENCE
ROUTE XXX NBL STA. XXX-XX.XX CONST. CL
CONN. ROUTE XXX STA. XXX-XX.XX

Sample of Tier 2 Project

TIER 2 PROJECT

NOTE: SEE IIM-LD-204 FOR SIGNATURE BLOCK INFORMATION

THE COMPLETE ELECTRONIC PDF VERSION OF THE PLAN ASSEMBLY AS AWARDED, HAS BEEN SEALED AND SIGNED USING DIGITAL SIGNATURES AND THE OFFICIAL PLAN ASSEMBLY IN ELECTRONIC FORMAT IS STORED IN THE VDOT CENTRAL OFFICE PLAN LIBRARY, INCLUDING ALL SUBSEQUENT REVISIONS, WILL BE THE OFFICIAL CONSTRUCTION PLANS. FOR INFORMATION RELATIVE TO ELECTRONIC FILES AND LAYERED PLANS, SEE THE GENERAL NOTES.

DESIGN FEATURES RELATING TO CONSTRUCTION OR TO REGULATION AND CONTROL OF TRAFFIC MAY BE SUBJECT TO CHANGE AS DEEMED NECESSARY BY THE DEPARTMENT.

THIS PROJECT IS TO BE CONSTRUCTED IN ACCORDANCE WITH THE DEPARTMENT'S 2007 ROAD AND BRIDGE SPECIFICATIONS, 2008 ROAD AND BRIDGE STANDARDS, 2005 WORK AREA PROTECTION MANUAL AND AS AMENDED BY CONTRACT PROVISIONS AND THE COMPLETE ELECTRONIC .PDF VERSION OF THE PLAN ASSEMBLY.

ALL CURVES ARE TO BE SUPERELEVATED, TRANSITIONED AND WIDENED IN ACCORDANCE WITH STANDARD _____, EXCEPT WHERE OTHERWISE NOTED.

THE ORIGINAL APPROVED TITLE SHEET(S), INCLUDING ORIGINAL SIGNATURES, ARE FILED IN THE VDOT CENTRAL OFFICE PLAN LIBRARY. ANY MISUSE OF ELECTRONIC FILES, INCLUDING SCANNED SIGNATURES, IS ILLEGAL AND ENFORCED TO THE FULL EXTENT OF THE LAW.

Population _____ County XX,XXX (2010 Census)

STATE PROJECT NO.	SECTION	FEDERAL AID PROJECT NO.	TYPE CODE	UPC NO.	LENGTH INCLUDING BRIDGE(S)		LENGTH EXCLUDING BRIDGE(S)		BRIDGE PLAN NO.	TYPE PROJECT	DESCRIPTION
					FEET	MILES	FEET	MILES			
XXXX-XXX-XXX	C-50X	NH/STP-XXX-X()	XXXX	XXXXXX	XXXX.XX	X.XXX	XXXX.XX	X.XXX		CONST.	From: X.XXX Mi. S. Int. Route XXX To: X.XXX Mi. N. Int. Route XXX
	PE-10X	STP-XXX-X(XXX)		XXXXXX	XXXX.XX	X.XXX	XXXX.XX	X.XXX		PREL. ENGR.	From: X.XXX Mi. S. Int. Route XXX To: X.XXX Mi. N. Int. Route XXX
	RW-20X	STP-XXX-X(XXX)		XXXXXX	XXXX.XX	X.XXX	XXXX.XX	X.XXX		R/W	From: X.XXX Mi. S. Int. Route XXX To: X.XXX Mi. N. Int. Route XXX
	B-60X	NH/STP-XXX-X()	X000-SN	XXXXXX	XXX.XXX	X.XXX				BRIDGE	Rte. XXX Bridge over XXXXXX
	D-60X	NH/STP-XXX-X()		XXXXXX	XXX.XXX	X.XXX				PREL. ENGR.	Rte. XXX Bridge over XXXXXX

REVISED

PROJECT LENGTH BASED ON RTE. XXX NBL CONSTRUCTION BASELINE.

PLAN NO.	PROJECT	FILE NO.	SHEET NO.
	XXXX-XXX-XXX		/

FIGURE 2H - 2 SAMPLE TITLE SHEET

9/9/2014
8:41:09 AM

Project Location Map.dgn
Plotted By: stewartwills

PROJECT MANAGER _____
SURVEYED BY, DATE _____
DESIGN BY _____
SUBSURFACE UTILITY BY, DATE _____

DESIGN FEATURES RELATING TO CONSTRUCTION
OR TO REGULATION AND CONTROL OF TRAFFIC
MAY BE SUBJECT TO CHANGE AS DEEMED
NECESSARY BY THE DEPARTMENT

REVISED	STATE	FEDERAL AID PROJECT	ROUTE	STATE PROJECT	SHEET NO.
	VA.		XXX	XXXX-XXX-XXX,C-XXX	1A

LOCATION MAP

----- COUNTY

PROPOSED PROJECT
XXXX-XXX-XXX, C-XXX

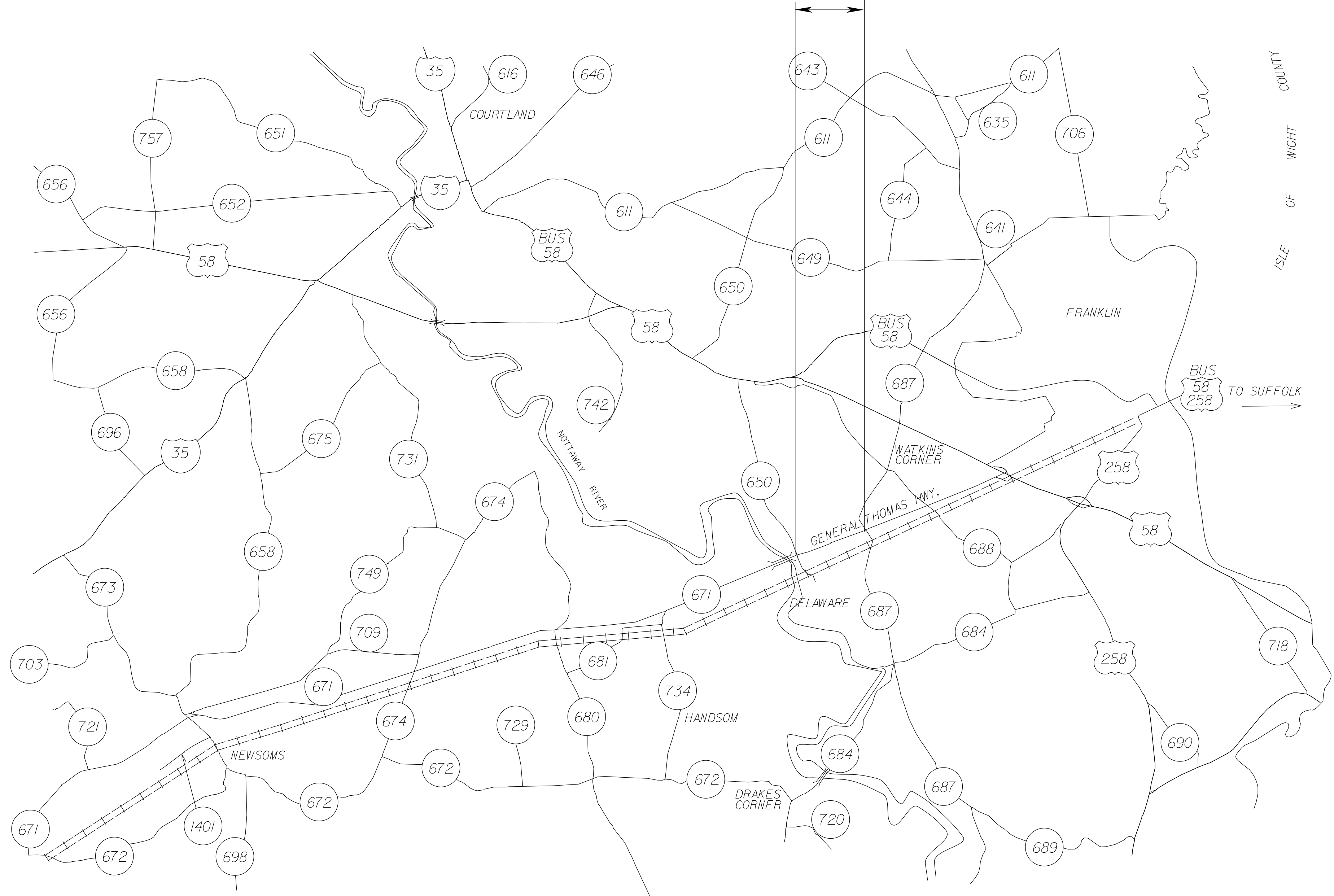

COUNTY OF -----
POPULATION XX,XXX
(YEAR) CENSUS

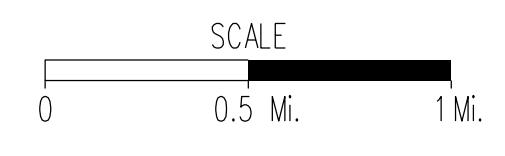

PLAN NO.	PROJECT	FILE NO.	SHEET NO.
	XXXX-XXX-XXX		1A

FIGURE 2H - 3 SAMPLE LOCATION MAP SHEET

7/30/2014
9:32:16 AM

Indexof sheets.dgn
Plotted By: stewartwillis

PROJECT MANAGER <Project_Mgr_Name.(000) 000-0000 (District)>
SURVEYED BY <Surveyor_Name.(000) 000-0000 (District)>
DESIGN SUPERVISED BY <Supervisor_Name.(000) 000-0000 (District)>
DESIGNED BY <Designer_Name.(000) 000-0000 (District)>

INDEX OF SHEETS

REVISED	STATE	STATE		SHEET NO.
		ROUTE	PROJECT	
	VA.	00	0000-000-000, RW-000 C-000	0

SHEET	DESCRIPTION	STATIONS
1	Title Sheet	
1A	Location Map	
1B	Index of Sheets	
1C	Right of Way Data Sheet	
1D	Revision Data Sheet	
1E	Stream Flow Hydrograph Sheet	
1F-1G	Survey and Construction Alignment Data Sheets	
1H	Underground Utility Test Hole Information Sheet	
1J(1)- 1J(18)	Maintenance of Traffic / Sequence of Construction Sheets	
2	General Notes	
2A - 2E	Typical Sections	
2F - 2J	Drainage Summary	
2K	Roadside Development / Erosion Control Summary	
2L	Box Culvert Summary, Stormwater Management Summary	
2M	Pavement Summary	
2N	Grading Diagram and Summary	
2O	Incidental Summary	
2P - 2AAA	Detail Sheets	
3 - 3B	Plan, Profile and Drainage Descriptions	643+14.15 to 644+20.00
3C	Phased Erosion and Sediment Control Plan	
3RW	Right of Way Plan Sheet	
4 - 4G	Plan, Profile and Drainage Descriptions	644+20.00 to 646+20.00
4H	Phased Erosion and Sediment Control Plan	
4RW	Right of Way Plan Sheet	
5 - 5C	Plan, Profile and Drainage Descriptions	646+20.00 to 648+20.00
5D	Phased Erosion and Sediment Control Plan	
5RW	Right of Way Plan Sheet	
6 - 6C	Plan, Profile and Drainage Descriptions	648+20.00 to 650+20.00
6D	Phased Erosion and Sediment Control Plan	
6RW	Right of Way Plan Sheet	
7 - 7B	Plan and Profile	650+20.00 to 652+20.00
7C	Phased Erosion and Sediment Control Plan	
7RW	Right of Way Plan Sheet	
8 - 8B	Plan, Profile and Drainage Descriptions	652+20.00 to 654+20.00
8C	Phased Erosion and Sediment Control Plan	
8RW	Right of Way Plan Sheet	
9 - 9A	Plan and Profile	654+20.00 to 656+20.00
9B	Phased Erosion and Sediment Control Plan	
9RW	Right of Way Plan Sheet	
10 - 10B	Plan, Profile and Drainage Descriptions	656+20.00 to 658+20.00
10C	Phased Erosion and Sediment Control Plan	
10RW	Right of Way Plan Sheet	
11(1) - 11(4)	Entrance Profiles	
12(1) - 12(8)	Storm Sewer Profile Sheets	
13(1) - 13(8)	Sign Plans	
14(1) - 14(8)	Lighting Plans	
15(1) - 15(8)	Signal Plans	
16(1) - 16(8)	Pavement Marking and Marker Plans	
17(1) - 17(8)	Utility Plans	
18(1) - 18(8)	Landscape Plans	

Total Cross Section Sheets 49 (See cross section sheet number 1 for Index of Cross Sections)

Special Design Bridge Plans Sheets, B-601, Plan No. 19 (1) - 19 (20), Rte. 143 Over Little Creek

PROJECT	SHEET NO.
0000-000-000	0

FIGURE 2H - 4 SAMPLE INDEX OF SHEET

8/29/2014
2:28:46 PM

Right of Way Data Sheet.dgn
Plotted By:stewartwillis

PROJECT MANAGER _____
SURVEYED BY, DATE _____
DESIGN BY _____
SUBSURFACE UTILITY BY, DATE _____

PRELIMINARY RIGHT OF WAY DATA SHEET

DESIGN FEATURES RELATING TO CONSTRUCTION
OR TO REGULATION AND CONTROL OF TRAFFIC
MAY BE SUBJECT TO CHANGE AS DEEMED
NECESSARY BY THE DEPARTMENT

REVISED	STATE	FEDERAL AID PROJECT	ROUTE	STATE PROJECT	SHEET NO.
	VA.			XXXX-XXX-XXX, RW-20X C-50X	IC

ROUTE:	PROJECT:
COUNTY/CITY:	PPMS NO. :
COMPILED BY:	DATE:
REVISIONS BY:	DATE:

PARCEL NO.	LANDOWNER	SHEET NO.	Areas greater than or equal to 1 acre will be shown in acres to 3 decimal places (x.xxx). Areas less than 1 acre will be shown to square feet (x,xxx).																		
			TOTAL	FEE TAKING		PRESCRIPTIVE R/W		FEE REMAINDER		EASEMENTS						PROFFERS					
				ACRES OR SQUARE FEET	ACRES OR SQ. FEET	HECTARES/ OR SQ. METERS	ACRES OR SQ. FEET	HECTARES/ OR SQ. METERS	ACRES OR SQ. FEET	HECTARES/ OR SQ. METERS	PERMANENT		UTILITY		TEMPORARY		TEMPORARY (ENTRANCES)				
										ACRES OR SQ. FEET	HECTARES/ OR SQ. METERS	ACRES OR SQ. FEET	HECTARES/ OR SQ. METERS	ACRES OR SQ. FEET	HECTARES/ OR SQ. METERS	ACRES OR SQ. FEET	HECTARES/ OR SQ. METERS	ACRES OR SQ. FEET	HECTARES/ OR SQ. METERS	YES / NO	

PLAN NO.	PROJECT XXXX-XXX-XXX	FILE NO.	SHEET NO. IC
----------	-------------------------	----------	-----------------

FIGURE 2H - 5 SAMPLE RIGHT OF WAY DATA SHEET

9/5/2014
1:07:54 PM

Stream Flow Hydrograph Sheet.dgn
Plotted By: stewartwills

PROJECT MANAGER <Project_Mgr_Name (000) 000-0000 (District)> -----
SURVEYED BY, DATE <Surveyor_Name (000) 000-0000 (District)> -----
DESIGN BY <Designer_Name (000) 000-0000 (District)> -----
SUBSURFACE UTILITY BY, DATE <Surveyor_Name (000) 000-0000 (District)> -----

REVISED	STATE	ROUTE	STATE PROJECT	SHEET NO.
	VA.		XXXX-XXX-XXX, RW-20X C-50X	

DESIGN FEATURES RELATING TO CONSTRUCTION OR TO REGULATION AND CONTROL OF TRAFFIC MAY BE SUBJECT TO CHANGE AS DEEMED NECESSARY BY THE DEPARTMENT

HYDROLOGIC DATA

The data presented herein was statistically derived by empirical methods and from field observations. It is presented as an estimate of the hydraulic performance of these facilities during the passage of actual flood events.

1. Estimated 100 year frequency flood data (unless otherwise noted.) This magnitude of flooding may pass through the proposed facility or it may obtain the necessary hydraulic conveyance by partial inundation of roadways and/or partial by pass of the facility.

2. Specified frequency flood data. It is anticipated that this magnitude of flooding will be conveyed through the proposed hydraulic facility under estimated conditions which satisfy the design criteria applicable to the site.

3. This data was obtained from observations by persons familiar with the area and/or official records combined with an evaluation by empirical methods. The reliability of this data is relative to the accuracy of the source. A future flood of the same magnitude may achieve a significantly different stage elevation from that shown due to changes in the physical characteristics of the watershed.

FIELD INSPECTION STAGE <input type="checkbox"/>		FINAL DESIGN STAGE <input type="checkbox"/>			BASE FLOOD 1.		DESIGN FLOOD 2.			OVERTOPPING FLOOD		HISTORICAL DATA 3.		
Sheet No.	Station	Stream Name	Drainage Area	Structure Size	Discharge (C.F.S.)	Stage Elevation (Ft.)	Discharge (C.F.S.)	Estimated Exceedance Probability %	Stage Elevation (Ft.)	Stage Elevation (Ft.)	Estimated Exceedance Probability %	Date	Stage Elevation (Ft.)	Estimated Exceedance Probability %
REMARKS Source of Information and Other Related Data														

	PROJECT XXXX-XXX-XXX	SHEET NO. 1E
--	-------------------------	-----------------

FIGURE 2H - 7 SAMPLE STREAM FLOW HYDROGRAPH SHEET

6/14/2014
2:03:39 PM

Survey & Constr Alignment Data Sheets.dgn
Plotted By: stewartwills

PROJECT MANAGER _____
SURVEYED BY, DATE _____
DESIGN BY _____
SUBSURFACE UTILITY BY, DATE _____

Note: To Convert VA State Plane Coordinates NAD 83 Metric Values to VDOT Project Coordinates:
1. Reduce the Easting 2.5 Million Meters, and the South and North Zone Northing by 1 and 2 Million Respectively.
2. Multiply by the US Survey Foot (3,280,833.3333).
3. Multiply These Values by the Combined Scale and Elevation Factor (1.00005) for this County.
A Reverse of This Procedure will Transform VDOT Project Coordinates to NAD 83 Values.

DESIGN FEATURES RELATING TO CONSTRUCTION OR TO REGULATION AND CONTROL OF TRAFFIC MAY BE SUBJECT TO CHANGE AS DEEMED NECESSARY BY THE DEPARTMENT

REVISED	STATE	ROUTE	STATE PROJECT	SHEET NO.
	VA.	XXX	XXXX-XXX-XXX, C-50X R-XXX	IF

LD-200 (REV. 6/2000)

Virginia Department of Transportation Horizontal Control

Control Station I. D. 36 - 0053 Project 0615-036-156.P101.R201.C501 **VDOT Project Coordinates**

Route 615 City/County Gloucester Date Nov. 2011 East (X) 3844816.2142 ft.

Established By VDOT North (Y) 392927.3104 ft.

Vertical Datum Based On NAVD 88 Geoid 2009 Elevation 79.80 ft.

Horizontal Datum Based On NAD 83 (2007) Zone North **South** (circle one)

Azimuth to Station 36-0054 ~ 66°16'09"

Latitude: 37°23'47.62968" N (5 Decimal Places) To convert state plane metric units to VDOT project values, use the following formula.

Longitude: 76°33'32.60557" W (5 Decimal Places)

Geoid Separation (N) ~ -35.292m

Ellipsoid Height (H) ~ -10.969m (WGS 84)

Control Based On: Station "040" (PID #GV9550) Horizontal "H 457" (PID #GV0579) Vertical

1. Reduce the Easting Metric Values By 2.5 Million Meters. The South and North Zone Northing Metric Values By 1 and 2 Million Respectively.
2. Multiply These Values by the U. S. Survey Foot (3.280833333)
3. Multiply These Values by Combined Scale and Elevation Factor (1.00005) for the County.

Reverse This Procedure to Transform VDOT Project Coordinates to NAD 83 Metric Plane Coordinates

Virginia State Plane Coordinates - NAD 83 Metric Values

East (X) 3571843.7337 m
North (Y) 1119758.4988 m
Ortho. Elevation (H) 24.323 m

• Sketch and Detailed Description Below •

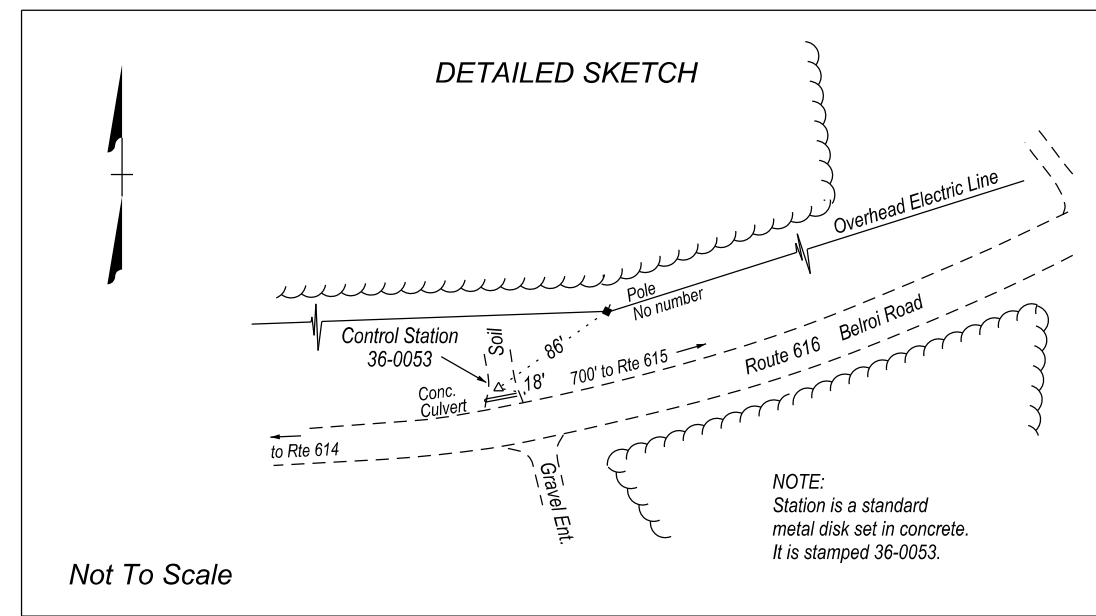

LD-200 (REV. 6/2000)

Virginia Department of Transportation Horizontal Control

Control Station I. D. 36 - 0054 Project 0615-036-156.P101.R201.C501 **VDOT Project Coordinates**

Route 615 City/County Gloucester Date Nov. 2011 East (X) 3849195.0093 ft.

Established By VDOT North (Y) 393093.8331 ft.

Vertical Datum Based On NAVD 88 Geoid 2009 Elevation 80.25 ft.

Horizontal Datum Based On NAD 83 (2007) Zone North **South** (circle one)

Azimuth to Station 36-0053 ~ 246°16'09"

Latitude: 37°23'49.19899" N (5 Decimal Places) To convert state plane metric units to VDOT project values, use the following formula.

Longitude: 76°33'27.87004" W (5 Decimal Places)

Geoid Separation (N) ~ -35.294m

Ellipsoid Height (H) ~ -10.834m (WGS 84)

Control Based On: Station "040" (PID #GV9550) Horizontal "H 457" (PID #GV0579) Vertical

1. Reduce the Easting Metric Values By 2.5 Million Meters. The South and North Zone Northing Metric Values By 1 and 2 Million Respectively.
2. Multiply These Values by the U. S. Survey Foot (3.280833333)
3. Multiply These Values by Combined Scale and Elevation Factor (1.00005) for the County.

Reverse This Procedure to Transform VDOT Project Coordinates to NAD 83 Metric Plane Coordinates

Virginia State Plane Coordinates - NAD 83 Metric Values

East (X) 3671959.1849 m
North (Y) 1119809.2495 m
Ortho. Elevation (H) 24.460 m

• Sketch and Detailed Description Below •

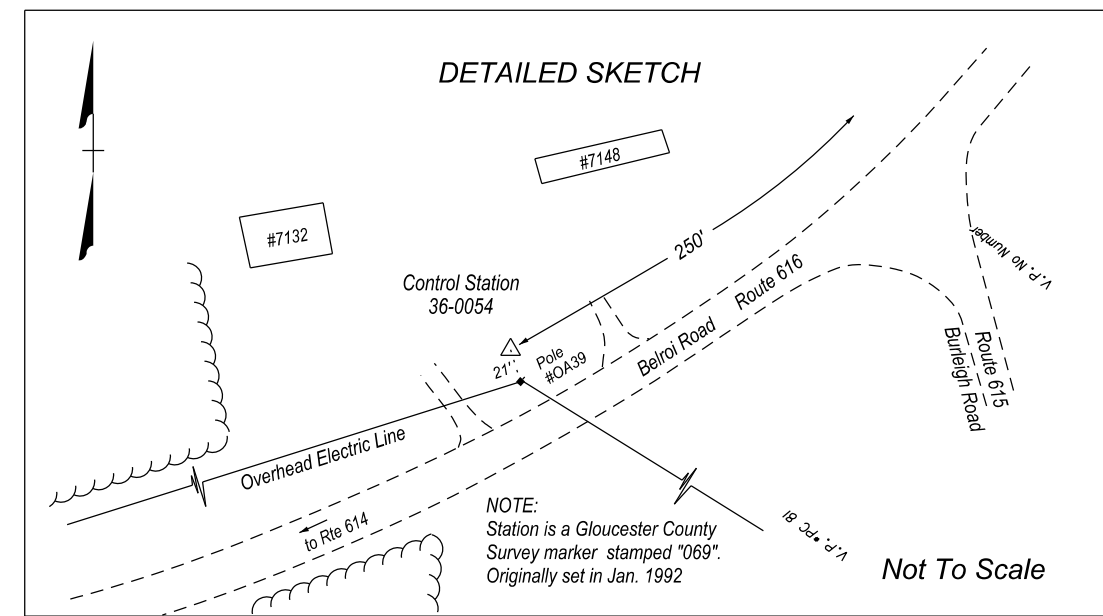

Horizontal Datum NAD 83/07
South Zone

SURVEY ALIGNMENTS

POINT ID.	STATION	BEARING	VDOT PROJECT NORTH (Y)	COORDINATES EAST (X)
	Rte 615 Traverse			
SS	10+00.000		393,179.482	3,845,448.908
PI	15+52.195	S 17° 30' 55" E	392,652.888	3,845,615.096
PI	20+50.100	S 56° 05' 52" E	392,375.168	3,846,028.353
PI	24+59.059	S 62° 02' 09" E	392,183.399	3,846,389.562
PI	30+75.058	S 55° 11' 54" E	391,831.826	3,846,895.379
PI	34+74.772	N 88° 29' 57" E	391,842.295	3,847,294.956
PI	38+67.181	S 35° 39' 04" E	391,523.431	3,847,523.671
PI	43+19.003	S 55° 52' 46" E	391,269.987	3,847,897.716
PI	47+45.936	S 42° 39' 14" E	390,955.995	3,848,186.992
PI	51+19.651	S 64° 52' 16" E	390,797.295	3,848,525.337
PI	55+15.198	S 57° 29' 37" E	390,566.491	3,848,846.564
PI	62+47.970	S 61° 52' 15" E	390,172.704	3,849,464.534
PI	68+83.614	S 14° 20' 42" E	389,873.023	3,850,025.100
PI	72+79.229	S 44° 17' 12" E	389,489.742	3,850,123.117
PI	78+23.949	S 44° 17' 12" E	389,099.802	3,850,503.467
PI	84+12.608	N 88° 23' 37" E	389,116.304	3,851,091.895
PI	89+90.685	S 68° 38' 43" E	388,905.802	3,851,630.283
PI	95+96.591	S 83° 09' 51" E	388,833.684	3,852,231.882

LD-200 (REV. 6/2000)

Virginia Department of Transportation Horizontal Control

Control Station I. D. 36 - 0055 Project 0615-036-156.P101.R201.C501 **VDOT Project Coordinates**

Route 615 City/County Gloucester Date Nov. 2011 East (X) 3852231.8834 ft.

Established By VDOT North (Y) 388833.8854 ft.

Vertical Datum Based On NAVD 88 Geoid 2009 Elevation 78.10 ft.

Horizontal Datum Based On NAD 83 (2007) Zone North **South** (circle one)

Azimuth to Station 36-0056 ~ 358°52'39"

Latitude: 37°23'05.64837" N (5 Decimal Places) To convert state plane metric units to VDOT project values, use the following formula.

Longitude: 76°32'01.78621" W (5 Decimal Places)

Geoid Separation (N) ~ -35.364m

Ellipsoid Height (H) ~ -11.559m (WGS 84)

Control Based On: Station "040" (PID #GV9550) Horizontal "H 457" (PID #GV0579) Vertical

1. Reduce the Easting Metric Values By 2.5 Million Meters. The South and North Zone Northing Metric Values By 1 and 2 Million Respectively.
2. Multiply These Values by the U. S. Survey Foot (3.280833333)
3. Multiply These Values by Combined Scale and Elevation Factor (1.00005) for the County.

Reverse This Procedure to Transform VDOT Project Coordinates to NAD 83 Metric Plane Coordinates

Virginia State Plane Coordinates - NAD 83 Metric Values

East (X) 3574103.9212 m
North (Y) 1118510.8189 m
Ortho. Elevation (H) 23.805 m

• Sketch and Detailed Description Below •

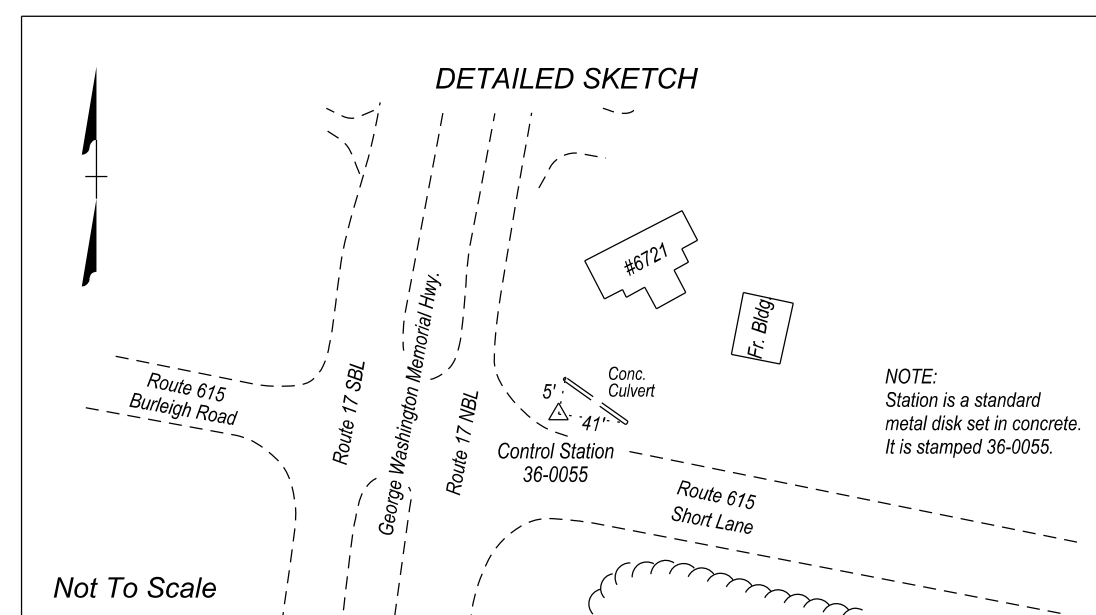

LD-200 (REV. 6/2000)

Virginia Department of Transportation Horizontal Control

Control Station I. D. 36 - 0056 Project 0615-036-156.P101.R201.C501 **VDOT Project Coordinates**

Route 615 City/County Gloucester Date Nov. 2011 East (X) 3852224.5009 ft.

Established By VDOT North (Y) 389210.4523 ft.

Vertical Datum Based On NAVD 88 Geoid 2009 Elevation 79.26 ft.

Horizontal Datum Based On NAD 83 (2007) Zone North **South** (circle one)

Azimuth to Station 36-0055 ~ 178°52'39"

Latitude: 37°23'09.37420" N (5 Decimal Places) To convert state plane metric units to VDOT project values, use the following formula.

Longitude: 76°32'01.78044" W (5 Decimal Places)

Geoid Separation (N) ~ -35.362m

Ellipsoid Height (H) ~ -11.204m (WGS 84)

Control Based On: Station "040" (PID #GV9550) Horizontal "H 457" (PID #GV0579) Vertical

1. Reduce the Easting Metric Values By 2.5 Million Meters. The South and North Zone Northing Metric Values By 1 and 2 Million Respectively.
2. Multiply These Values by the U. S. Survey Foot (3.280833333)
3. Multiply These Values by Combined Scale and Elevation Factor (1.00005) for the County.

Reverse This Procedure to Transform VDOT Project Coordinates to NAD 83 Metric Plane Coordinates

Virginia State Plane Coordinates - NAD 83 Metric Values

East (X) 3674101.6711 m
North (Y) 1118625.6549 m
Ortho. Elevation (H) 24.158 m

• Sketch and Detailed Description Below •

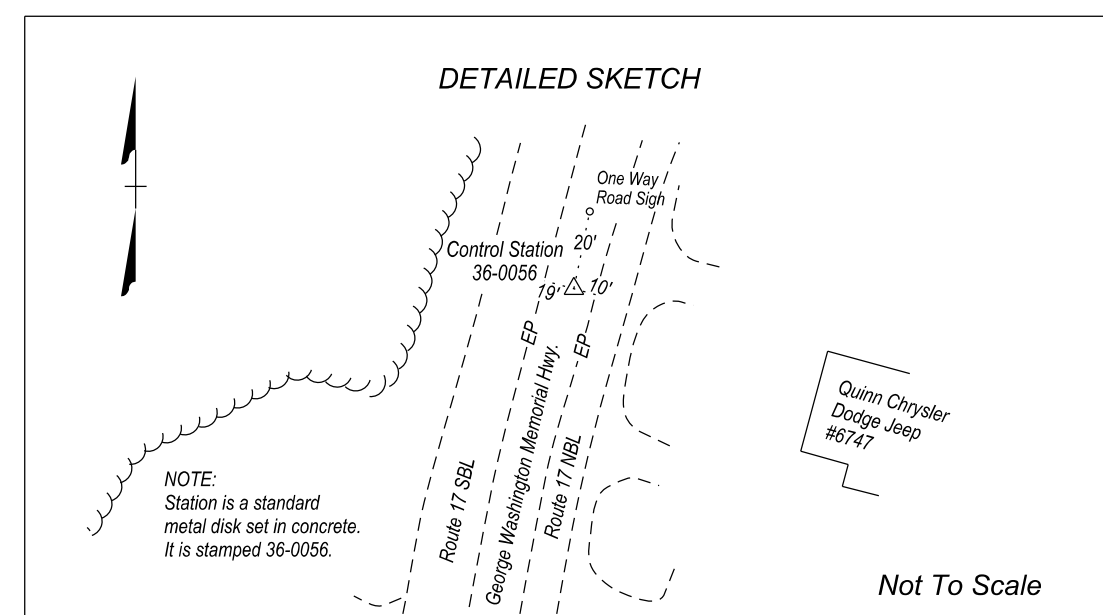

Benchmarks ~ NAVD 88 Datum
Elev. Benchmark Description / Location

79.80'	VDOT Control Station 36-0053
80.25'	VDOT Control Station 36-0054
72.70'	NE corner of first brick step (*5802); 111' Rt. of Sta. 22+33 Rte 615 Traverse
36.40'	RR Spike set in base of 24" Ash; 92' Lt. of Sta. 35+93 Rte 615 Traverse
47.01'	RR Spike set in base of 20" Scyamore; 60' Rt. of Sta. 47+60 Rte 615 Traverse
79.87'	RR Spike set in base of Twin 48" Maple; 89' Lt. of Sta. 57+84 Rte 615 Traverse
79.91'	RR Spike set in base of 12" Beech; 34' Rt. of Sta. 73+10 Rte 615 Traverse
78.82'	SE corner of first brick step (*6433); 91' Rt. of Sta. 85+66 Rte 615 Traverse
78.10'	VDOT Control Station 36-0055
79.26'	VDOT Control Station 36-0056

PROJECT	SHEET NO.
XXXX-XXX-XXX	IF

8/14/2014
3:00:22 PM

Construction Alignment Data Sheets.dgn
Plotted By: stewartwillis

PROJECT MANAGER _____
SURVEYED BY, DATE _____
DESIGN BY _____
SUBSURFACE UTILITY BY, DATE _____

CONSTRUCTION ALIGNMENT

REVISED	STATE	ROUTE	STATE PROJECT	SHEET NO.
	VA.	XXX	XXXX-XXX-XXX, C-50X R-20X	IG
DESIGN FEATURES RELATING TO CONSTRUCTION OR TO REGULATION AND CONTROL OF TRAFFIC MAY BE SUBJECT TO CHANGE AS DEEMED NECESSARY BY THE DEPARTMENT				
Location & Design Fredericksburg, Virginia ROADWAY ENGINEER				

* 1 DESCRIBE CHAIN 79094

Chain 79094 contains:
D001 CUR C41 CUR C42 D006 D007 D010 D011

Beginning chain 79094 description
Feature: Adjusted Alignment
Description: 700'r 485'r

Point D001 N 391,998.64 E 3,846,650.05 Sta 28+00.00

Course from D001 to PC C41 S 57° 12' 38.02" E Dist 219.90

Curve Data

Curve C41
P.I. Station 31+27.64 N 391,821.20 E 3,846,925.48
Delta = 17° 29' 58.00" (LT)
Degree = 8° 11' 06.40"
Tangent = 107.74
Length = 213.80
Radius = 700.00
External = 8.24
Long Chord = 212.97
Mid. Ord. = 8.15
S. E. = 7.200
V = 40
P.C. Station 30+19.90 N 391,879.55 E 3,846,834.91
P.T. Station 32+33.70 N 391,792.79 E 3,847,029.41
C.C. = N 392,468.01 E 3,847,214.00
Back = S 57° 12' 38.02" E
Ahead = S 74° 42' 36.02" E
Chord Bear = S 65° 57' 37.02" E

Course from PT C41 to PC C42 S 74° 42' 36.02" E Dist 193.48

Curve Data

Curve C42
P.I. Station 35+35.62 N 391,713.17 E 3,847,320.64
Delta = 25° 12' 26.24" (RT)
Degree = 11° 48' 48.83"
Tangent = 108.44
Length = 213.38
Radius = 485.00
External = 11.98
Long Chord = 211.66
Mid. Ord. = 11.69
S. E. = 8.000
V = 40
P.C. Station 34+27.18 N 391,741.77 E 3,847,216.04
P.T. Station 36+40.56 N 391,642.75 E 3,847,403.11
C.C. = N 391,273.94 E 3,847,088.14
Back = S 74° 42' 36.02" E
Ahead = S 49° 30' 09.78" E
Chord Bear = S 62° 06' 22.90" E

Course from PT C42 to D006 S 49° 30' 09.78" E Dist 258.73

Point D006 N 391,474.73 E 3,847,599.86 Sta 38+99.29

Course from D006 to D007 S 48° 33' 09.83" E Dist 52.06

Point D007 N 391,440.27 E 3,847,638.88 Sta 39+51.34

Course from D007 to D010 S 54° 47' 55.71" E Dist 263.75

Point D010 N 391,288.23 E 3,847,854.40 Sta 42+15.10

Course from D010 to D011 S 45° 20' 25.86" E Dist 236.89

Point D011 N 391,121.72 E 3,848,022.90 Sta 44+51.99

Ending chain 79094 description

PROJECT	SHEET NO.
XXXX-XXX-XXX	IG

FIGURE 2H - 9 SAMPLE CONSTRUCTION ALIGNMENT DATA SHEET

PROJECT MANAGER _____
 SURVEYED BY _____
 DESIGN SUPERVISED BY _____
 DESIGNED BY _____

UNDERGROUND UTILITIES TEST HOLE INFORMATION

REVISED	STATE	ROUTE	STATE PROJECT	SHEET NO.
	VA.	XX	XXXX-XXX-XXX, RW-20X C-50X	IH

DESIGN FEATURES RELATING TO CONSTRUCTION
 OR TO REGULATION AND CONTROL OF TRAFFIC
 MAY BE SUBJECT TO CHANGE AS DEEMED
 NECESSARY BY THE DEPARTMENT

PLAN SHEET	TEST HOLE	DISTANCE (FEET)	(1) STATION & BASELINE	OWNER	TYPE OF FACILITY	(2) ELEV. (FEET)	(3) CONFLICT YES/NO	(4) REMARKS	UTILITY (5) ADJUSTMENT REQUIRED
3	1	84.9 RT.	56+91.8 ± (a)	A	2.75"± O.D. METALLIC WATER 1"± O.D. METALLIC WATER	205.84 205.90		NO CLEARANCE	
7	2	67.7 RT.	86+55.1 ± (c)	A	13"± O.D. METALLIC WATER	205.61		0.5' CLEARANCE ABOVE STORM DRAIN	
4	3	47.1 LT.	60+07.9 ± (a)	B	TOP OF FOUR 4"± O.D. NON-MET. CONDUITS BOTTOM OF 4"± O.D. NON-MET. CONDUITS	202.73 201.91		0.9' CLEARANCE BELOW STORM DRAIN 1.7' CLEARANCE BELOW STORM DRAIN	
4	4	15.2 LT.	60+57.1 ± (a)	B	TOP OF T/Tg DUCT	203.42		1.75' CLEARANCE BELOW STRUCTURE 4-17 (SEE TH FORM FOR REMARKS)	
4	4A	26.8 LT.	60+56.2 ± (a)	B	TOP OF T/Tg DUCT	204.12		NO STORM DRAIN CROSSING (SEE TH FORM FOR REMARKS)	
4	5	57.5 RT.	59+74.2 ± (a)	B	23.0"± O.D. METALLIC CASING PIPE	201.68		NO STORM DRAIN CROSSING	
4	6	78.5 RT.	59+74.1 ± (a)	B	1"± O.D. CONDUIT TOP OF CONC. CAP 1.5"± O.D. BLACK CABLE	205.22 203.60 200.61		(SEE TEST HOLE FORM FOR REMARKS) NO STORM DRAIN CROSSING	
4	7	83.1 RT.	59+31.8 ± (a)	B	1.5"± O.D. NON-METALLIC CONDUIT	206.20		2.1' CLEARANCE ABOVE STORM DRAIN	
4	8	50.2 RT.	85+79.5 ± (c)	B	TOP OF CONC. CAP BOTTOM OF BOTTOM CONDUIT	201.29 199.88		(SEE TEST HOLE FORM FOR REMARKS) 1.5' CLEARANCE BELOW STORM DRAIN (STORM DRAIN CROSSES UTILITY 27' WEST OF TEST HOLE)	
--	9	--	--	--	CANCELLED BY DEPARTMENT	--			
4	10	81.0 RT.	60+51.0 ± (a)	B	TWO 4"± O.D. NON-METALLIC CONDUITS	201.73		2.6' CLEARANCE BELOW STORM DRAIN	
--	11	--	--	--	CANCELLED BY DEPARTMENT	--			
--	12	--	--	--	CANCELLED BY DEPARTMENT	--			
3	13	82.7 RT.	55+08.2 ± (a)	C	2.5"± O.D. NON-METALLIC GAS	202.44		0.4' CLEARANCE BELOW STORM DRAIN	
5	14	80.1 RT.	64+10.2 ± (a)	C	2.5"± O.D. NON-METALLIC GAS	202.77		2.4' CLEARANCE BELOW MANHOLE	
6	15	28.3 LT.	453+04.0 ± (b)	C	1.5"± O.D. NON-METALLIC GAS	214.94		NO STORM DRAIN CROSSING	
--	16	--	--	--	CANCELLED BY DEPARTMENT	--			
--	17	--	--	--	CANCELLED BY DEPARTMENT	--			
3	18	89.9 RT.	56+46.6 ± (a)	A	6.5"± O.D. METALLIC SANITARY SEWER	206.32		NO CLEARANCE	
--	19	--	--	--	CANCELLED BY DEPARTMENT	--			
--	20	--	--	--	CANCELLED BY DEPARTMENT	--			
4	21	52.2 LT.	60+35.3 ± (a)	A	1"± O.D. METALLIC PIPE 1.25"± O.D. METALLIC PIPE	207.15 206.97		1.6' CLEARANCE ABOVE STORM DRAIN 1.4' CLEARANCE ABOVE STORM DRAIN	
--	22	--	--	--	CANCELLED BY DEPARTMENT	--			
3	23	112.2 RT.	55+11.5 ± (a)	A	12.75"± O.D. METALLIC WATER (SEE NOTE 6) 12.75"± O.D. METALLIC WATER (SEE NOTE 6)	201.61 201.45		NO CLEARANCE	
3	24	79.4 RT.	56+34.9 ± (a)	A	12.75"± O.D. METALLIC WATER	206.10		NO STORM DRAIN CROSSING	
--	25	--	--	--	CANCELLED BY DEPARTMENT	--			
4	26	132.4 RT.	59+59.5 ± (a)	B	TOP OF CONCRETE CAP BOTTOM OF CONCRETE CAP BOTTOM OF BOTTOM CONDUIT	201.26 200.88 199.21		1.5' CLEARANCE BELOW STORM DRAIN	
4	27	76.7 RT.	61+13.9 ± (a)	B	TOP OF T/Tg DUCT BOTTOM OF T/Tg DUCT	204.22 202.04		0.25' CLEARANCE BELOW STORM DRAIN	

PLAN SHEET	TEST HOLE	DISTANCE (FEET)	(1) STATION & BASELINE	OWNER	TYPE OF FACILITY	(2) ELEV. (FEET)	(3) CONFLICT YES/NO	(4) REMARKS	UTILITY (5) ADJUSTMENT REQUIRED

UTILITY OWNERS

A Water and Sanitary Sewer:
 County of Hanover
 Dept. of Public Utilities
 P.O. Box 470
 7516 County Complex Road
 Hanover, Virginia 23069-0470

B Telephone and Telephone Fiber Optic:
 Verizon
 2600 Brittons Hill Road
 Richmond, Virginia 23230

C Natural Gas:
 Virginia Natural Gas
 3719 Virginia Beach Boulevard
 Norfolk, Virginia 23502

NOTES:

- (1) TEST HOLE LOCATIONS ARE REFERENCED FROM THE FOLLOWING BASELINE / CENTERLINE SURVEY DATA:
 (a) ROUTE 1 BASELINE
 (b) ROUTE 54 WEST CENTERLINE
 (c) ROUTE 54 EAST CENTERLINE
- (2) ELEVATIONS SHOWN HEREON ARE TO THE TOP OF THE FACILITY UNLESS OTHERWISE NOTED.
- (3) YES OR NO: NO INDICATES NO DIRECT CONFLICT, HOWEVER, CLEARANCE MAY BE LESS THAN ACCEPTABLE TO UTILITY OWNER.
- (4) REMARKS TO INCLUDE CLEARANCE DIMENSION (REGARDLESS OF DISTANCE).
- (5) YES OR NO: INFORMATION TO BE PROVIDED BY THE VDOT DISTRICT UTILITY ENGINEER.

JMT JOHNSON, MIRMIRAN & THOMPSON
 Engineering A Brighter Future®
 272 Bendix Road, Suite 260 Virginia Beach, VA 23452

Route 1
 Hanover County, Virginia
 VDOT Project #001-66-V06, C50L, UPC #13-63

TEST HOLE SUMMARY SHEET

DRAWN BY: ELW	CADFILE #: 10-0866-017_SUM	JOB #: 10-0866-017	SCALE: N/A
CHECKED BY: JDF	DATE: 05/02/12	SHEET #: N/A	

PROJECT	SHEET NO.
XXXX-XXX-XXX	IH

FIGURE 2H - 10 SAMPLE UNDERGROUND UTILITY TEST HOLE INFORMATION SHEET

8/26/2014
2:04:32 PM

TMP Plans.dgn
Plotted By: stewartwillis

PROJECT MANAGER _____
SURVEYED BY, DATE _____
DESIGN BY _____
SUBSURFACE UTILITY BY, DATE _____

TEMPORARY TRAFFIC CONTROL

GENERAL NOTES

SEQUENCE OF CONSTRUCTION

REVISED	STATE	ROUTE	STATE	SHEET NO.
			PROJECT	
	VA.	XXX	XXX-XXX-XXX, C-50X R-20X	IJK(1)

DESIGN FEATURES RELATING TO CONSTRUCTION OR TO REGULATION AND CONTROL OF TRAFFIC MAY BE SUBJECT TO CHANGE AS DEEMED NECESSARY BY THE DEPARTMENT

GENERAL NOTES

Road Closures by Contractor are to be coordinated with the Soluda Residency Administrator Sean Trapani (804) 758-2322 and the Gloucester County school system. All road closures shall be prohibited during school operating days.

Apply Transportation Management Plan Type 'B'

Work Zone Location - Sta. 28+63.81 to Sta. 38+50.00.

Length and Width of Work Zone - 986.19' L X 22' and variable W.

Both travel lanes will be affected by project work.

Potential location for construction equipment and material storage is Rt. Sta 32+00/- and 38+00/-.

Not to exclude other standard layouts or modifications thereof, the following typical traffic control figures apply to the daily safety features employed by the Contractor:

TTC-4.0 Stationary Operation on a Shoulder
TTC-23.0 Lane Closure on a Two Lane Roadway Using Flaggers
TTC-53.0 Signaling for Project Limits

Access to adjacent residential and commercial properties shall be maintained at all times, or as directed by the Engineer.

The Contractor shall notify each affected property owner at least 24 hours in advance of the start of any work that will require the temporary closure of access.

Traffic control devices which conflict with private entrances will be placed in a manner to eliminate that conflict.

Alternate routes which will be utilized for detours are Route 17, George Washington Memorial Hwy., Route 614, Hickory Fork Rd. and Route 616, Belrol Rd.

The major types of travelers impacted by the construction of Route 615, Burling Rd. are residents and commuters.

TEMPORARY TRAFFIC CONTROL

It is not the intent of this plan to enumerate every detail which must be considered in the construction of each stage, but only to show the general features necessary to provide the proper handling of traffic.

The Contractor shall submit revised traffic control plans to the Engineer for approval prior to the beginning of any revised phase. The traffic control plan shall show all necessary traffic control devices including signs, pavement markings and channelizing devices.

The clear zone is to be free of stored materials and parked equipment. Horizontal and vertical sight distances shall not be impacted by parked construction equipment.

All areas excavated more than 2' below pavement surface which public traffic is on and within the clear zone and not protected by a positive barrier at the conclusion of each workday, shall be backfilled to form an approximate 6:1 safety wedge desirable, 4:1 minimum, against the pavement surface for the safety and protection of the public traffic. All costs for placing, maintaining and removing the 6:1 desirable, 4:1 minimum safety wedge shall be included in the price bid for other items in the contract and no additional compensation will be allowed.

All traffic control devices shall be approximately placed and moved as necessary to maintain adequate property owner access at all times. Work may require additional traffic control devices, grading and temporary pavement for passage of pedestrian, vehicular and emergency traffic through the work areas, both during and after working hours, to maintain such access.

The Contractor shall be responsible for maintaining any existing signs, unless otherwise advised by the Engineer to remove or relocate.

The Contractor is responsible for coordinating the construction, signing and traffic management plan with other adjacent projects under construction.

SEQUENCE OF CONSTRUCTION

Unless otherwise approved or directed by the Engineer, the Contractor shall plan and prosecute the work in accordance with the following:

Place Project Limit Staging
Place all erosion and sediment controls
Place Bioretention Basin and associated structures
Remove cut between 32+00/- and 37+50/-
Construct new alignment up to 21B
Place additional erosion and sediment controls
Place Detour signs and Detour traffic
Construct D605 and transition tie-ins
Pave
Complete shoulder/ditch/guardrail and slope work

Guardrail must be completely installed prior to opening the road to traffic.

The phases in this sequence of construction shall be followed unless the Contractor submits an alternate sequence and secures the approval of the Engineer for a sequence which shall both expedite construction and lessen the effect of such construction upon the travelling public.

All work is to be performed in accordance with the current MUTCD, the 2007 Road and Bridge Specifications, the 2008 Road and Bridge Standards, the 2011 Virginia Work Area Protection Manual, 2011 Supplement to the MUTCD including each manual's subsequent revisions and as directed by the Engineer.

Prior to closing lanes of a roadway or detouring traffic, local fire, rescue, and law enforcement shall be notified by the Engineer. In the event an acceptable alternate routing for emergency services cannot be obtained, the Contractor shall make accommodations to route emergency vehicles safely through the work zone under approval and direction of the Engineer.

Under no circumstances will the concurrent construction left and right of any lane be allowed unless otherwise directed by the Engineer or shown on these plans.

All erosion and sediment control measures and temporary drainage shall be in place prior to beginning any new phases of construction.

The Contractor shall provide temporary drainage, if required, to prevent ponding of water on the roadway and adjacent properties. Temporary drainage on the project is the Contractor's responsibility. The cost of the temporary drainage, other than the items that have been quantified in these plans, is included in the price bid for other drainage items and no additional compensation will be allowed.

Existing surface, aggregate base and subbase material, which will be demolished or obliterated during construction and which is suitable for maintenance of traffic, as determined by the Engineer, shall be salvaged and utilized for maintenance of traffic prior to the use of commercial materials. When not specified as a separate pay item, the removal and salvaging of existing surfaces and aggregate base and subbase material will be measured and paid for as Regular Excavation in accordance with Section 303 of the Specifications.

All proposed full depth asphalt pavement will be constructed up to the intermediate layer. The final surface course will be applied in the final phase of construction when approved by the Engineer.

When proceeding from one stage of construction to another stage of construction, any existing or construction pavement markings that do not align with the new traffic patterns and/or necessary markings shall be eradicated and re-stripped.

MAINTENANCE OF TRAFFIC

All signing for the project limits shall be done in accordance with the 2011 Virginia Work Area Protection Manual. These signs shall be installed on all state maintained roadways and remain in place for the duration of the project.

All construction signing shall be fabricated and installed in accordance with the May 2011 Virginia Work Area Protection Manual, the 2009 MUTCD, The Virginia Supplement to the MUTCD, the Standard Highway Sign Manual, The 2007 Virginia Road and Bridge Specifications and the 2008 Virginia Road and Bridge Standards.

Sign spacing shall be adjusted to fit field conditions with approval of the Engineer.

Contractor shall install 'NEW TRAFFIC PATTERN AHEAD' signs the day of all traffic shifts and remove them two weeks after the new traffic pattern has been established.

All existing signs whether shown on the plans or not shall be maintained and relocated as necessary throughout the life of the project or as directed by the engineer.

All unneeded traffic control devices shall be removed from the roadway immediately.

TRANSPORTATION OPERATIONS PLAN - CENTRAL REGION OPERATIONS

All Construction Signs as shown on TTC-53.0 shall be in place prior to commencement of Phase I construction activities.

Due to road closure the Regional Transportation Operations Center shall be reached as follows: TRANSPORTATION OPERATIONS PLAN

1) The process to notify the Regional Traffic Operation Center to place road/lane closure information on the 511 system and VA Traffic will be:

- Contractor is to advise the VDOT project inspector and/or Construction Manager of planned road/lane closures a minimum of 24 hours in advance of proposed road/lane closure.
- Construction Manager to advise Residency Maintenance Manager of proposed road/lane closure. Maintenance Manager is to have (VA Traffic) operator enter data into VA Traffic, and also advise Smart Traffic Center.

2) The following is a list of local emergency contact agencies:
Virginia State Police - (800) 582-8350
Haz-Mat Center (if spill involved) - 911

3) Procedures to respond to traffic incidents that may occur in the work zone:

- Contractor to notify Virginia State Police and VDOT Inspector in charge and Regional Traffic Operation Center.
- Depending upon severity of incident, contractor may have to shut down work.
- Upon arrival on scene, Virginia State Police will determine the response necessary to allow traveling public around incident.
- Inspector to notify Construction Manager/Residency Administrator of incident and take pictures as necessary, especially pictures of contractor's work zone to verify the proper setup.

4) Process of notification of incident to be followed is:

- Contractor to call Construction Manager Bill Collins, (804) 690-4574. Construction Manager shall notify the following:
 - Regional Traffic Operation Center, Shift Supervisor (804) 796-4520 or 1-866-378-7743
 - Project Maintenance of Traffic Coordinators, Michael Coffey, (540) 899-4214
 - Residency Administrator: Sean Trapani (804) 758-2322 x113
 - Area Construction Engineer, Michael Coffey, (540) 899-4214
 - District Work Zone Safety Coordinator, Jeff Stone (540) 899-4547 or (540) 907-8621
 - Regional Traffic Engineer, Dale Tolten, P.E. (804) 524-6119
 - Central Area Traffic Engineer, Peter Hedrich (540) 899-4540
 - District Public Affairs Manager, Kelly Hannon (540) 374-3344
 - Gloucester County Sheriff's Office, Sheriff, DW Warren, Jr., (804) 693-3890
 - Gloucester County Fire & Rescue (804) 693-3890

5) The Virginia State Police will take control of the incident and direct its clearing and restoration to normal traffic conditions.

6) The Virginia State Police report of the incident will be reviewed by the Residency Administrator to determine if any modification of the Temporary Traffic Control Plan is necessary. If it is determined that it is necessary to alter the plan, a meeting will be called with the contractor, VDOT project personnel, VDOT traffic safety representatives and the Virginia State Police (if necessary) to discuss modification and implementation of an improved traffic control plan.

The Contractor is responsible for coordinating the construction signing and Traffic Management Plan with other adjacent projects under construction.

PROJECT	SHEET NO.
XXX-XXX-XXX	IJK(1)

8/26/2014
2:05:26 PM

TMP Plans/Sign
Plotted By: Stewart Hillis

PROJECT MANAGER _____
SURVEYED BY, DATE _____
DESIGN BY _____
SUBSURFACE UTILITY BY, DATE _____

• = Detour Signing

PROJECT LOCATION

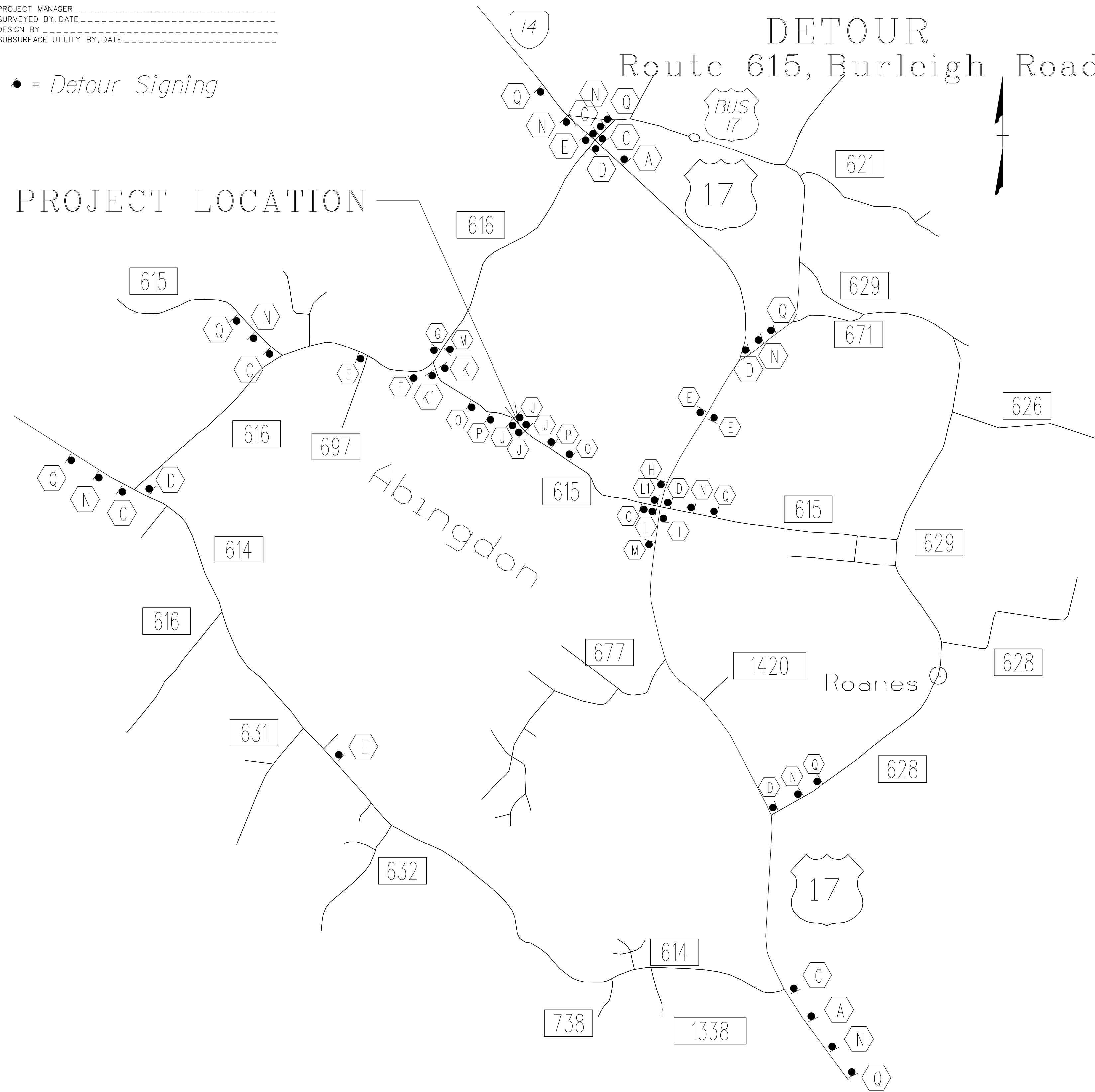

REVISED	STATE	ROUTE	STATE PROJECT	SHEET NO.
	VA.	XXX	XXXX-XXX-XXX, C-50X R-20X	IJK(2)

DESIGN FEATURES RELATING TO CONSTRUCTION OR TO REGULATION AND CONTROL OF TRAFFIC MAY BE SUBJECT TO CHANGE AS DEEMED NECESSARY BY THE DEPARTMENT

Location & Design
Fredericksburg, Virginia
TRAFFIC ENGINEER

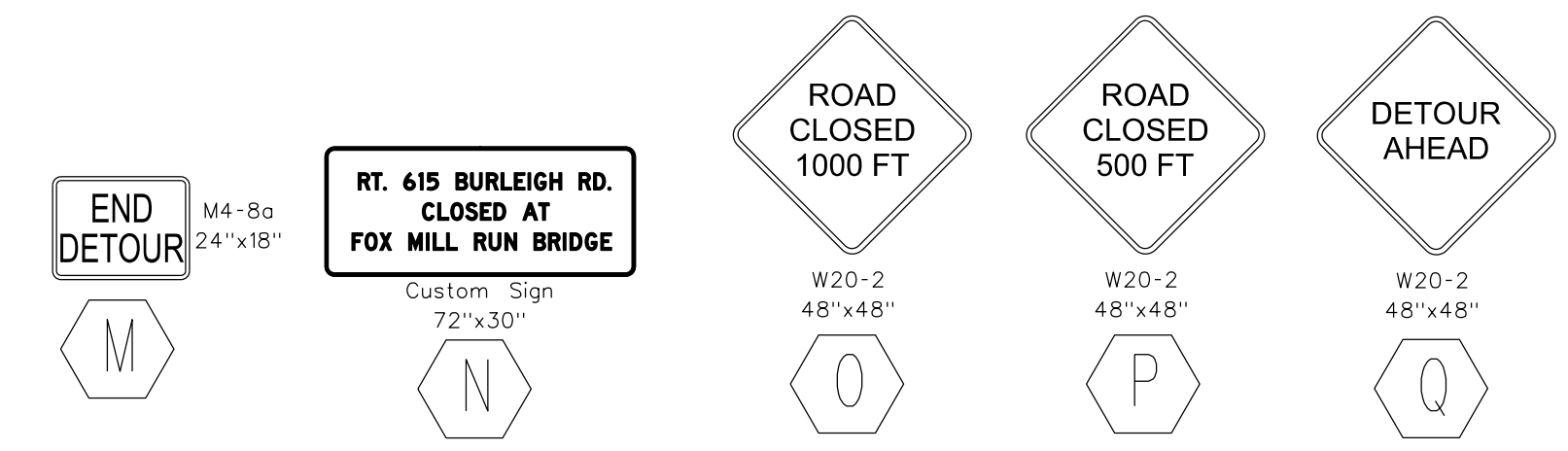
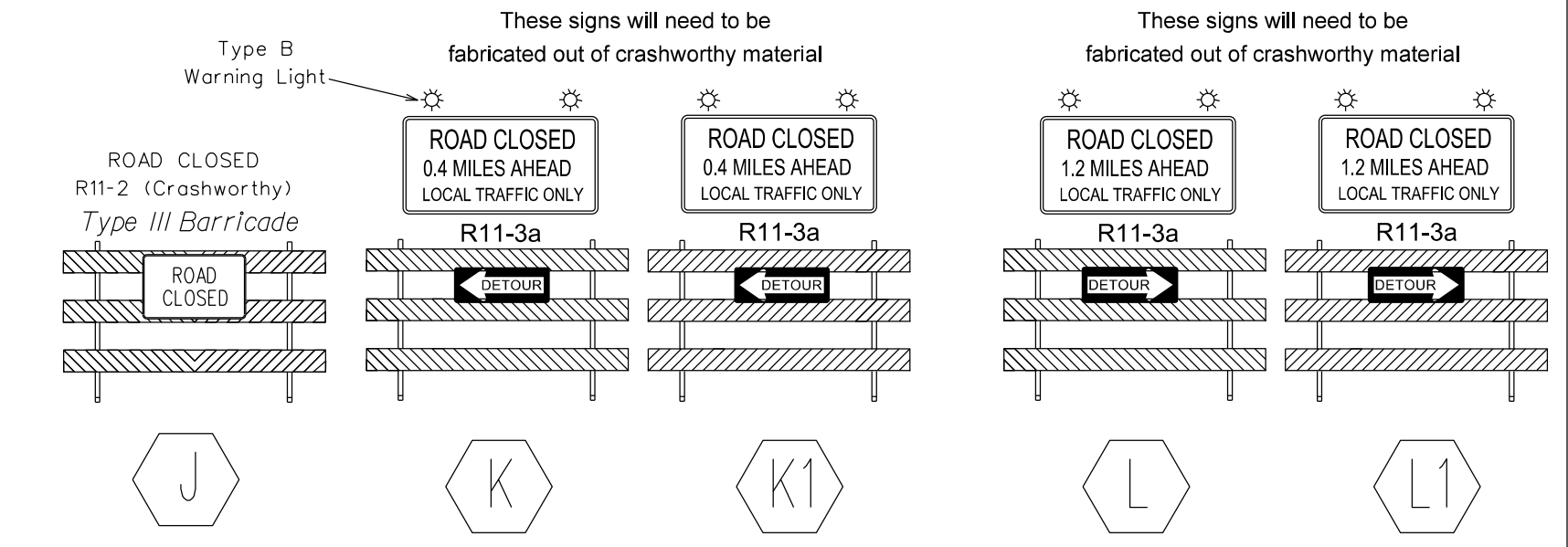
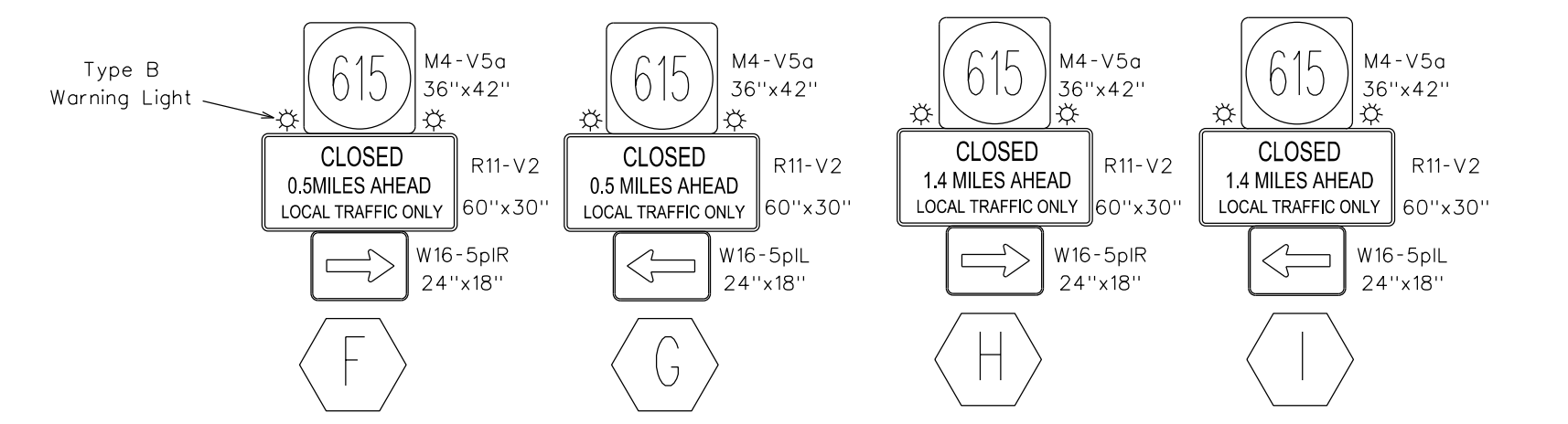
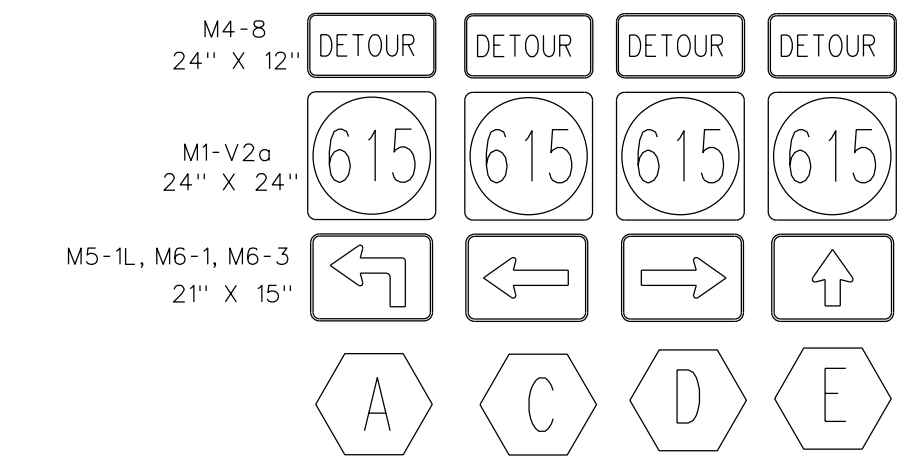

See Constr. Sign Sch. Sheet IK(7) for Summary

NOT TO SCALE	PROJECT XXXX-XXX-XXX	SHEET NO. IJK(2)
--------------	-------------------------	---------------------

Cell Revised 12/11/12

FIGURE 2H - 12 SAMPLE TRAFFIC MAINTENANCE PLAN (TMP) SHEET

8/26/2014
2:06:21 PM

TMP Plans.dgn
Plotted By: stewartlwills

PROJECT MANAGER _____
SURVEYED BY, DATE _____
DESIGN BY _____
SUBSURFACE UTILITY BY, DATE _____

TEMPORARY TRAFFIC CONTROL and Sequence of Construction

REVISED	STATE	ROUTE	STATE PROJECT	SHEET NO.
	VA.	XXX	XXXX-XXX-XXX, C-50X R-20X	11(3)
DESIGN FEATURES RELATING TO CONSTRUCTION OR TO REGULATION AND CONTROL OF TRAFFIC MAY BE SUBJECT TO CHANGE AS DEEMED NECESSARY BY THE DEPARTMENT				
Location & Design Fredericksburg, Virginia ROADWAY ENGINEER				
BURLEIGH ROAD				

PURPOSE:

Reconstruction of sharp curve.

LEGEND:



Phase 1

• = Group 2 Channelizing Device (Top)

PHASE 1

SUGGESTED SEQUENCE OF OPERATIONS:

1. Place all sediment and erosion controls prior to commencement of excavation activities.
2. Place "TRUCKS ENTERING HIGHWAY" signs. Place 350' to 500' from entrance location.
3. Remove cut between Sta. 32+/- and 37+30+/-.
4. Place detour signing - detour traffic.

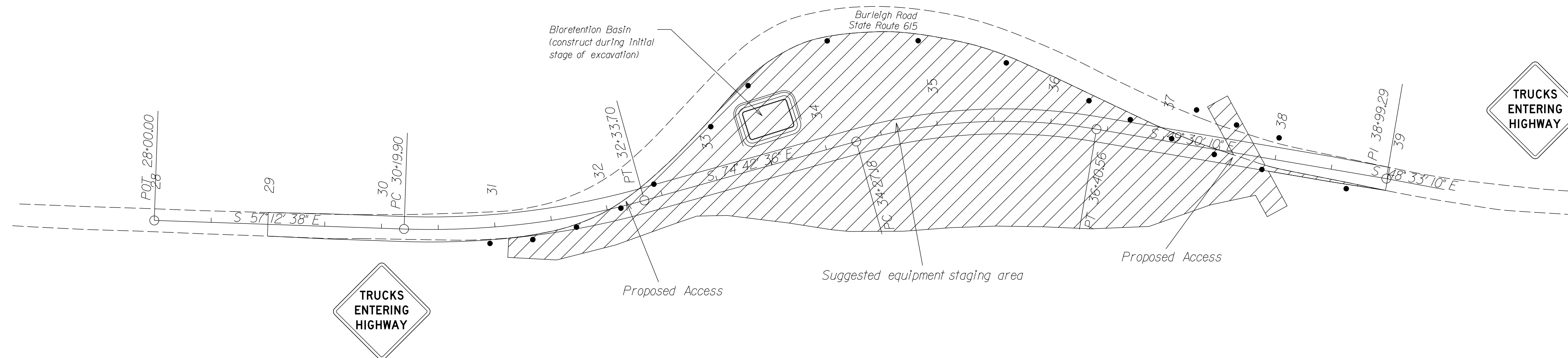

TTC DETAILS - SEQUENCE OF CONSTRUCTION		
PHASE	SEQUENCE	TTC
1	Place Project Limits signing Place all E&S controls. Remove cut between Sta 32+/- and 37+30+/-	TTC-53.0 Signing for Project Limits TTC-4.0 Stationary Operation on a Shoulder TTC-63.0 Work Truck/Excavation Entrance

Trucks Entering Highway signs shall be removed or covered in accordance with the 2011 Work Area Protection Manual on a daily basis during non-working hours. These signs shall only be visible to traffic during work operations in which trucks are required to enter and exit the work zone and while such work is actively occurring.

SCALE 0 50' 100'	PROJECT XXXX-XXX-XXX	SHEET NO. 11(3)
---------------------	-------------------------	--------------------

Cell Revised 12/11/12

FIGURE 2H - 13 SAMPLE TRAFFIC MAINTENANCE PLAN (TMP) SHEET

8/26/2014
2:07:04 PM

TMP Plans.dgn
Plotted By: stewartwillis

PROJECT MANAGER _____
SURVEYED BY, DATE _____
DESIGN BY _____
SUBSURFACE UTILITY BY, DATE _____

TEMPORARY TRAFFIC CONTROL and Sequence of Construction

PURPOSE:
Reconstruction of sharp curve.

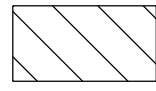
LEGEND:
 Phase 2
 • - Group 2 Channelizing Device (Top)

PHASE 2 (if necessary)
 DETOUR OF TRAFFIC: 3 weeks See Detour Signing Sheet IK(2)

REVISED	STATE	ROUTE	STATE PROJECT	SHEET NO.
	VA.	XXX	XXXX-XXX-XXX, C-50X R-20X	IJ(4)

DESIGN FEATURES RELATING TO CONSTRUCTION OR TO REGULATION AND CONTROL OF TRAFFIC MAY BE SUBJECT TO CHANGE AS DEEMED NECESSARY BY THE DEPARTMENT

Location & Design
Fredericksburg, Virginia
ROADWAY ENGINEER
BURLEIGH ROAD

SUGGESTED SEQUENCE OF OPERATIONS:
 Place additional drainage and erosion & sediment controls.
 While placing D605, construct road transitions.
 Place roadway items - pavement structure to IM-19.0A.
 Set up temporary traffic control as necessary.

OPEN ROADWAY TO THRU TRAFFIC:
 Final paving and line marking operation.
 Complete shoulder/ditch/guardrail and slope work.

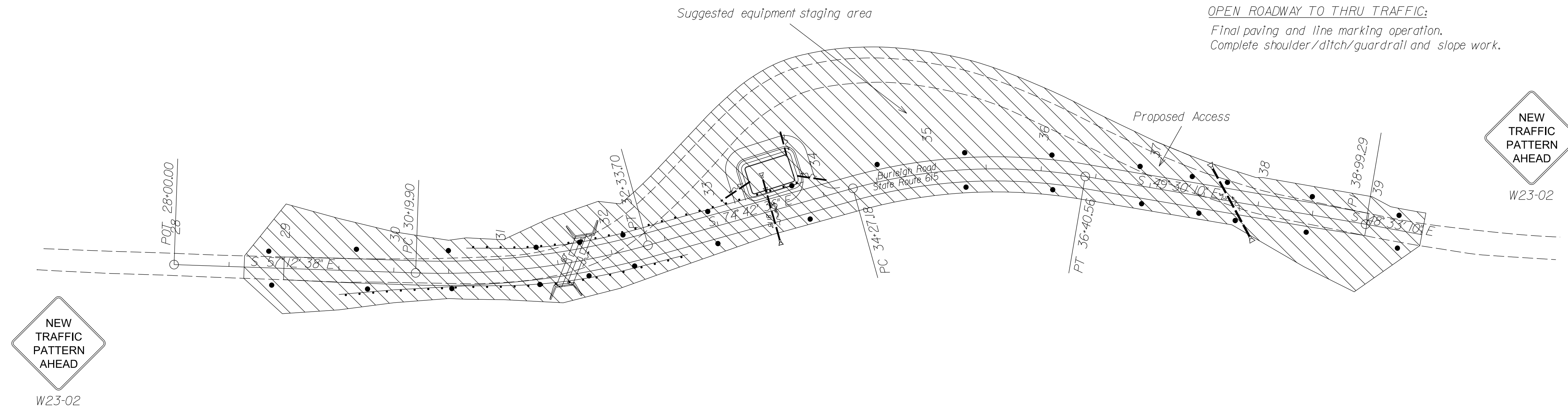

TTC DETAILS - SEQUENCE OF CONSTRUCTION		
PHASE	SEQUENCE	TTC
2	Place additional E&S controls. Complete all road/paving items. Complete guardrail/shoulder/ditch and slope work. Remove E&S controls, seed all areas.	TTC-4.0 Stationary Operation on a Shoulder TTC-23.0 Lane Closure on a Two-Lane Roadway using Flaggers

SCALE 0 50' 100'	PROJECT XXXX-XXX-XXX	SHEET NO. IJ(4)
---------------------	-------------------------	--------------------

Cell Revised 12/11/12

FIGURE 2H - 14 SAMPLE TRAFFIC MAINTENANCE PLAN (TMP) SHEET

8/27/2014
8:36:52 AM

General Notes Sheet.dgn
Plotted By: stewartlwills

PROJECT MANAGER _____
SURVEYED BY, DATE _____
DESIGN BY _____
SUBSURFACE UTILITY BY, DATE _____

REVISED	STATE		SHEET NO.
	ROUTE	PROJECT	
	VA.	xx XXXX-XXX-XXX, RW-20X, C-50X	2

DESIGN FEATURES RELATING TO CONSTRUCTION OR TO REGULATION AND CONTROL OF TRAFFIC MAY BE SUBJECT TO CHANGE AS DEEMED NECESSARY BY THE DEPARTMENT

GENERAL NOTES

GRADING

- G-1 The grade line denotes top of finished pavement unless shown otherwise on typical sections or plans.
- G-3 Earthwork quantities on this project are based on anticipated settlement and may require adjusting during construction. Payment will be made only for quantities actually moved.
- G-4 The cost of removal and disposal of all existing concrete items located in the area to be graded, including, but not limited to the following, shall be included in the price bid for regular excavation: sidewalks, curb, gutter and drainage pipes.
- G-5 The excavation of unsuitable material as specified on these plans is based on previously conducted subsurface soil investigation. If, during construction, it is deemed necessary to change the depth more than one foot, or the limits of such excavation, such change is to be made at the direction of the Engineer and measurement and payment shall be made in accordance with Section 303 of the applicable VDOT Road and Bridge Specifications.
- G-6 The borrow material for this project shall be a minimum CBR _____ or as approved by the Materials Engineer.
- G-7 Material from regular excavation which is suitable for stabilization with hydraulic cement (lime) shall be placed in the top portion of the subgrade.

DRAINAGE

- D-1 The locations of all drainage structures shown on these plans are approximate only, with the exception of structures showing specific stations, special design bridges and storm sewers. The "h" dimensions shown on the plans for drop inlets and junction boxes and the L, F, dimensions shown for manholes are approximate.
- D-2 If, during construction, the culvert invert elevations shown on the plans are found to differ significantly from the elevations of the stream or swale in which the culvert shall be placed, the Engineer will confer with the Project Drainage Designer before installing the culvert.
- D-6 Pipes shall conform to any of the allowable types shown on sheet number 2D, within the applicable fill height limitations. For strength, sheet thickness, or class designation; available sizes; height of fill limitations; and method of bedding required for a particular height of cover, see Standards PC-1 and PB-1. Structural plate pipe may be substituted for corrugated pipe of the same size and a structural plate pipe arch may be substituted for a corrugated pipe arch of the same size, provided the substitution complies with the applicable VDOT Road and Bridge Standards PC-1 and PB-1.
- D-10 The proposed riprap may be omitted by the Engineer if the slope designated for placement of riprap is found to be comprised of solid rock or closely consolidated boulders with soundness, size and weight equal to, or exceeding, the specifications for the proposed riprap.
- D-12 All existing drainage facilities labeled "To Be Abandoned" shall be left in place, backfilled and plugged in accordance with the VDOT Road and Bridge Standard PP-1. Basis of Payment will be C.Y. of Flowable Backfill.
- D-13 Existing drainage facilities being utilized as a part of the drainage system, and designated on the plans "To Be Cleaned Out" shall be cleaned as directed by the Engineer. The cost incidental to this shall be included in the contract price for other items.
- D-14 Existing drainage facilities being utilized as a part of the drainage system, and designated on the plans "To Be Cleaned Out", shall be cleaned as directed by the Engineer. The cost incidental to this shall be included in the contract price for other items.
- D-15 Drop inlets with "H" less than standard minimum shall be considered as standard and quantities adjusted accordingly. Where noted on the plans or as directed by the Engineer, concrete pipe with less than standard minimum cover shall have bedding material placed up to half the pipe diameter and shall be minimum of Class III.
- D-16 When CG-6 or CG-7 is specified on a radius (such as at a street intersection), the Engineer may approve a decrease in the cross slope of the gutter to facilitate proper drainage.

PAVEMENT

- P-1 If any settlement occurs in concrete pavement adjacent to bridges prior to acceptance of the project by the Department, the contractor shall restore the pavement to the original grade either by the mud jack method or by replacing the pavement. In the event the pavement cracks or becomes damaged, it shall be replaced, if directed by the Engineer.
- P-2 The pavement materials on this project will be paid for on a tonnage basis. The weight will vary in accordance with the specific gravity of the aggregates and the asphaltic content of the mix actually used to secure the design depth. The weight of the asphalt concrete is based on 95% of the theoretical maximum density.

INCIDENTALS

- I-1 Two Reflectorized Railroad Grade Crossing Crossbuck Signs, complete with posts, SHALL BE FURNISHED AND ERECTED BY THE RAILROAD COMPANY.
- I-2 Two Reflectorized Railroad Advance Warning Signs W10-1 complete with two approved posts, WILL BE FURNISHED AND ERECTED BY STATE FORCES.
- I-3 Service Roads are to be constructed, and private entrances connected thereto prior to the permanent severing of private entrances by other phases of the proposed construction.
- I-4 All trees located within the Clear Zone or within a minimum of 30 feet of the edge of pavement, within the limits of the right of way or construction easement, unless otherwise noted on plans or directed by the Engineer, shall be removed, as provided for a Section 301 of the applicable VDOT Road and Bridge Specifications.
- I-5 That portion of the right of way lying within the Clear Zone or within a minimum of 10 feet from the edge of pavement or surfacing or within the limits of the construction slopes beyond 10 feet, shall be cleared and grubbed in accordance with the applicable VDOT Road and Bridge Specifications, Section 301, where sufficient right of way or construction easement is provided.
- I-6 Certain trees shall be preserved as noted on plans or as directed by the Engineer.
- I-7 Where Standard slope roundoffs would damage trees, bushes or other desirable vegetation, they shall be omitted when so ordered by the Engineer.
- I-8A Clearing and grubbing shall be confined to those areas needed for construction. No trees or shrubs in ungraded areas on this project shall be cut without permission of the Engineer.
- I-10 St'd. RM-1 Right of Way monuments shall be set by the Contractor.
- I-13 Salvaged guardrail materials not used in the new construction shall become the property of the Department and the Contractor shall deliver and store, at no additional cost to the Department, the unused materials at the Department's maintenance yard at _____ during the Department's normal working hours.
- I-14 Salvaged guardrail materials not used in the new construction shall become the property of the Contractor and shall be disposed of at a licensed landfill, recycled or be retained by the Contractor.
- I-15 Where Guardrail GR-2 or GR-8 is shown on the plans and in the summaries, either new guardrail or reused guardrail beam shall be used as provided elsewhere in these plans. The total quantities have been proportioned between new and reuse guardrail based on an estimate of the amount of existing beam that is reuseable. The Contractor will be paid for the actual quantities of Guardrail, St'd. GR-2 or St'd. GR-8 or Reuse Guardrail, St'd. GR-2 or St'd. GR-8 as determined by the Engineer.
- I-16 The "underground utilities" survey data on this project has been provided by consultant and copies are available from the Department.
- I-17 For method of constructing Straight-Line Taper Lanes in curb and/or curb and gutter sections, see typical details on Sheet _____.
- I-18 All pavement markings and traffic flow arrows shown on the roadway construction plans are schematic only. The actual location and application of pavement markings shall be in accordance with Section 704 of the applicable VDOT Road and Bridge Specifications, MUTCD, sequence of construction/traffic control plans, pavement marking plan sheets ... thru ... and as directed by the Engineer.
- I-19 The following sources, under contract with VDOT, have provided information on this project:
Utility Designation - So-Deep Inc.
If questions or problems arise during construction, please contact the Project Designer. DO NOT CONTACT THE OUTSIDE SOURCES.
- I-20 The Official Electronic .tif Version of the plans will override the paper copies or prints of specific layers.
Portions of this plan assembly have been CADD generated. To assist in the construction of the project electronic files will be available to the prime contractor after award of the contract.
- I-21 All electronic plan assemblies will include the construction plans in two formats: .tif files and MicroStation format (.dgn) files. Only the .tif files will be considered as part of the official plan assembly.
The MicroStation format (.dgn) files are furnished only as information for the contractor. These plans are developed in layers (levels) to aid in readability. However, the construction items may or may not be in the proper layering scheme as described in the VDOT CADD Manual. The MicroStation files will only match the scanned files if all levels are turned on. A MicroStation Software license is required to be able to read these files.

EROSION AND SILTATION CONTROL

- E-1 The temporary erosion and siltation control items shown on the E&S Control Plan are intended to provide a general plan for controlling erosion and siltation within the project limits. The E&S Control Plan is based on field conditions at the time of plan development and an assumed sequence of construction. The contractor, in conjunction with the Project Engineer and/or Environmental Monitor, shall adjust the location, quantity and type of erosion and siltation control items required based on the actual field conditions encountered at the time of construction and the selected sequence of construction.
- E-2 The areas beyond the project's construction area are to be protected from siltation. Perimeter controls such as filter barrier, silt fence, diversion dikes, turbidity curtains, etc. shall be installed prior to any grubbing operations or other earth moving activities.

STORMWATER MANAGEMENT

- S-1 CLEARING AND GRUBBING OF SWM BASIN SITE - The area where the dam is to be constructed and the area upstream of the dam, to an elevation equal to the crest of the dam (maximum ponded water elevation), shall be cleared and grubbed in accordance with Section 301 of the applicable VDOT Road and Bridge Specifications.
- S-2 SWM BASIN DAM CONSTRUCTION - The dam for detention basins (no permanent pool) shall conform to the details contained in the plans and shall be constructed in accordance with Section 303 of the applicable VDOT Road and Bridge Specifications. The native material on which the dam will set shall meet the specifications for AASHTO Type A-4 or finer material. Where the native material does not meet this requirement, the area beneath the dam is to be excavated a minimum of 4" and backfilled with a material meeting the AASHTO Type A-4 or finer classification unless otherwise specified in the plans. The material used for the embankment of the dam shall be AASHTO Type A-4 or finer or otherwise specified in the plans. Dams with foundation and embankment material not meeting the above requirements or dams greater than 15' in height, or dams for retention basins (permanent pool) shall incorporate a membrane-lined trench, a homogenous embankment with seepage controls, a zoned embankment or other such approved designs as specified in the plans.
- S-3 SWM BASIN OUTLET PIPE - The pipe culvert under or through the dam for detention basins (no permanent pool) shall be reinforced concrete pipe with rubber gaskets in accordance with Section 232 and 212 of the applicable VDOT Road and Bridge Specifications. A concrete cradle shall extend the full length of the pipe culvert in accordance with the Standard Drawings. The connection between the pipe culvert and the SWM-1 Drainage Structure (or other control structure) shall be made watertight as approved by the Engineer and the cost shall be included in the price bid for pipe.
- S-4 The SWM-1 Drainage Structure (or other control structure) shall have 4" high numbers and 1" wide stripes painted at 1' intervals as shown on the Standard Drawings or detail sheets. The numbers and stripes are to be installed at the time of the initial installation of the SWM-1 Drainage Structure (or other control structure). Paint and application shall be in accordance with Section 231 and 411 of the applicable VDOT Road and Bridge Specifications and the cost is to be included in the price bid for the applicable structure.

MAINTENANCE OF TRAFFIC

Maintenance of traffic during construction shall be in accordance with section 104.04 of the 2002 VDOT Road and Bridge Specifications.

There will be no lane closures during rush hours (5:30 AM to 9:00 AM and 3:30 PM to 6:00 PM) unless otherwise directed by the engineer.

Lane closures or work that restricts traffic flow will not be permitted on Saturdays, Sundays & holidays from noon the day before a holiday until noon the day after a holiday unless approved by the engineer. When a holiday falls on a Friday, lane closures will not be permitted from noon on Thursday until noon on Monday. When a holiday falls on a Monday, lane closures are not permitted from noon on Friday until noon on Tuesday.

Once the surface course is placed, no equipment exceeding 4 tons is to be put on the trail and must be approved by the engineer.

PROJECT	SHEET NO.
XXXX-XXX-XXX	2

FIGURE 2H - 15 SAMPLE GENERAL NOTES SHEET

8/27/2014
8:48:36 AM

Typical Section Idgn
Plotted By: stewart@illinois

PROJECT MANAGER _____
SURVEYED BY, DATE _____
DESIGNED BY _____
SUBSURFACE UTILITY BY, DATE _____

TYPICAL SECTION SHEET

DESIGN FEATURES RELATING TO CONSTRUCTION OR TO REGULATION AND CONTROL OF TRAFFIC MAY BE SUBJECT TO CHANGE AS DEEMED NECESSARY BY THE DEPARTMENT

REVISED	STATE	FEDERAL AID PROJECT	ROUTE	STATE PROJECT	SHEET NO.
	VA.		XXX	XXXX-XXX-XXX, R-20X C-50X	2A

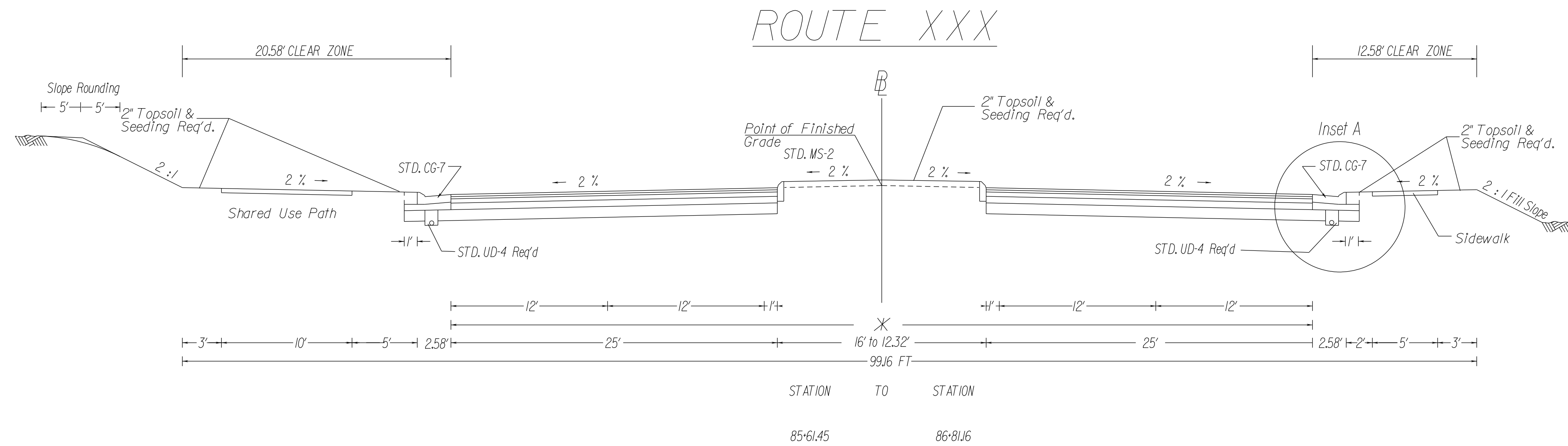

* Transition from 66' to 55' from station XX+XX.XX to station XX+XX.XX

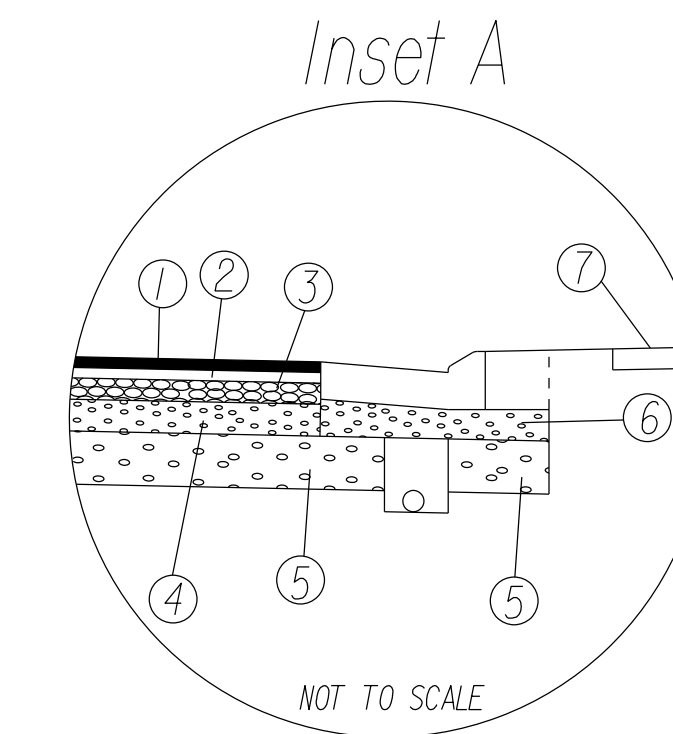

- ① ASPHALT CONC. TYPE SM-12.5A @ 220 LBS PER SQ. YD.
- ② 2" ASPHALT CONC. TYPE IM-19.0A
- ③ 4" ASPHALT CONC. BASE TYPE BM-25.0A
- ④ 6" AGGREGATE BASE MATERIAL, TYPE I, NO. 21B
- ⑤ 10" SELECT MATERIAL (SEE SPECIAL PROVISION)
- ⑥ 4" & VAR AGGREGATE BASE MATERIAL, TYPE I, NO. 21B
- ⑦ 4" HYDRULIC CEMENT CONCRETE SIDEWALK
- ⑧ ASPHALT CONC. TYPE SM-9.5A @ 165 LBS PER SQ. YD.

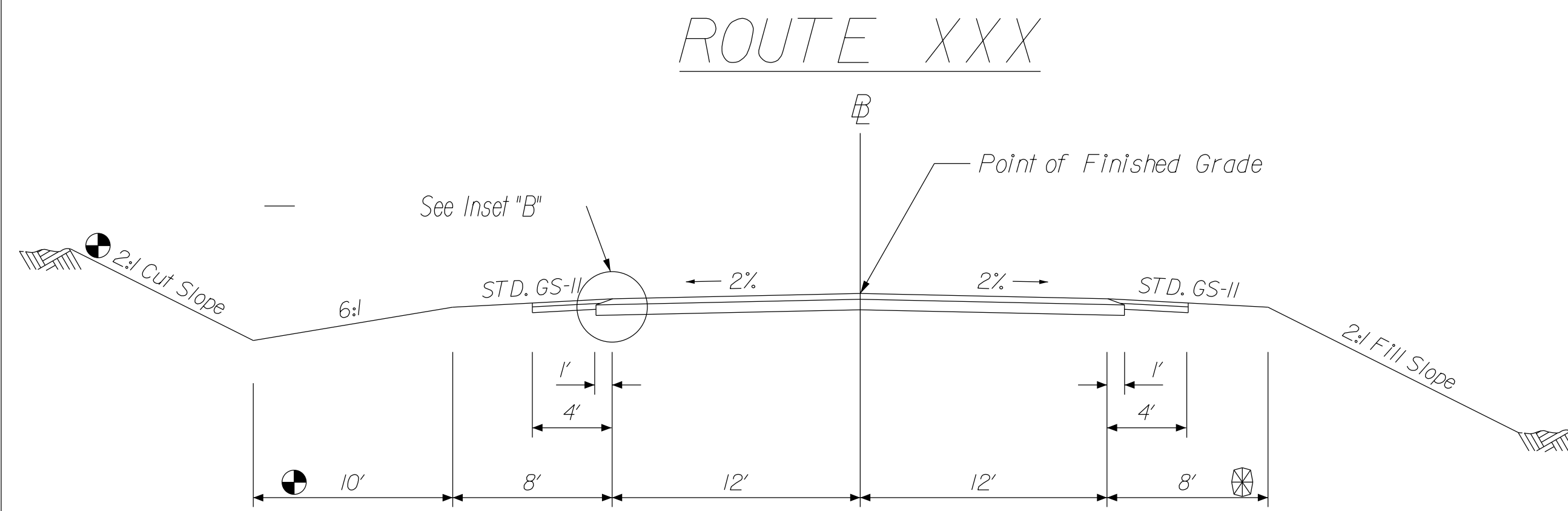

Stations: XX+XX.XX to XX+XX.XX
(Stations XX+XX.XX to XX+XX.XX to be resurfaced)

⊗ 11' Shoulder where guardrail is required.

⊙ Use 1.5:1 Cut Slope W/No Slope Rounding and 6' Ditch Rt. of Station XX+XX.XX to XX+XX.XX

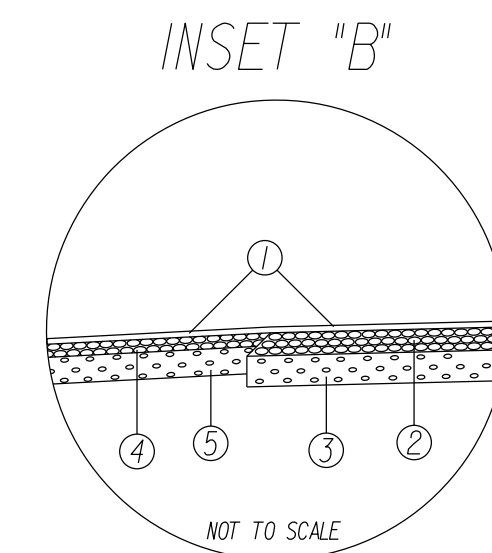

- ① ASPHALT CONCRETE TYPE SM-9.5D @ 165 LBS PER SQ. YARD
- ② 7 IN ASPHALT CONCRETE BASE COURSE TYPE BM 25.0
- ③ 10 IN AGGREGATE BASE MATERIAL, TYPE I, NO. 21B
- ④ 3 IN ASPHALT CONCRETE BASE COURSE TYPE BM 25.0
- ⑤ 6 IN AGGREGATE BASE MATERIAL, TYPE I, NO. 21B

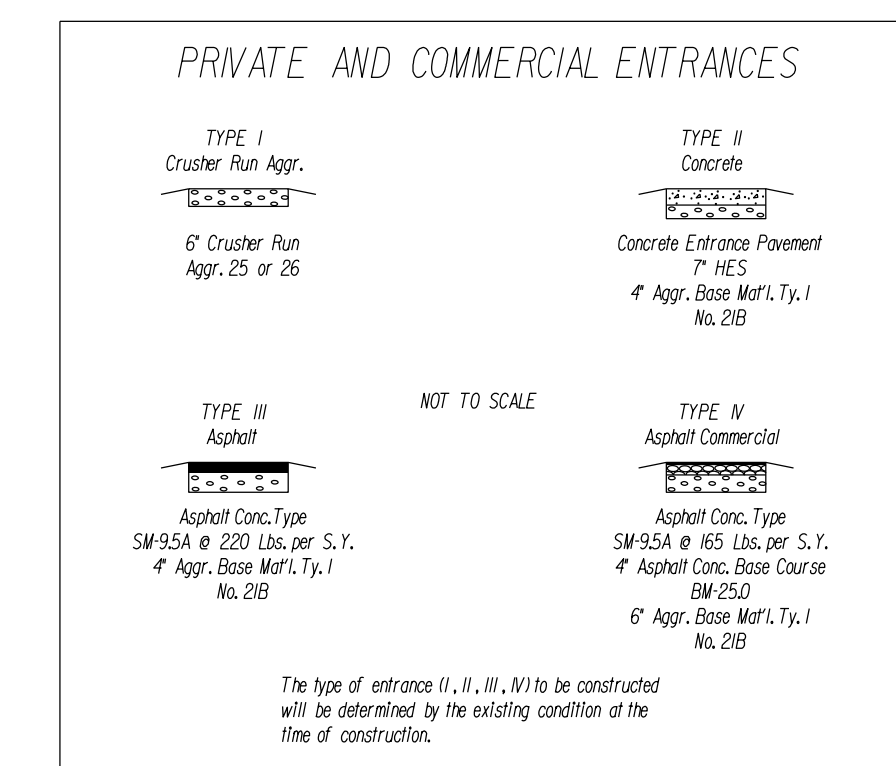

PLAN NO.	PROJECT	FILE NO.	SHEET NO.
	XXXX-XXX-XXX		2A

FIGURE 2H - 16 SAMPLE TYPICAL SECTION SHEET

8/27/2014
10:00:49 AM

Typical Section 2.dgn
Plotted By: stewart.williams

PROJECT MANAGER _____
SURVEYED BY, DATE _____
DESIGN BY _____
SUBSURFACE UTILITY BY, DATE _____

DESIGN FEATURES RELATING TO CONSTRUCTION OR TO REGULATION AND CONTROL OF TRAFFIC MAY BE SUBJECT TO CHANGE AS DEEMED NECESSARY BY THE DEPARTMENT

REVISED	STATE	FEDERAL AID PROJECT	ROUTE	STATE PROJECT	SHEET NO.
	VA.		XXX	XXXX-XXX-XXX RW-20X, C-50X	2B

TYPICAL SECTIONS

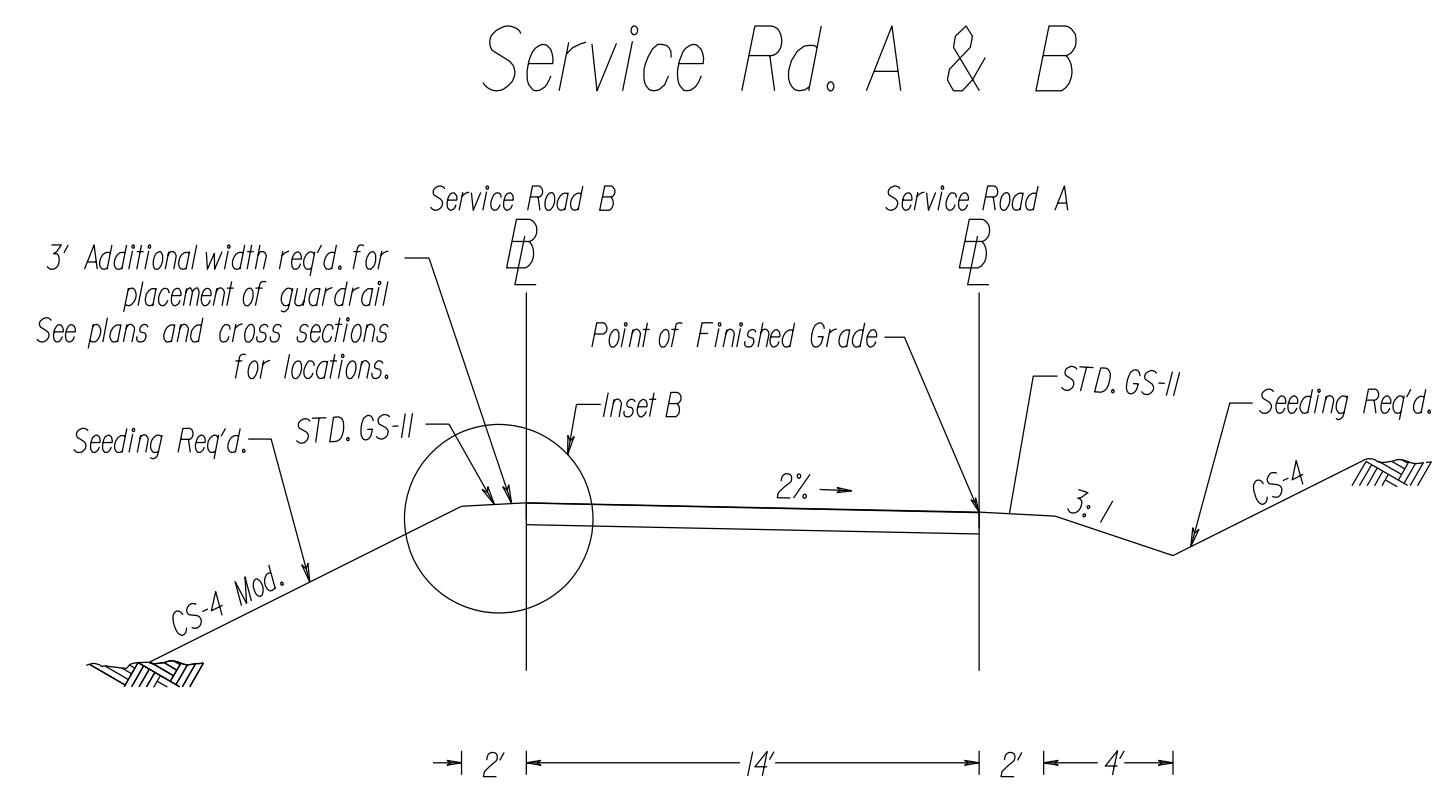

LOCATION	STATION	TO	STATION
Service Rd. A	10+12	~	44+86.65
Service Rd. B	10+11.32	~	57+02.07

Note: CS-4 Mod. in Fills Section 2.5:1 Max.

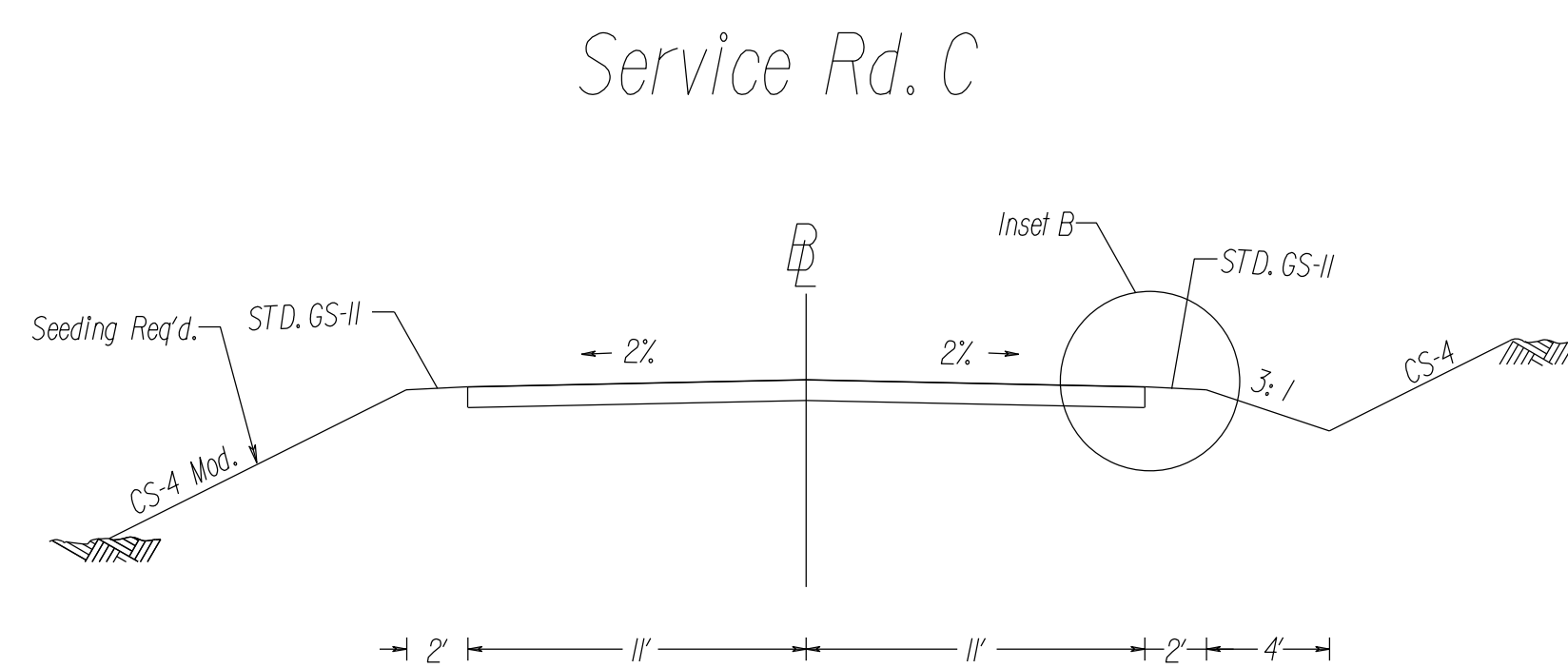

LOCATION	STATION	TO	STATION
Service Rd. C	10+33	~	13+51.32

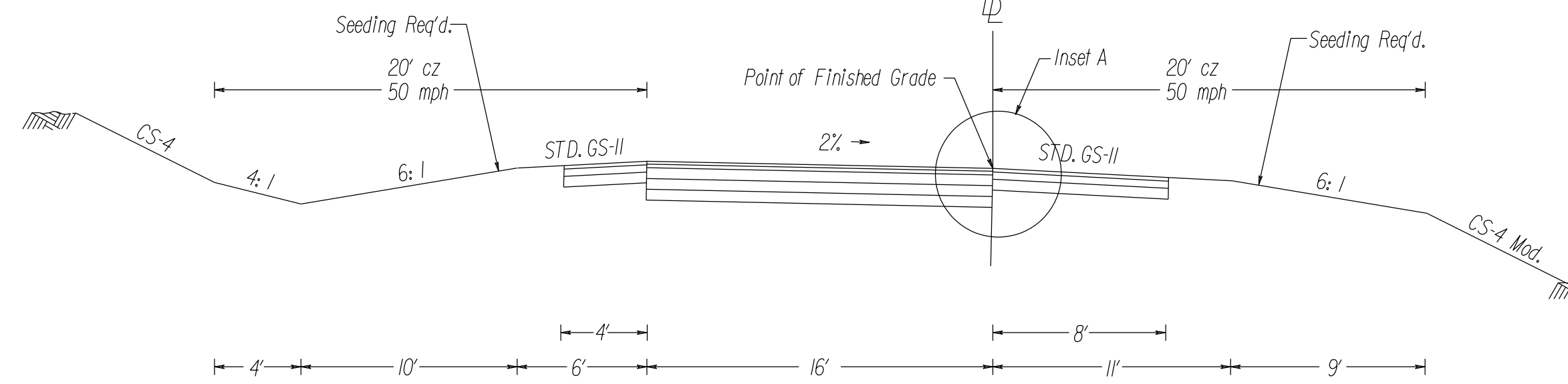

LOCATION	STATION	TO	STATION
Loop A	10+00	~	33+09.52
Ramp B	10+12	~	13+39.88
Ramp C	10+12	~	33+49.19
Ramp D	10+24	~	20+47.97

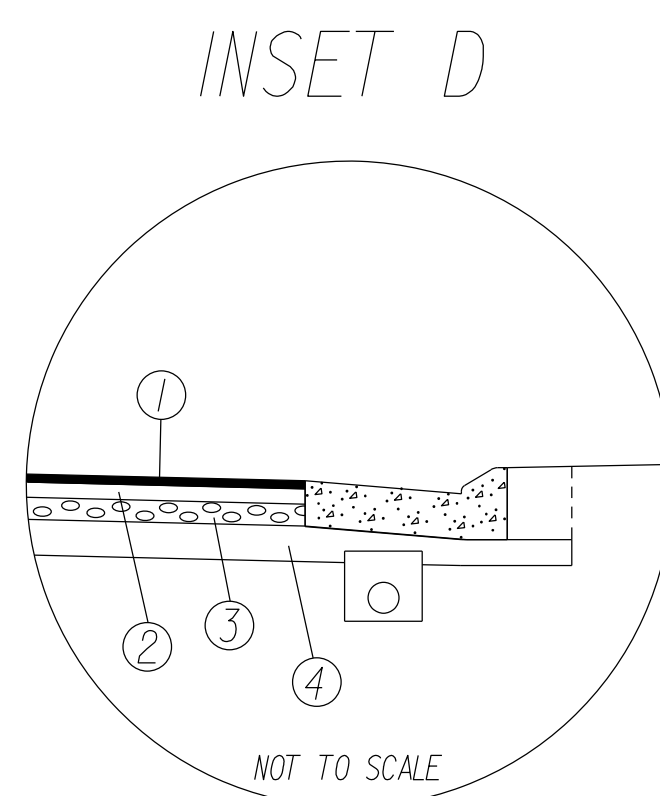

- PAVEMENT DESIGN (CURB & GUTTER SECTION & ROUNDABOUT APPROACH)
- 1 ASPHALT CONCRETE SURFACE COURSE TYPE SM-9.5A @ 165 LBS. PER SQ. YD.
 - 2 2.5" ASPHALT CONCRETE BASE COURSE TYPE BM-25.0A
 - 3 3" AGGREGATE BASE MATERIAL, TYPE 1, NO. 21B
 - 4 8" SELECT MATERIAL (SEE SPECIAL PROVISION)

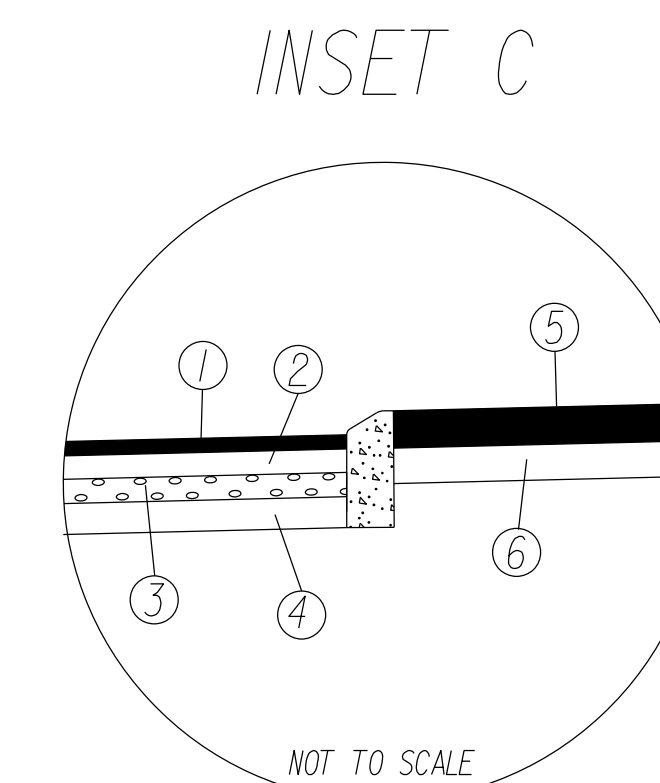
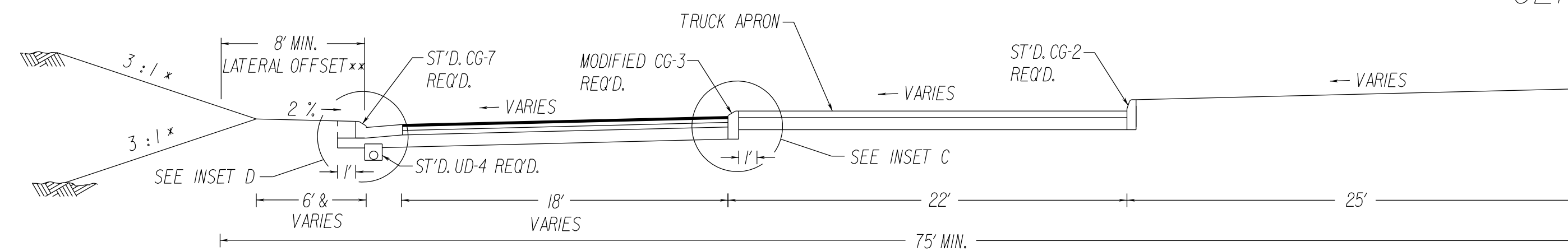

- 1 ASPHALT CONCRETE SURFACE COURSE TYPE SM-9.5A @ 165 LBS. PER SQ. YD.
- 2 2.5" ASPHALT CONCRETE BASE COURSE TYPE BM-25.0A
- 3 3" AGGREGATE BASE MATERIAL, TYPE 1, NO. 21B
- 4 8" SELECT MATERIAL (SEE SPECIAL PROVISION)
- 5 7" HYDRAULIC CEMENT CONCRETE STAMPED, COLORED & REINFORCED (REINFORCED WITH 6" X 12" - W5.5 X W4)
- 6 8" AGGREGATE BASE MATERIAL, TYPE 1, NO. 21B

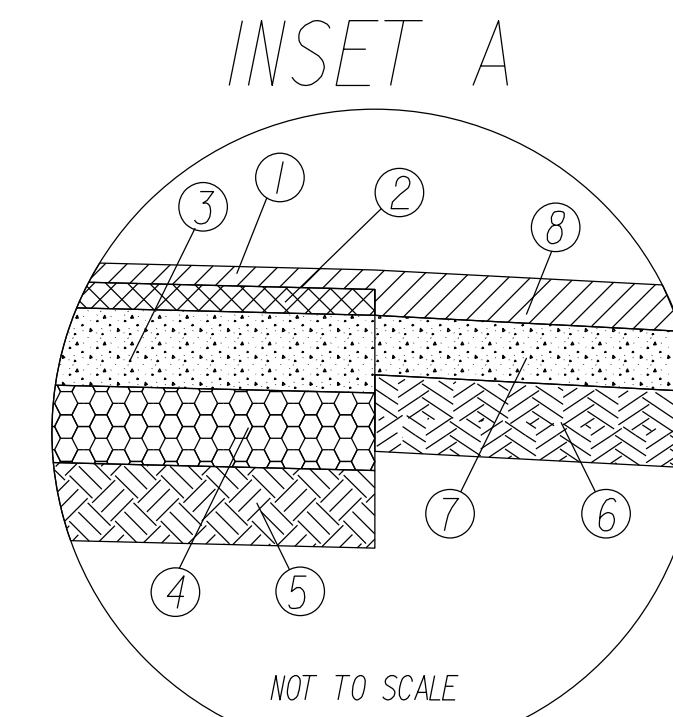

- 1 ASPHALT CONCRETE SURFACE COURSE TYPE SM-12.5D @ 180 LBS. PER SQ. YD.
- 2 ASPHALT CONCRETE TYPE 1M-19D @ 220 LBS. PER SQ. YD.
- 3 6" ASPHALT CONCRETE BASE COURSE TYPE BM-37.5
- 4 6" CEMENT STAB. AGGREGATE BASE MATERIAL TYPE 1, NO. 21A (4% HYDRAULIC CEMENT BY WEIGHT)
- 5 STABILIZE TOP 6" OF SUBGRADE WITH 12% HYDRAULIC CEMENT BY VOLUME
- 6 6" CEMENT STAB. AGGREGATE BASE MATERIAL TYPE 1, NO. 21A (4% HYDRAULIC CEMENT BY WEIGHT)
- 7 4" ASPHALT CONCRETE BASE COURSE TYPE BM-25
- 8 ASPHALT CONCRETE SURFACE COURSE TYPE SM-12.5D @ 220 LB/SY.

NOTE: WHEN LIQUID ASPHALT MATERIAL IS USED AS A CURING MATERIAL FOR A HYDRAULIC CEMENT OR LIME STABILIZED COURSE, IT SHALL BE LIQUID ASPHALT MATERIAL CRS-2L AND APPLIED AT THE RATE OF 0.3 GAL/SY, WHERE NECESSARY FOR MAINTENANCE OF CONSTRUCTION TRAFFIC. COVER MATERIALS 8P AGGREGATE SHALL BE APPLIED AT THE RATE OF 20 LBS/SY. ALL COSTS FOR SUCH CURING MATERIALS AND ANY COVER MATERIALS SHALL BE INCLUDED IN PRICE BID FOR THE HYDRAULIC CEMENT OR LIME STABILIZED COURSE.

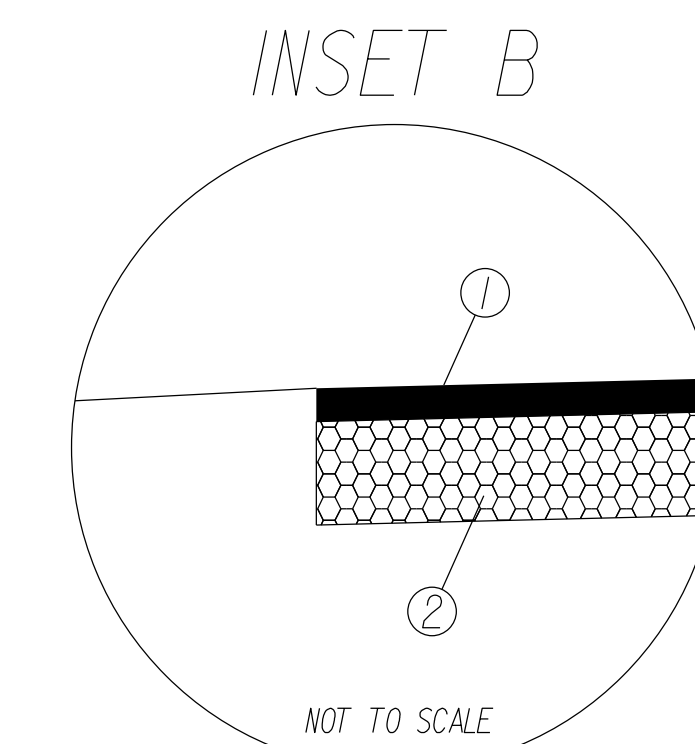

- 1 PRIME AND DOUBLE SEAL
- 2 8" AGGREGATE BASE MATERIAL, TYPE 1, NO. 21A

PLAN NO.	PROJECT	FILE NO.	SHEET NO.
	XXXX-XXX-XXX		2B

FIGURE 2H - 17 SAMPLE TYPICAL SECTION SHEET

8/27/2014
3:53:46 PM

Drainage Summary Sheet.dgn
Plotted By: stewartwills

PROJECT MANAGER: <Project_Mgr_Name (000) 000-0000 (District)> -----
SURVEYED BY, DATE: <Surveyor_Name (000) 000-0000 (District)> -----
DESIGN BY: <Designer_Name (000) 000-0000 (District)> -----
SUBSURFACE UTILITY BY, DATE: <Surveyor_Name (000) 000-0000 (District)>

REVISED	STATE	ROUTE	STATE PROJECT	SHEET NO.
	VA.	XXX	XXXX-XXX-XXX, C-50X	2C

DESIGN FEATURES RELATING TO CONSTRUCTION OR TO REGULATION AND CONTROL OF TRAFFIC MAY BE SUBJECT TO CHANGE AS DEEMED NECESSARY BY THE DEPARTMENT

DRAINAGE SUMMARY

PROJECT	LOCATION	CONCRETE PIPE						HDPE PIPE		JACKED PIPE		PIPE		END SECTIONS ES-1		DROP INLET DI-12 TYPE 1	CONCRETE AS CL/MSC. (INCLUDES ENDWALLS)	MINOR STRUCTURE EACH PIPE COUERT	BEDDING MATERIAL AGR. NO. 25 OR 26	MANHOLES		EROSION CONTROL STONE	BACKFILL MATERIAL		SEE NOTE(S)		
		COVER						60 in	60 in	18 in	30 in	36 in	L-4	CY	CY					TON	LF		EA	TON		CY	CY
		15 in	18 in	30 in	36 in	42 in	60 in																				
0095-96A-105, C-504	3-1	15					104									8.5	435	53.4			47.9	34.4	84.2	S'd. 60" EW-2 Req'd.			
	3-2	7							168															See Special Provisions			
	3-3	13.0					62									8.5	260	19.5			47.9	22.2	54.3	S'd. 60" EW-2 Req'd.			
	3-4	5.4					191											29.5			24.1	37.6	98.0				
	3-5																										
	3-5A	5.3					84											14.6				18.6	48.4				
	3-6																					9.9	1				
	3-6A	2.7	24																3.0				1.3	4.9	Connect To Exist. Pipe		
	3-7	6.5				116													35.4			18.0	21.7	58.5			
	3-8	5.5			75														16.0			12.5	8.1	25.5			
	3-9																										
	3-10																					9.3	1				
	3-11	7.0	6																				0.3	1.2			
	3-14	6.1	23																0.8				1.1	3.9	Connect To Exist. Pipe		
	3-15							64														1.0			Combered (12 Inches)		
	3-16							34														1.0			Combered (12 Inches)		
	3-17							43														1.0			Combered (12 Inches)		
	3-18	5.3	18																0.6				1.0	3.7	Connect To Exist. Pipe		
	3-20	4.1	10																1.4				0.6	2.3	Connect To Exist. Pipe		
	3-21							87														1.0			Combered (12 Inches)		
	3-22							92														1.0			Combered (12 Inches)		
	3-23	18.2								48									14.0			47.9	15.9	38.9	Temporary Pipe		
	SUBTOTAL SHEET 3		48	33	75	116	275	166	320		168	48	1	1	1	1	17	695	189	28.5	3	203.8	162.8	423.8			

ALLOWABLE PIPE TYPES (UNLESS OTHERWISE SHOWN ON PLANS) SEE STANDARD DRAWING PC-1 FOR HEIGHT OF COVER LIMITATIONS FOR EACH TYPE					
PIPE LOCATION	CONCRETE	UNCOATED CORRUGATED STEEL	CORRUGATED ALUMINUM ALLOY	POLYTHLENE CORRUGATED	HDPE
ALL ROADWAYS	X				
JACKED PIPE	X				
TEMPORARY DRAINAGE SYSTEM	X	X	X	X	X

⊗ DENOTES ITEMS TO BE PAID FOR ON BASIS OF PLAN QUANTITIES IN ACCORDANCE WITH CURRENT ROAD AND BRIDGE SPECIFICATIONS.

PROJECT	SHEET NO.
XXXX-XXX-XXX	2C

FIGURE 2H - 18 SAMPLE DRAINAGE SUMMARY SHEET

8/27/2014
4:07:35 PM

Roadside Development.dgn
Plotted By: stewartwills

SURVEYED BY _____
SUPERVISED BY _____
DESIGNED BY _____

DESIGN FEATURES RELATING TO CONSTRUCTION OR TO REGULATION AND CONTROL OF TRAFFIC MAY BE SUBJECT TO CHANGE AS DEEMED NECESSARY BY THE DEPARTMENT

REVISED	STATE	FEDERAL AID PROJECT	ROUTE	STATE PROJECT	SHEET NO.
	VA		XXX	XXXX-XXX-XXX, C-50X	2D

ROADSIDE DEVELOPMENT

CORE MIX

MIX	LBS./ACRES	DESCRIPTION
1	▲	* 100% CERTIFIED FINE FESCUE
2	▲	100% CERTIFIED TALL FESCUE
3	100	50% CERTIFIED TALL FESCUE * 50% CERTIFIED FINE FESCUE
4	▲	50% ORCHARDGRASS 50% CERTIFIED KENTUCKY BLUEGRASS
5	▲	100% BERMUDAGRASS
TEMPORARY		
3/1 - 5/16 and	50	50% CERTIFIED TALL FESCUE
8/16 - 3/1	50	50% BARLEY, WINTER RYE OR WINTER WHEAT
5/16 - 8/16	50	50% FOXTAIL MILLET
	50	50% CERTIFIED TALL FESCUE

ADDITIVES

TYPE	LBS./ACRES	DESCRIPTION
A	▲	100% LOVEGRASS
B	15	100% BARLEY, WINTER RYE OR WINTER WHEAT
C	10	100% FOXTAIL MILLET
D	▲	100% ANNUAL RYEGRASS
E	▲	100% CROWNVELTCH (LEGUME)
F	▲	100% SERICEA LESPEDEZA (LEGUME)
G	▲	100% BIRDSFOOT TREFLOIL (LEGUME)
H	▲	
I	▲	
J	▲	
K	▲	

- ▲ ALL RATES TO BE SPECIFIED BY THE DISTRICT ROADSIDE MANAGER
- * FINE FESCUES INCLUDE CHEWINGS, CREEPING RED, HARD, SHEEP

SECTION OF SEED LOCATIONS

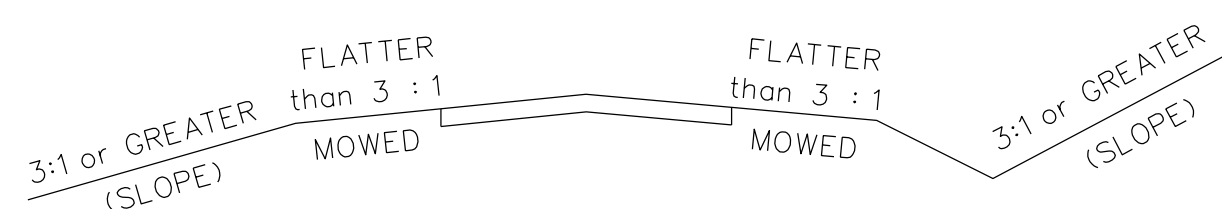

SEEDING SCHEDULE

ROADSIDE DEVELOPMENT SUMMARY									
PROJECT NUMBERS	TOPSOIL 2" CLASS		REGULAR SEED	OVER SEEDING	LIME	FERT. 10-10-10	LEGUME SEED	LEGUME OVER SEEDING	TEMPORARY SEEDING
	A	B							
	ACRES		LB	LB	TON	TON	LB	LB	LB
0729-078-182, C-501			307	192	6	1			

PROJECT NUMBERS	SLOPES SEED MIX WITH ADDITIVE	MOWED SEED MIX WITH ADDITIVE	SLOPES SEED MIX WITH ADDITIVE	MOWED SEED MIX WITH ADDITIVE	SLOPES SEED MIX WITH ADDITIVE	MOWED SEED MIX WITH ADDITIVE
	SPRING MONTH & DATE	SUMMER MONTH & DATE	FALL & WINTER MONTH & DATE			
0729-078-182, C-501	4/1 - 6/1	6/1 - 9/15	9/15 - 4/1	Core Mix *3 No Additive	Core Mix *3 Additive C	Core Mix *3 Additive B
* SPECIFY KIND OF FINE FESCUE	Any	Any	Any			

⊗ DENOTES ITEM(S) TO BE PAID FOR ON BASIS OF PLAN QUANTITIES IN ACCORDANCE WITH CURRENT ROAD AND BRIDGE SPECIFICATIONS.

Fertilizer: Do not use any fertilizer within fifty feet of an active stream or lake. No fertilizer may be applied anywhere between November 1 and March 15. Within these restrictions, apply 440 lbs./acre of 10-10-10 fertilizer at time of seeding. Lime is applied at 2,000 lbs./acre.

NOTES:

APPROXIMATELY 1.6 ACRES WILL BE DISTURBED ON THIS PROJECT AND WILL REQUIRE THE ESTABLISHMENT OF GRASSES AND/OR LEGUMES.

☆ NOTES FOR FIELD USE ONLY

OVERSEEDING RATES SHALL BE 100 PERCENT OF THE SEED MIXTURE SUPPLIED WITHOUT FERTILIZER.

THE ENGINEER WILL REQUIRE THE CONTRACTOR TO PERFORM SUPPLEMENTAL SEEDING WHEN LESS THAN 75 PERCENT UNIFORM STAND OF THE PERMANENT GRASS SPECIFIED IN THE MIXTURES IS OBTAINED. (ANNUAL SPECIES SUCH AS, RYE AND MILLET ARE TEMPORARY VARIETIES AND REQUIRE SUPPLEMENTAL SEEDING.)

NOTES APPLY TO SCHEDULE

LEGUME SEED MIXES (BIRDSFOOT TREFLOIL, CROWNVELTCH, AND SERICEA LESPEDEZA) AND WEEPING LOVEGRASS SHALL NOT BE USED ON SHOULDERS AND OTHER LOCATIONS FLATTER THAN 3:1 SLOPE.

LEGUME SEED SHALL BE INOCULATED WITH THE APPROPRIATE STRAIN AND RATE OF BACTERIA. FOR HYDROSEEDING, USE FIVE TIMES THE DRY SEEDING RATE OF INOCULATE.

A TEMPORARY MIX OR EROSION CONTROL MULCH, AS DIRECTED BY THE ENGINEER, IS TO BE USED ONLY ON AREAS THAT ARE TO BE REGRADED OR LATER DISTURBED, IF LEFT DORMANT FOR MORE THAN 15 DAYS.

EROSION CONTROL MULCH, AS DIRECTED BY THE ENGINEER, IS TO BE USED ON AREAS THAT ARE TO BE LEFT DORMANT FOR MORE THAN 15 DAYS BETWEEN DECEMBER 1 AND FEBRUARY 28.

EROSION CONTROL MULCH, AS LISTED ON THE VDOT APPROVED PRODUCTS LIST, SHALL BE APPLIED IN ACCORDANCE WITH THE MANUFACTURER'S RECOMMENDATIONS.

EROSION CONTROL MULCH SHALL PROVIDE 100 PERCENT COVERAGE OF ALL DENUDED AREAS

SPRING & SUMMER AND FALL & WINTER DEFINED FOR THE PURPOSE OF DETERMINING WHETHER HULLED OR UNHULLED BERMUDAGRASS AND SERICEA LESPEDEZA SEED IS REQUIRED:

SPRING & SUMMER 4/1 - 9/15 - USE HULLED SEED
FALL & WINTER 9/15 - 4/1 - USE UNHULLED SEED

TYPE I MULCH (STRAW) TO BE USED ON NEWLY SEEDED AREAS ADJACENT TO ALL WATERWAYS, WETLANDS, SWAMPS, OR ANY AREA IN WHICH DRAINAGE FLOWS TOWARD AREAS UNDER THE JURISDICTION OF THE ENVIRONMENTAL REGULATORY AGENCIES.

TYPE I MULCH SHALL BE APPLIED TO PROVIDE A MINIMUM 90 PERCENT COVERAGE.

TYPE I MULCH SHALL BE TACKED WITH FIBER MULCH AT THE RATE OF 500 LBS. PER ACRE AND/OR MULCH TACKIFIER.

TYPE II MULCH (FIBER MULCH) MAY BE SUBSTITUTED FOR TYPE I MULCH AT THE RECOMMENDATION OF THE DISTRICT ROADSIDE MANAGER.

TYPE II MULCH SHALL BE APPLIED AT A RATE OF 1000 LBS. (NET DRY WEIGHT) PER ACRE TO PROVIDE A MINIMUM OF 90 PERCENT COVERAGE, AND SHALL BE APPLIED IN A SEPARATE APPLICATION.

ALL TOPSOIL IS TO BE FREE OF HARD LUMPS, CLOUDS, ROCKS AND FOREIGN DEBRIS AND IS TO BE HAND RAKED TO TIE INTO EXISTING LAWNS.

ALL SEED MUST BE IN CONFORMANCE WITH VDOT SEED SPECIFICATIONS FOR GRASSES & LEGUMES AND BE PROVIDED AT THE PROJECT SITE IN BAGS NOT OPENED AND LABELED FOR USE ON VDOT PROJECTS WITH A GREEN TAG CERTIFYING INSPECTION BY THE VIRGINIA CROP IMPROVEMENT ASSOCIATION.

MIX REQUIREMENTS THIS PROJECT

RECOMMENDATIONS FOR THE APPLICATION OF SEED MIXTURES (CORE MIX AND ADDITIVES), FERTILIZER, LIME, ETC. ARE TO BE OBTAINED FROM THE DISTRICT ROADSIDE MANAGER.

PLAN NO.	PROJECT	FILE NO.	SHEET NO.
	XXXX-XXX-XXX		2D

FIGURE 2H - 19 SAMPLE ROADSIDE DEVELOPMENT SHEET

9/2/2014
9:32:33 AM

Stormwater Management Summary Sheet.dgn
Plotted By: stewartwillis

PROJECT MANAGER (Project Name: 0000-0000-0000, District) -----
SURVEYED BY, DATE (Surveyor Name: 0000-0000-0000, District) -----
DESIGN BY (Designer Name: 0000-0000-0000, District) -----
SUBSURFACE UTILITY BY, DATE (Surveyor Name: 0000-0000-0000, District) -----

STORMWATER POLLUTION PREVENTION PLAN (SWPPP)
GENERAL INFORMATION SHEET

The information contained in the SWPPP General Information sheets is intended to comply with the requirements of the VSMP General Permit For Discharges Of Stormwater From Construction Activities (the VSMP Construction Permit) issued July 1, 2009 and VDOT's approved Annual ESC and SWM Standards and Specifications.

The SWPPP General Information sheets are to be completed and included in the construction plan set (or other such documents) for land disturbance activities that disturb an area equal to or greater than 10,000 square feet, or equal to or greater than 2,500 square feet in the area defined as Tidewater, Virginia in the Virginia Chesapeake Bay Preservation Act.

Information shown on the SWPPP General Information sheets is to be updated/ revised by the VDOT RLD as necessary in order to reflect changes that may occur during the construction phase of the land disturbing activity. The updated/ revised sheets shall be maintained with the designated record set of plans for the land disturbance activity.

X Denotes information that is to be provided/ completed by the VDOT RLD.
XX Denotes information that is to be provided/ completed by the contractor.

Note: Effective July 1, 2013, responsibility for the VSMP General Permit For Discharges Of Stormwater From Construction Activities (the VSMP Construction Permit) was transferred from the DCR to the DEQ.

REVISED	STATE	ROUTE	STATE PROJECT	SHEET NO.
	VA	00	0000-000-000, RW-000 C-000	

DESIGN FEATURES RELATING TO CONSTRUCTION OR TO REGULATION AND CONTROL OF TRAFFIC MAY BE SUBJECT TO CHANGE AS DEEMED NECESSARY BY THE DEPARTMENT

SECTION I GENERAL INFORMATION

- Activity Description - (insert appropriate text)
- This land disturbance activity site is located in (insert the appropriate County/City) and approximately (insert the appropriate number to the nearest one tenth acre) acres will be disturbed by excavation, grading or other construction activities.
- (Include one of the following notes as appropriate)
This proposed activity disturbs one acre or greater (2,500 square feet or greater in a designated Chesapeake Bay Preservation Area) and requires coverage under the VSMP General Permit For Discharges Of Stormwater From Construction Activities (the VSMP Construction Permit) as issued by the DEQ.

This proposed activity disturbs less than one acre (less than 2,500 square feet in a designated Chesapeake Bay Preservation Area) and is exempt from the VSMP Regulations and coverage under the VSMP General Permit For Discharges Of Stormwater From Construction Activities (the VSMP Construction Permit) as issued by the DEQ.

This proposed activity is exempt from the VSMP Regulations and coverage under the VSMP General Permit For Discharges Of Stormwater From Construction Activities (the VSMP Construction Permit) as issued by the DEQ because it is considered a routine maintenance activity (i.e., the proposed activity is intended to maintain the original line and grade, hydraulic capacity or original construction of the project or involves the paving of an existing roadway with a compacted or impervious surface and the reestablishment of existing associated ditches and shoulders).
- The ESC and SWM plans (where applicable) for this land disturbance activity have been developed in accordance with VDOT's Annual Erosion and Sediment Control and Stormwater Management Standards and Specifications as approved by the DEQ.
- (Insert VDOT person's name and job title) is designated as the RLD for this land disturbance activity.
- Critical areas (e.g., wetlands, surface water bodies, etc) adjacent to this land disturbance activity site and not otherwise identified in the construction plan set (or other such documents) are as follows: (insert appropriate text)
- Stormwater run-off from the disturbed areas of this land disturbance activity will flow into the following streams: (insert appropriate stream names; for any unnamed tributary, identify what named stream it flows into, e.g., Unnamed Tributary to Bull Run)
- Locations where stormwater discharges from this land disturbance activity site to a surface water (as defined in section 4VAC50-60-10 of the VSMP Regulations) are identified in the construction plan set (or other such documents).

SECTION II EROSION AND SEDIMENT CONTROL

- The following variances to the Virginia ESC Regulations have been approved by the DEQ for this land disturbance activity: (list all approved variances: include a brief description of the variance, the date approved and the approving DEQ Office)
- XX 2. The intended sequence and timing of activities that disturb soils at the site (e.g., grubbing, excavation, grading, utilities and infrastructure installation, etc.) shall be provided by the contractor in accordance with Section 108.03 of the VDOT R&B Specifications and will be included with the other SWPPP documents for this land disturbance activity.
- Directions of stormwater flow and approximate slopes anticipated after major grading activities are identified in the construction plan set (or other such documents) for this land disturbance activity.
- Areas of soil disturbance and areas of the site which will not be disturbed are identified in the construction plan set (or other such documents) for this land disturbance activity.
- Locations of major structural and nonstructural ESC measures identified in the SWPPP, including those that will be permanent controls that will remain after construction activities have been completed, are identified in the construction plan set (or other such documents) for this land disturbance activity.
- Locations where stabilization practices are expected to occur are identified in the construction plan set (or other such documents) for this land disturbance activity.
- A description of interim and permanent stabilization practices for the site are identified in the applicable sections of the documents identified in the Note 1 of Section III.
- XX 8. A record of the dates when major grading activities occur, when construction activities temporarily or permanently cease on a portion of the site, and when stabilization measures are initiated will be provided by the contractor and maintained with the SWPPP documents for this land disturbance activity.
- A description of structural practices to divert flows from exposed soils, retain/detain flows or otherwise limit runoff and the discharge of pollutants from exposed areas of the construction site are identified in the applicable sections of the documents identified in Note 1 of Section III.
- A description and schedule of procedures to maintain vegetation, erosion and sediment control measures and other protective measures in good and effective operating conditions during construction are identified in Sections 107.16 and 303.03 of the VDOT R&B Specifications.
- All engineering calculations supporting the design of erosion and sediment control measures are contained in the project drainage file located in the (insert appropriate location, i.e., VDOT Central Office Hydraulics Section or the VDOT (specify) District Hydraulics Section or the VDOT (specify) Residency Office) and will be made available for review upon request during normal working business hours.

- The temporary erosion and siltation control items shown on the ESC Plan for this land disturbing activity are intended to provide a general plan for controlling erosion and sediment within the project limits. The ESC Plan is based on field conditions at the time of plan development and an assumed sequence of construction for the project. The contractor, in conjunction with the VDOT Project Engineer and/or ESC Inspector, shall adjust the location, quantity and type of erosion and sediment control items required based on the actual field conditions encountered at the time of construction and the actual scheduling and sequencing of the construction activities. Significant changes to the proposed ESC Plan (e.g., those that require an engineering analysis) shall be submitted to the applicable District Hydraulics Engineer for review and approval. Any changes to the proposed ESC Plan must be noted on the designated record set of plans which shall be retained on the project site and made available upon request during normal working business hours.
- The areas beyond the project's construction area are to be protected from siltation. Perimeter controls such as filter barrier, silt fence, diversion dikes, turbidity curtains, etc. shall be installed prior to any grubbing operations or other earth moving activities.
- Temporary earthen structures such as dikes and berms are to be stabilized immediately upon installation. Stabilization may include temporary or permanent seeding, riprap, aggregate, sod, mulching, and/or soil stabilization blankets and matting in conjunction with seeding.
- All channel relocations are to be constructed during the earliest stage of construction and shall be constructed in accordance with all applicable permit requirements and shall be constructed in the dry wherever possible. Stabilization or vegetation shall be established before flow is redirected through the constructed area as directed by the Engineer.

- ACRONYMS
- DCR - Department of Conservation and Recreation
 - DEQ - Department of Environmental Quality
 - EPA - U.S. Environmental Protection Agency
 - ESC - Erosion and Sediment Control
 - R&B - Road and Bridge
 - RLD - Responsible Land Disturber
 - SWM - Stormwater Management
 - SWPPP - Stormwater Pollution Prevention Plan
 - VDOT - Virginia Department of Transportation
 - VSMP - Virginia Stormwater Management Program

Revised 8/8/13
Sheet 1 of 3

PROJECT	SHEET NO.
0000-000-000	2E(1)

9/2/2014
9:33:45 AM

Stormwater Management Summary Sheet.dgn
Plotted By: stewartw@vdot.gov

PROJECT MANAGER: <Project_Mgr_Name (000) 000-0000 (01strctd)> -----
SURVEYED BY, DATE: <Surveyor_Name (000) 000-0000 (01strctd)> -----
DESIGN BY: <Designer_Name (000) 000-0000 (01strctd)> -----
SUBSURFACE UTILITY BY, DATE: <Surveyor_Name (000) 000-0000 (01strctd)>

STORMWATER POLLUTION PREVENTION PLAN (SWPPP)
GENERAL INFORMATION SHEET

REVISED	STATE		PROJECT	SHEET NO.
	STATE	ROUTE		
	VA.	00	0000-000-000, RW-000 C-000	2E(2)

DESIGN FEATURES RELATING TO CONSTRUCTION OR TO REGULATION AND CONTROL OF TRAFFIC MAY BE SUBJECT TO CHANGE AS DEEMED NECESSARY BY THE DEPARTMENT

The information contained in the SWPPP General Information sheets is intended to comply with the requirements of the VSMP General Permit For Discharges Of Stormwater From Construction Activities (the VSMP Construction Permit) issued July 1, 2009 and VDOT's approved Annual ESC and SWM Standards and Specifications.

Information shown on the SWPPP General Information sheets is to be updated/revised by the VDOT RLD as necessary in order to reflect changes that may occur during the construction phase of the land disturbing activity. The updated/revised sheets shall be maintained with the designated record set of plans for the land disturbance activity.

The SWPPP General Information sheets are to be completed and included in the construction plan set (or other such documents) for land disturbance activities that disturb an area equal to or greater than 10,000 square feet, or equal to or greater than 2,500 square feet in the area defined as Tidewater, Virginia in the Virginia Chesapeake Bay Preservation Act.

* Denotes information that is to be provided/completed by the VDOT RLD.
** Denotes information that is to be provided/completed by the contractor.

Note: Effective July 1, 2013, responsibility for the VSMP General Permit For Discharges Of Stormwater From Construction Activities (the VSMP Construction Permit) was transferred from the DCR to the DEQ.

SECTION III SWPPP

1. All documents related to the SWPPP for this land disturbance activity shall be maintained at the activity site and shall be readily available for review upon request during normal working business hours. Such documents include, but are not limited to, the construction plans (or other such documents), the ESC Plan, the post construction SWM Plan (if applicable), the VDOT R&B Standards and Specifications, Supplemental Specifications, Special Provisions and Special Provision Copied Notes. Documents related to stormwater pollution prevention which are not a part of those documents referenced above, such as a copies of the VSMP Construction Permit coverage letter (when applicable) and the DCR General Permit For Discharges Of Stormwater From Construction Activities (when applicable) and those required to be developed by the contractor for stormwater pollution prevention associated with any support facilities being included in the VSMP Construction Permit coverage for this land disturbance activity are to be maintained at the activity site with the other SWPPP documents. Where no facilities are available at the activity site to maintain the SWPPP documents, they are to be kept by or with the designated RLD at a location convenient to the activity site where they would be made available for review upon request during normal business working hours.

2. Other than construction at the activity site, there are no discharges associated with industrial activity (e.g., from dedicated asphalt plants or dedicated concrete plants) produced by this land disturbance activity or (where applicable) included in the VSMP Construction Permit coverage for this land disturbance activity.

XX 3. Documents identifying the locations of support facilities (e.g., waste or borrow areas, material or equipment storage areas etc.) associated with or (where applicable) included in the VSMP Construction Permit coverage for this land disturbance activity shall be provided by the contractor in accordance with Section 107.16 of the VDOT R&B Specifications and will be maintained with the other SWPPP documents for this land disturbance activity.

XX 4. A description of all pollution control measures that will be implemented as a part of this construction activity to control pollutants in stormwater discharges are identified and described in the contractor supplied documents, the construction plan set (or other such documents) and applicable sections of the VDOT R&B Specifications and Standards, including but not limited to, Specifications 107.16, 303.03, 603, 604 and 606 and Standards 113.01 through 114.08.

XX 5. The name of the individual(s) or contractor(s) responsible for the installation and maintenance of the pollution control measures shall be supplied by the contractor and maintained with the other SWPPP documents for this land disturbance activity.

6. Requirements for the prevention of the discharge of solid materials, including building materials, garbage, and debris, to surface waters of the state, except as authorized by a Clean Water Act 404 permit, are contained in Sections 106.04, 107.02 and 107.16 of the VDOT R&B Specifications.

7. Requirements for compliance with applicable state or local waste disposal, sanitary sewer or septic system regulations are contained in Sections 106.04 and 107.18 of the VDOT R&B Specifications.

XX 8. A description of construction and waste materials expected to be stored on-site, or at off-site support facilities included in the VSMP Construction Permit coverage for this land disturbance activity, and a description of controls to reduce pollutants from these materials, including storage practices to minimize exposure of the materials to stormwater and practices for spill prevention and response, shall be supplied by the contractor and maintained with the other SWPPP documents for this land disturbance activity.

XX 9. For any support areas that will be included in the VSMP Construction Permit coverage for this land disturbance activity, a description of potential pollutant sources from such areas and a description of controls and measures that will be implemented at those sites to minimize pollutant discharges shall be supplied by the contractor and maintained with the other SWPPP documents for this land disturbance activity.

X 10. By completing and submitting the SWPPP Certification form LD-445E, the RLD, or his authorized representative, certifies that all documents identified herein to be supplied by the contractor will be reviewed, approved and included with the other SWPPP documents for this land disturbance activity prior to start of work in those areas identified by such information.

X 11. The name of the VDOT individual(s) responsible for the inspection of the erosion and sediment control measures on the land disturbance activity is identified on the LD-445E form which will be maintained with the other SWPPP documents for this land disturbance activity (Note: Individual(s) shall be certified through the DCR ESC Inspector Certification Program).

12. For those land disturbing activities requiring coverage under the VSMP General Permit For The Discharge Of Stormwater From Construction Activities, the SWPPP shall be made available for review upon the request of the DCR, the EPA, local government officials or the operator of a municipal separate storm sewer system (MS4) receiving discharge from the construction site.

X 13. For those land disturbing activities requiring coverage under the VSMP General Permit For The Discharge Of Stormwater From Construction Activities, the VDOT RLD shall post, or have posted, a copy of the General Permit coverage letter and a copy of a completed LD-445A form, noting the name and contact information for the VDOT person responsible for the land disturbing activity and its SWPPP, outside the project's construction office along with other Federal and State mandated information. Where there is no construction office (e.g., a maintenance activity), the permit coverage letter and the LD-445A form are to be maintained with the other SWPPP documents for the land disturbing activity.

14. For those land disturbing activities requiring coverage under the VSMP General Permit For The Discharge Of Stormwater From Construction Activities on or after July 1, 2009 that have not been previously covered by a VSMP permit, the SWPPP shall be made available for review by the public upon request. Such reviews shall be at a time and publicly accessible location convenient to the VDOT and shall be scheduled during normal business hours and no less than once a month.

SECTION IV POST CONSTRUCTION STORMWATER MANAGEMENT

Choose the appropriate note(s) 1 through 7 that are applicable to the proposed post construction SWM Plan for this land disturbance activity. Delete, strikethrough or mark as NA those not applicable.)

1. This land disturbance activity does not require permanent water quality SWM facilities because the post development percent impervious of the site is less than 16%.

2. The following outfalls do not require a permanent water quality SWM facility because the post development percent impervious of the site draining to each noted outfall is less than 16%. (List all applicable locations)

3. This land disturbing activity is designated a Category 2 project and complies with post development water quality requirements in accordance with the provisions of the VDOT Stormwater Program Advisory SWPA 12-01.

4. This land disturbing activity complies with post development water quality requirements in accordance with the provisions of the VDOT Stormwater Program Advisory SWPA 12-02.

5. An exception for (number) pounds of phosphorus removal has been granted by the DEQ in its letter dated (date).

6. This land disturbance activity is grandfathered under the Part IIC (old) technical criteria (i.e., Performance or Technology Based, MS 19, etc.) in Section 4VAC50-60-93.1 et seq. of the VSMP Regulations.

7. This land disturbance activity utilizes the Part IIB (new) technical criteria (i.e., Runoff Reduction Method, Energy Balance Equation, etc.) in Section 4VAC50-60-62 et seq. of the VSMP Regulations.

8. The permanent SWM facilities proposed to meet the water quality/quantity requirements for this land disturbance activity are listed in Section VI. (List each location and the type of proposed permanent SWM facility, including any agreements for the use of offsite or regional stormwater facilities, payment into DCR approved County/City Watershed Stormwater Management Plan fund or purchase of nutrient credits).

9. A description of all post-construction stormwater management measures that will be installed during the construction process to control pollutants in stormwater discharges after construction operations have been completed is included in the construction plan set (or other such documents) for this land disturbance activity.

10. All engineering calculations supporting the design of the post-construction stormwater management measures, including an explanation of the technical basis used to select the practices, are contained in the project drainage file located in the (insert appropriate location, i.e., VDOT Central Office Hydraulics Section or the VDOT (specify) District Hydraulics Section or the VDOT (specify) Residency Office) and will be made available for review upon request during normal working business hours.

ACRONYMS

- DCR - Department of Conservation and Recreation
- DEQ - Department of Environmental Quality
- EPA - U.S. Environmental Protection Agency
- ESC - Erosion and Sediment Control
- R&B - Road and Bridge
- RLD - Responsible Land Disturber
- SWM - Stormwater Management
- SWPPP - Stormwater Pollution Prevention Plan
- VDOT - Virginia Department of Transportation
- VSMP - Virginia Stormwater Management Program

Revised 6/25/13
Sheet 2 of 3

PROJECT	SHEET NO.
0000-000-000	2E(2)

9/2/2014
9:33:58 AM

Stormwater Management Summary Sheet.dgn
Plotted By: stewartwills

PROJECT MANAGER <Project_Mgr_Name (0000) 000-0000 (District)> -----
SURVEYED BY, DATE <Surveyor_Name (0000) 000-0000 (District)> -----
DESIGN BY <Designer_Name (0000) 000-0000 (District)> -----
SUBSURFACE UTILITY BY, DATE <Surveyor_Name (0000) 000-0000 (District)> -----

STORMWATER POLLUTION PREVENTION PLAN (SWPPP)
GENERAL INFORMATION SHEET

REVISED	STATE	ROUTE	STATE PROJECT	SHEET NO.
	VA.	00	0000-000-000, RW-000 C-000	2E(3)

The information contained in the SWPPP General Information sheets is intended to comply with the requirements of the VSMP General Permit For Discharges Of Stormwater From Construction Activities (the VSMP Construction Permit) issued July 1, 2009 and VDOT's approved Annual ESC and SWM Standards and Specifications.

Information shown on the SWPPP General Information sheets is to be updated/revised by the VDOT RLD as necessary in order to reflect changes that may occur during the construction phase of the land disturbing activity. The updated/revised sheets shall be maintained with the designated record set of plans for the land disturbance activity.

The SWPPP General Information sheets are to be completed and included in the construction plan set (or other such documents) for land disturbance activities that disturb an area equal to or greater than 10,000 square feet, or equal to or greater than 2,500 square feet in the area defined as Tidewater, Virginia in the Virginia Chesapeake Bay Preservation Act.

* Denotes information that is to be provided/completed by the VDOT RLD.
** Denotes information that is to be provided/completed by the contractor.

Note: Effective July 1, 2013, responsibility for the VSMP General Permit For Discharges Of Stormwater From Construction Activities (the VSMP Construction Permit) was transferred from the DCR to the DEQ.

DESIGN FEATURES RELATING TO CONSTRUCTION OR TO REGULATION AND CONTROL OF TRAFFIC MAY BE SUBJECT TO CHANGE AS DEEMED NECESSARY BY THE DEPARTMENT

SECTION V - LOCATION MAP

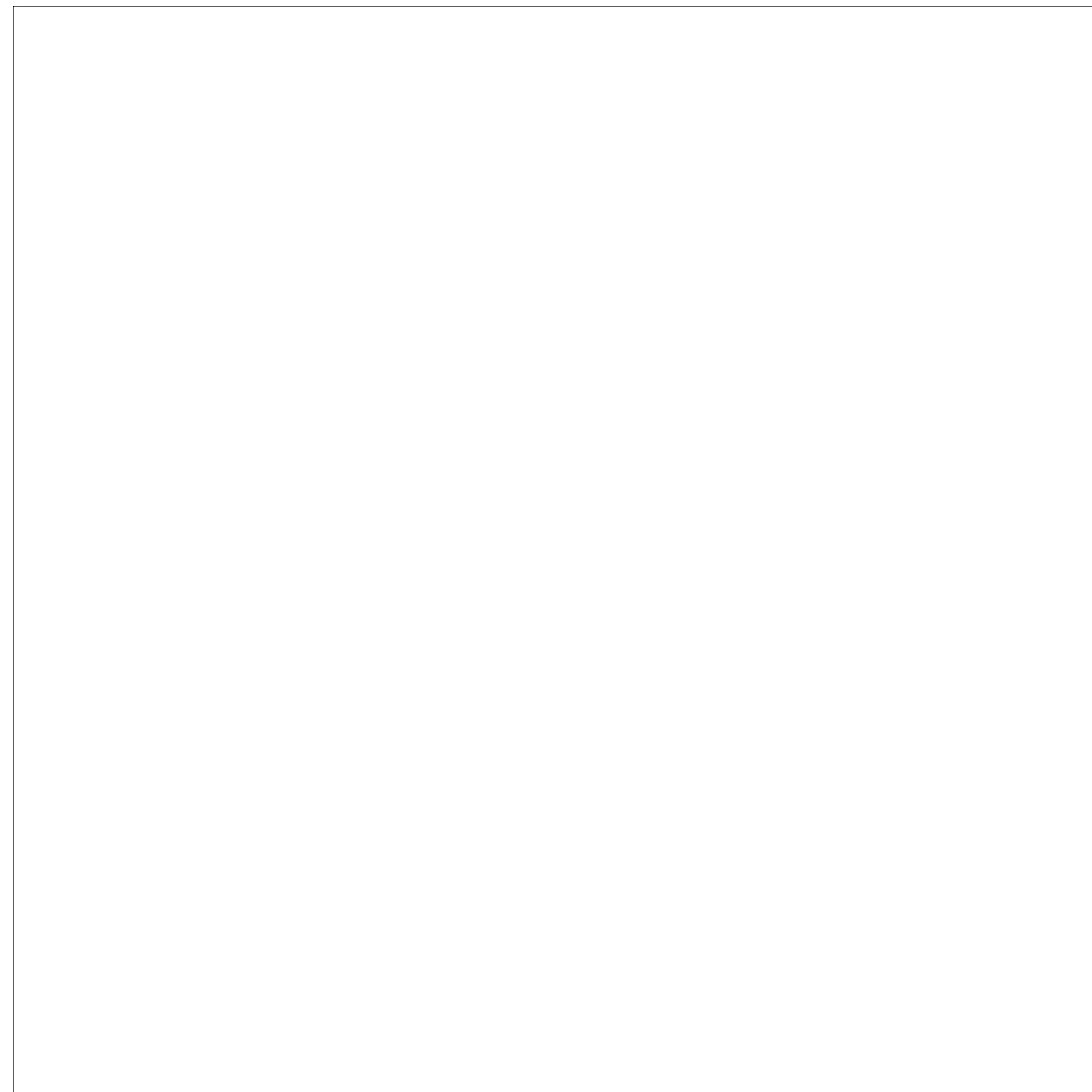

SECTION VI - PERMANENT BMP INFORMATION Δ

INSTALLED BMP INFORMATION
Table A
(VDOT Owned/Operated)

BMP Type (See Table 1)	County or City	Latitude/Longitude (1)		State Hydrologic Unit Code (7)	Receiving Stream Name (2)	Acres Treated Per BMP (3)	
		LAT	LONG			Impervious	Pervious

ALTERNATIVE BMP INFORMATION
Table B

BMP Type (See Table 2)	Name of Nutrient Bank or Broker (6)	County or City (5)	Latitude/Longitude (1) (5)		State Hydrologic Unit Code (5) (7)	Project Acres Treated Per BMP (3)		Nutrient Credits (lbs./acre/year) Acquired (3) (6)
			LAT	LONG		Impervious	Pervious	

- ACRONYMS
- DCR - Department of Conservation and Recreation
 - DEQ - Department of Environmental Quality
 - EPA - U.S. Environmental Protection Agency
 - ESC - Erosion and Sediment Control
 - R&B - Road and Bridge
 - RLD - Responsible Land Disturber
 - SWM - Stormwater Management
 - SWPPP - Stormwater Pollution Prevention Plan
 - VDOT - Virginia Department of Transportation
 - VSMP - Virginia Stormwater Management Program

- Table 1: Permanent BMP Types
- Bio-Retention Basin
 - Bio-Retention Filter
 - Constructed Stormwater Wetlands
 - Extended Detention Basin
 - Extended Detention Basin Enhanced
 - Grassed Swale
 - Infiltration Basin
 - Infiltration Trench
 - Manufactured Treatment Device
 - Retention Basin I
 - Retention Basin II
 - Retention Basin III
 - Sand Filter
 - Vegetated Filter Strip
 - Other Approved Types (List Type)

Δ The information shown in the BMP tables is based on the proposed pre-construction SWM Plan. Any changes to the proposed SWM Plan or BMPs necessitated during the construction phase of the project shall be coordinated by the VDOT RLD with the appropriate VDOT District Hydraulics Engineer. The RLD is to have the information in the BMP tables and plans formally revised to reflect any authorized/approved changes to the proposed SWM Plan and BMPs. Prior to submitting for termination of coverage under the VSMP General Permit For The Discharge Of Stormwater From Construction Activities, the RLD shall have the District Maintenance Infrastructure Manager review the BMPs installed with the project (Table A) for acceptance of maintenance responsibility and obtain a Maintenance ID number for each BMP listed in Table A. The RLD shall use the information in Tables A and B along with the assigned Maintenance ID number and the date that the BMP became functional as a permanent control measure (for BMPs in Table A only) to complete the LD-445D form when submitting for termination of coverage under the VSMP General Permit For The Discharge Of Stormwater From Construction Activities.

- NOTES:
- (1) In degrees, minutes and seconds to the nearest 15 seconds.
 - (2) For streams with no names, list "Unnamed Tributary to (closest stream name)".
 - (3) Show acres treated or pounds purchased to the nearest one tenth.
 - (4) Include agreements with off-site BMP owners.
 - (5) Information pertains to the alternative BMP option location, where applicable.
 - (6) Applies to the purchase on nutrient credits only.
 - (7) 4th Order for Nutrient Credit Banks and 6th order for all other BMP types.

- Table 2: Alternative BMP Types
- Comprehensive SWM Plan (Regional) Facility
 - Pollutant Loading Pro Rata Share Program
 - Purchase of Nutrients Credits
 - Other Approved Options (List Type) (4)

Revised 6/25/13
Sheet 3 of 3

PROJECT	SHEET NO.
0000-000-000	2E(3)

FIGURE 2H - 22 SAMPLE STORMWATER POLLUTION PREVENTION PLAN SHEET 3 OF 3

9/2/2014
9:34:51 AM

Stormwater Management Summary Sheet.dgn
Plotted By: stewart.williams

PROJECT MANAGER (Project_Mgr_Name (000) 000-0000 (District)) -----
SURVEYED BY, DATE (Surveyor_Name (000) 000-0000 (District)) -----
DESIGN BY (Designer_Name (000) 000-0000 (District)) -----
SUBSURFACE UTILITY BY, DATE (Surveyor_Name (000) 000-0000 (District)) -----

REVISED	STATE	ROUTE	STATE	PROJECT	SHEET NO.
	VA.			XXXX-XXX-XXX, C-50X	2E(4)

DESIGN FEATURES RELATING TO CONSTRUCTION OR TO REGULATION AND CONTROL OF TRAFFIC MAY BE SUBJECT TO CHANGE AS DEEMED NECESSARY BY THE DEPARTMENT

STORMWATER MANAGEMENT SUMMARY

SWM Structure Number	Location	Stormwater Management Basin Excavation		6" Pipe Underdrain L.F.	Bioretention Soil Mixture C.Y.	No. 57 Stone TON	No. 7 Aggregate TON	Gabions C.Y.	Dry Riprap Class I 18" TON	Geotextile Fabric S.Y.
		Fill C.Y.	Cut C.Y.							
		6-3 (Bioretention Basin)	27+75 LT							
TOTAL		75	2462	168	131	13	5	18	7	234

	PROJECT XXXX-XXX-XXX	SHEET NO. 2E(4)
--	-------------------------	--------------------

Cell Revised 12/11/12

FIGURE 2H - 23 SAMPLE STORMWATER MANAGEMENT SUMMARY SHEET

9/2/2014
8:34:5 AM

Pavement Summary Sheet.dgn
Plotted By: stewartwillis

SURVEYED BY _____
SUPERVISED BY _____
DESIGNED BY _____

DESIGN FEATURES RELATING TO CONSTRUCTION OR TO REGULATION AND CONTROL OF TRAFFIC MAY BE SUBJECT TO CHANGE AS DEEMED NECESSARY BY THE DEPARTMENT

REVISED	STATE	FEDERAL AID PROJECT	ROUTE	STATE PROJECT	SHEET NO.
	VA.		XXX	XXXX-XXX-XXX, RW-20X C-50X	2F

PAVEMENT SUMMARY

LOCATION	STATION TO STATION		PAVEMENT AREA	Surface	Intermediate	Base	Base	Drainage Layer	Subbase				Select Aggregate Material CBR-30	Milling & Resurfacing		Temporary Pavement				
				Asphalt Conc. Type	Asphalt Conc. Type	Asphalt Conc. Type	Asphalt Conc. Type	3" Stabilized Open Graded Material	Aggregate Material No.	6" Aggregate Base Material Type I	6" Aggregate Base Material Type I	Hydraulic Cement 4% by Weight		FLEXIBLE PAVEMENT PLANING	Asphalt Conc. Type	Asphalt Conc. Type	Asphalt Conc. Type	Aggregate Base Material Type I	Asphalt Conc. Type	Asphalt Conc. Type
				SM-9.5D @ 175 lbs/sy	IM-19.0 A @ 240 lbs/sy	BM-25.0A 9" Depth	BM-25.0A 11" Depth		25 or 26	Size No. 21A	Size No. 21B	⊗		1 in / sy	IM-19.0 A @ 3" 360 lbs/sy	SM-9.5D @ 175 lbs/sy	BM-25.0A @ 240 lbs/sy	Type I Size 21B @ 6"	SM-9.5D @ 2 ton/cy	IM-19.0 A @ 2 ton/cy
FROM	TO	SF	TON	TON	TON	TON	TON	TON	TON	TON	TON	TON	SY	TON	TON	TON	TON	TON	TON	
MAINLINE RTE. 28	490+00	527+66.37	284,077	2,762	3,788	15,624		5,749		11,647			468							
MAINLINE RTE. 28 Widening	485+00	490+00	8,593	84	115		578				357									
Rte. 28 Milling & Resurfacing	485+64.56	490+00	22,827	233										5,073	457					
Golf Academy Drive	20+00	20+77.23	1,953	19										326						
Piper Lane	10+38.13	11+25	3,917	38	52	215		79			163									
Hornbaker Road	10+38.16	10+90	4,504	44							10			750						
Chapel Springs	10+00	10+36.80	532	5																
Temporary Pavement			550													6	8	22		
Entrances									47											
Asphalt ramps on Bridge & at Begin of Project																			28	18
Maintain Entrances									300											
TOTAL			326,953	3,185	3,955	15,839	578	5,828	347	11,647	530	⊗ 468	8,671	6,149	457	6	8	22	28	18

⊗ DENOTES : ITEMS TO BE PAID FOR ON BASIS OF PLAN QUANTITIES IN ACCORDANCE WITH CURRENT ROAD AND BRIDGE SPECIFICATIONS.

PLAN NO.	PROJECT	FILE NO.	SHEET NO.
	XXXX-XXX-XXX		2F

FIGURE 2H - 24 SAMPLE PAVEMENT SUMMARY SHEET

9/2/2014
8:54:21 AM

Grading Summary.dgn
Plotted By: stewartwillis

PROJECT MANAGER _____
SURVEYED BY _____
DESIGN SUPERVISED BY _____
DESIGNED BY _____

GRADING DIAGRAM AND SUMMARY

REVISED	STATE		SHEET NO.
	ROUTE	PROJECT	
	VA.	XXX XXXX-XXX-XXX, C-50X	2G

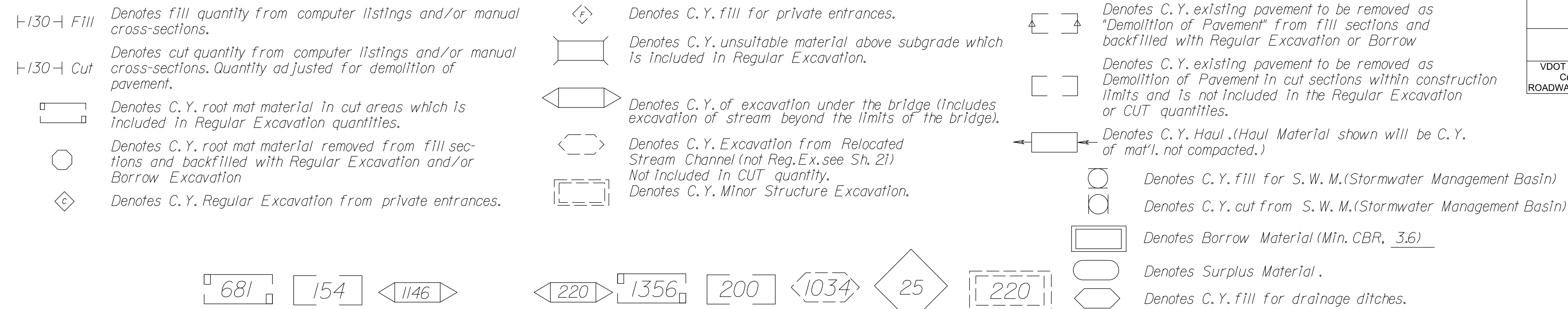

- DESIGN FEATURES RELATING TO CONSTRUCTION OR TO REGULATION AND CONTROL OF TRAFFIC MAY BE SUBJECT TO CHANGE AS DEEMED NECESSARY BY THE DEPARTMENT
- ⊗ Denotes items to be paid for on a basis of plan quantities in accordance with current VDOT Road and Bridge Specifications.
 - ① Cut quantity shown does not include the material removed as Demolition of Pavement.
 - ② Quantity shown for use in Grading Diagram only. See other Summaries for pay item(s).
 - ③ Included in Total Regular Excavation.
 - ④ Included in Roadway Cut quantity.
 - ⑤ Quantities for Temporary Sediment Basins and Temporary Sediment Traps are included with the Stormwater Management Basin quantities.
 - ⑥ Denotes pay item.
 - ⑦ Included in total fill quantity.
 - ⑧ This quantity comes from the computer listings and/or manual cross-sections and may be adjusted for other quantities.
 - ⑨ Volumes obtained for Cut Ditches and Fill Ditches not included in computer listings.
 - ⑩ Includes settlement of in-place soil.

VDOT Location and Design
Culpeper, Virginia
ROADWAY DESIGN ENGINEER

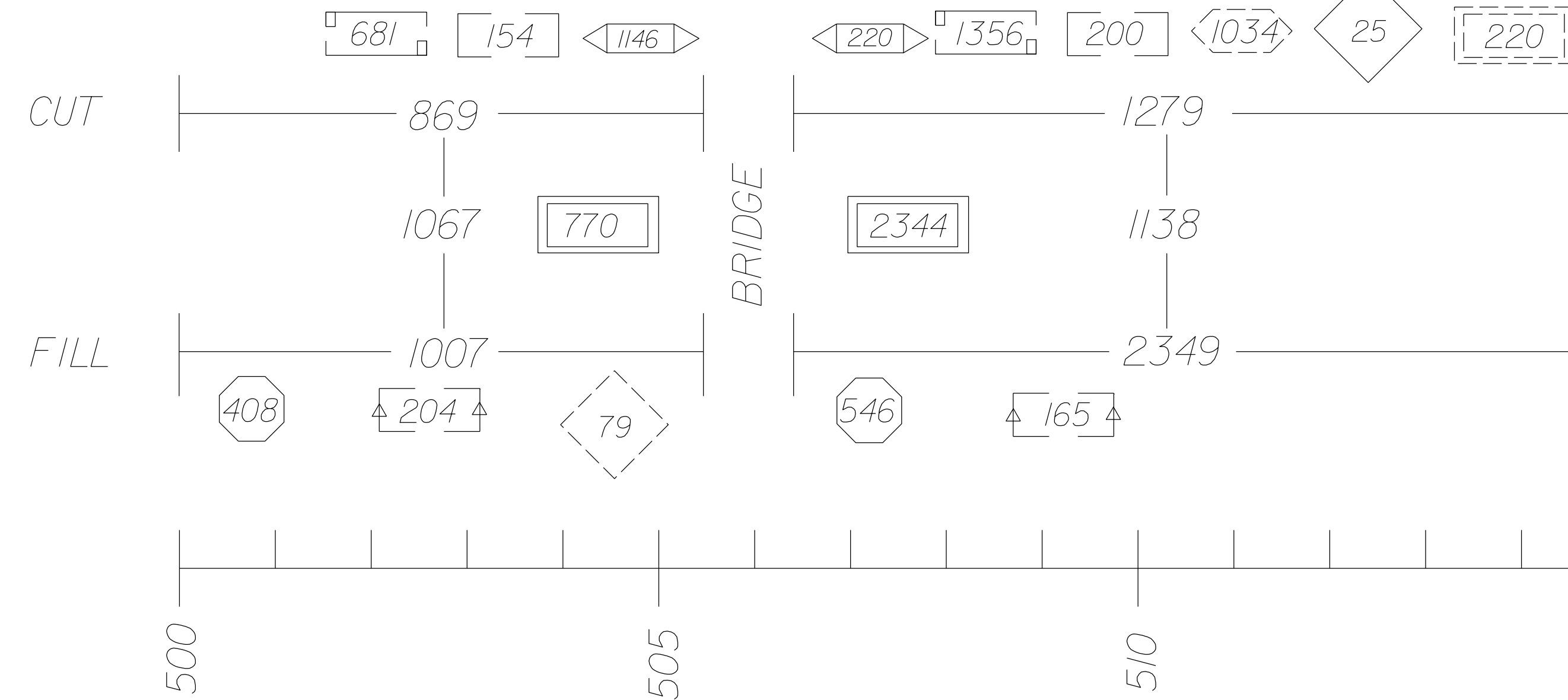

Location	⊗ Roadway Cut		Root Mat In Cut Sections	Root Mat In Fill Sections	⊗ (9) Excavation Under Bridge		⊗ (9) Exc. - Reloc Channel		Unsuitable Material		Roadway Fill	Entrances		Total Regular Excavation	Total Fill	⊗ (2) Demolition of Pavement		⊗ (5) Stormwater Management Basins	⊗ (6) Borrow (Min. CBR-3.6)
	①	②			Below Subgrade	Above Subgrade	Cut	Fill	Cut	Fill		C. Y.	C. Y.			C. Y.	C. Y.		
	C. Y.	C. Y.	C. Y.	C. Y.	C. Y.	C. Y.	C. Y.	C. Y.	C. Y.	C. Y.	C. Y.	C. Y.	C. Y.	C. Y.	C. Y.	C. Y.	C. Y.	C. Y.	C. Y.
BEFORE BRIDGE	869	681	408	1146					1211		79	2423	1698	358				770	
AFTER BRIDGE	1279	1356	546	220	1034				2514	25	2070	3060	365	220				2344	
FORMULAS	C	D	E	F	G	H	I	J	K	L	M	N	O	P	Q	R	S		
TOTALS	③ 2148	④ 2037	③ ⑦ 954	③ ① 1366	③ ① 1034	③ ⑦	④	⑦ 3725	③ 25	⑦ 79	4493	4758	723	220		⑦	3114		

FORMULAS

Roadway Cut (C) = Unadjusted Cut from Computer Listings or Manual Cross-Sections minus (-) Demolition of Pavement.
 Roadway Fill (J) = Fill Required plus (+) Material for Backfill of Demolition of Pavement Areas in Fill (for heights of fill < 3 feet below subgrade)
 Total Reg. Excav. (M) = C + E + F + H + K
 Total Fill (N) = J + E + H + L + R
 Borrow (S) = [N - (C + F + G + K + P + Q - D - I) x Compaction Factor] ÷ Compaction Factor for Borrow Site
 (Embankment) (S) = N - (C + F + K + P + Q - D - I) (Embankment = Total Fill - Usable Cut) Estimated Material to be obtained off-site.

The borrow quantity shown was computed on the basis of the average shrinkage or swell factor for the general vicinity of the project. The contractor will be responsible for determining the actual factor for the site(s) from which he proposes to secure borrow material needed to complete this project.

The embankment quantity shown has not been adjusted for shrinkage or swell factors. The contractor will be responsible for determining the effect of the shrinkage or swell factor of the embankment material, and no adjustment will be made in pay quantities for this factor. The contractor shall determine the actual quantity of embankment material needed to complete this project.

PROJECT	XXXX-XXX-XXX	SHEET NO.	2G
---------	--------------	-----------	----

FIGURE 2H - 25 SAMPLE GRADING DIAGRAM AND SUMMARY SHEET

9/2/2014
9:0:46 AM

Incidental Summary Sheet.dgn
Plotted By: stewartl@lls

SURVEYED BY _____
SUPERVISED BY _____
DESIGNED BY _____

DESIGN FEATURES RELATING TO CONSTRUCTION OR TO REGULATION AND CONTROL OF TRAFFIC MAY BE SUBJECT TO CHANGE AS DEEMED NECESSARY BY THE DEPARTMENT

REVISED	STATE	FEDERAL AID PROJECT	ROUTE	STATE PROJECT	SHEET NO.
	VA.		XXX	XXXX-XXX-XXX, RW-20X C-50X	2H

SHEET NO.	INCIDENTAL SUMMARY																	MAINTENANCE OF TRAFFIC																																						
	MOBILIZATION	CONSTRUCTION SURVEYING	CLEARING & GRUBBING	STD COMBINATION CURB & GUTTER CG-7	RADIAL COMBINATION CURB & GUTTER CG-7	R/W MONUMENT RM-2	STD CURB CG-2	RADIAL CURB CG-2	CG-12 DEFECTABLE WARNING SURFACE	DEMOLITION OF PAVEMENT	STD COMBINED CURB & GUTTER CG-6	RADIAL COMBINED CURB & GUTTER CG-6	ALTERNATE BREAKAWAY CABLE TERM/GR-9	GUARDRAIL TERMINAL GR-7	FIELD OFFICE TYPE I	HYDRAULIC CEMENT CONC. SIDEWALK 4"	NS REMOVE EXISTING GUARDRAIL	FIXED OBJECT ATTACH GR-FOA-2 Type I	FIXED OBJECT ATTACH GR-FOA-1 Type II	FIXED OBJECT ATTACH GR-FOA-1 Type I	GUARDRAIL GR-2	ASPHALT BACKUP MAT'L	ASPHALT CONCRETE CURB MC-3B	TRAFFIC BARRIER CONCRETE MB-7D	RADIAL GUARDRAIL GR-2	HYDRAULIC CEMENT CONC. SIDEWALK 7"	SAW CUT 16'	FLAGGER SERVICE	ELECTRONIC ARROW	WARNING LIGHT (TYPE A)	GROUP 2 CHANNELIZING	TRAFFIC BARRIER CONCRETE MBTD PC	PAVED DITCH PG-2A	IMPACT ATTENUATOR SERV (TYPE TL-3)	IMPACT ATTENUATOR SERV (TYPE I-1-12)	ALLOWING DUST	CONST. PAVE. MARKING TYD WIDTH 4"	CONST. PAVE. MARKING TYD WIDTH 24"	CONST. PAVE. MARKING TYD WIDTH 8"	CONST. PAVE. MESS. MARKING TYPE D AND MESS. ARROW	ERADICATION OF EXISTING PAVEMENT MARKING	TEMPORARY PAVEMENT MARKER, TWO WAY	GEOTEXTILE (EMBANKMENT STABILIZATION)	TYPE III BARRICADE (WIDTH) 4 FT.	CONSTRUCTION SIGNS	TRUCK MOUNTED ATTENUAT	PORTABLE CHANGABLE MESSAGE SIGNS 2 EA.									
	LS.	LS.	LS.	LF.	LF.	EA	LF.	LF.	SQ.YD.	SQ.YD.	LF.	LF.	EA	EA	MO.	SY	LF	EA	EA	EA	LF	TON	LF	LF	LF.	SY	LF.	HR	HR	HR	DAY	DAY	LF	SY	EA	EA	HR.	LF	LF	LF	EA	LF	EA	SY	EA	SF	HR.	HR.								
3									210																																															
4									2704																																															
5									4357																																															
6				74			13		2.0	3249																																														
7				366						1987																																														
8				397	89		49	7	3.2	4820	80																																													
9				439	76		68	13	8	3538	67	105																																												
Sequence of Con.																																																								
TOTAL	LS.	LS.	LS.	1276	165	16	130	20	13.2	20,865	147	105	5	1	MO.	79	1725	3	2	1	1630	68	1488	276	141	67	557	500	500	4,500	51,200	10,028	155	16	12	800	31,800	500	1,600	10	15,000	200	450	6	350	100	1,000									

⊗ Denotes : Items to be paid for on basis of Plan Quantities in accordance with Current Road and Bridge Specifications

PARCEL NO.	DEMO. NO.	STATION	PARCEL OWNER	DESCRIPTION	PAY ITEM
008	D-701	526+60 LT	BOARD OF COUNTY SUPERVISORS OF PRINCE WILLIAM CO., VIRGINIA	RELOCATE - SIGN ON WOOD POSTS	LS.
010	D-702	527+30 RT	HUGILL, THOMAS B. & PAMELA S.	DEMO. - METAL SIGN ON METAL POSTS	LS.
011	D-703	528+20 RT	L. & J. KLINE'S, L.L.C.	DEMO. - METAL SIGN ON METAL POSTS	LS.
008	D-704	526+15 LT	BOARD OF COUNTY SUPERVISORS OF PRINCE WILLIAM CO., VIRGINIA	RELOCATE - SIGN ON WOOD POSTS	LS.

PLAN NO.	PROJECT	FILE NO.	SHEET NO.
	XXXX-XXX-XXX		2H

FIGURE 2H - 26 SAMPLE INCIDENTAL SUMMARY SHEET

9/2/2014
9:50:07 AM

Radial Offset Sheet.dgn
Plotted By: stewart1.wills

PROJECT MANAGER: <Project_Mgr_Name (000) 000-0000 (District)> -----
SURVEYED BY, DATE: <Surveyor_Name (000) 000-0000 (District)> -----
DESIGN BY: <Designer_Name (000) 000-0000 (District)> -----
SUBSURFACE UTILITY BY, DATE: <Surveyor_Name (000) 000-0000 (District)> -----

REVISED	STATE		PROJECT	SHEET NO.
	STATE	ROUTE		
	VA.	XXX	XXXX-XXX-XXX, C-50X	2J

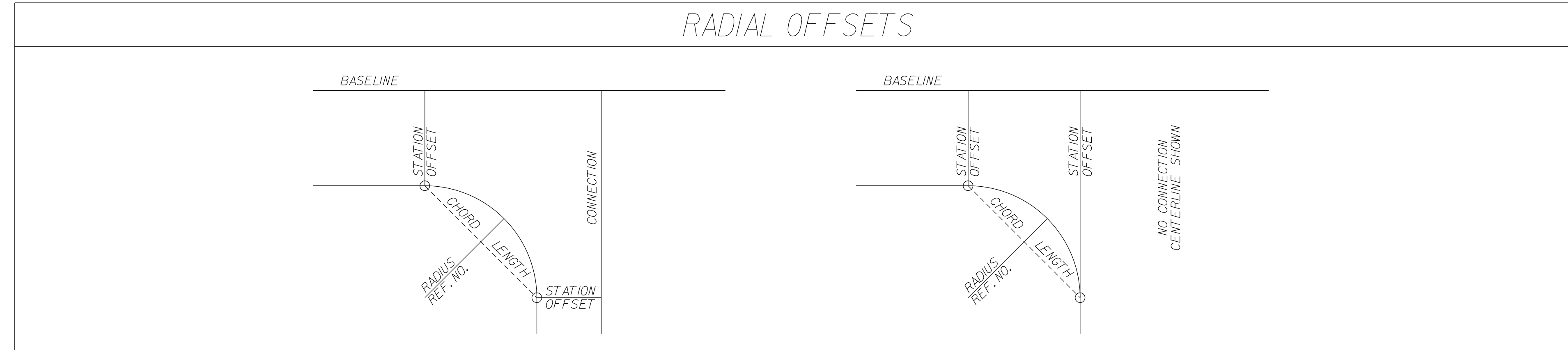

LOCATION (REF. NO.)	BASELINE		CONNECTION		RADIUS LENGTH	CHORD LENGTH	CURVE LENGTH	LOCATION (REF. NO.)	BASELINE		CONNECTION		RADIUS LENGTH	CHORD LENGTH	CURVE LENGTH
	SHEET - ITEM	STATION	OFFSET	STATION					OFFSET	FEET	FEET	FEET			
9-1	148+92.33	19.00' Lt	50+57.52	14.00' Lt	50.00	64.00	69.45	12-1	171+28.94	19.00' Lt	90+58.69	12.00' Lt	40.00	56.35	62.59
9-2	150+33.21	19.00' Lt	50+58.77	31.03' Rt	50.00	58.02	61.90	12-2	172+32.94	19.00' Lt	90+59.00	12.00' Rt	40.00	56.57	62.83
9-3	152+18.91	19.00' Rt			30.00	42.46	47.12	13-1	178+32.53	19.00' Rt	10+69.03	18.50' Rt	50.00	70.62	78.41
	152+48.95	60.25' Rt						13-2	179+69.24	19.00' Rt	10+68.97	18.50' Lt	50.00	70.59	78.37
9-4	152+86.36	54.00' Rt			35.00	49.50	54.98								
	153+21.36	19.00' Rt													
10-1	155+99.92	19.00' Lt	60+75.18	18.50' Lt	50.00	71.79	80.07	14-2	192+17.00	16.30' Lt			943.05	159.63	159.82
10-2	157+23.69	19.00' Lt	60+57.83	18.50' Rt	50.00	61.26	65.93		193+80.00	18.70' Lt					
10-3	157+60.26	26.37' Rt			35.00	69.87	105.64								
	157+63.17	96.18' Rt													
10-4	157+63.17	96.18' Rt			35.00	43.13	44.79								
	157+98.90	121.62' Rt													
10-5	157+88.45	143.10' Rt			34.88	49.19	54.77								
	157+36.27	119.69' Rt													
10-6	157+36.27	119.69' Rt			34.88	49.38	54.77								
	157+05.36	162.09' Rt													
10-7	156+62.06	50.91' Rt			35.00	47.96	52.84								
	156+24.73	19.00' Rt													
10-8	158+17.78	19.40' Rt			35.00	5.33	5.34								
	158+23.14	19.00' Rt													
10-9	159+74.44	19.00' Lt	70+69.00	18.50' Lt	50.00	70.71	78.54								
10-10	161+11.44	19.00' Lt	70+69.00	18.50' Rt	50.00	70.71	78.54								
11-1	162+85.14	19.00' Rt			35.00	48.44	53.50								
	163+18.31	53.08' Rt													
11-1	163+56.03	51.83' Rt			35.00	47.16	51.75								
	163+88.08	19.00' Rt													
11-3	165+29.17	19.00' Rt	80+56.36	18.50' Rt	50.00	61.38	66.08								
11-4	166+49.52	19.00' Rt	80+79.51	18.50' Lt	50.00	72.82	81.57								

DESIGN FEATURES RELATING TO CONSTRUCTION OR TO REGULATION AND CONTROL OF TRAFFIC MAY BE SUBJECT TO CHANGE AS DEEMED NECESSARY BY THE DEPARTMENT

PROJECT	XXXX-XXX-XXX	SHEET NO.	2J
---------	--------------	-----------	----

Cell Revised 12/11/12

FIGURE 2H - 28 SAMPLE RADIAL OFFSET SHEET

9/2/2014
9:46:07 AM

Metes and Bound Data
Plotted By: Stewart Willis

PROJECT MANAGER M. Tolson, P.E. (804) 524-6407 (Richmond District)
SURVEYED BY Steve Bergeron, (804) 524-6157 (Richmond District)
DESIGN SUPERVISED BY A. Wilkinson, P.E. (804) 524-6150 (Richmond District)
DESIGNED BY Graeme A. Cleveland (804) 524-6504 (Richmond District)

METES AND BOUNDS DATA

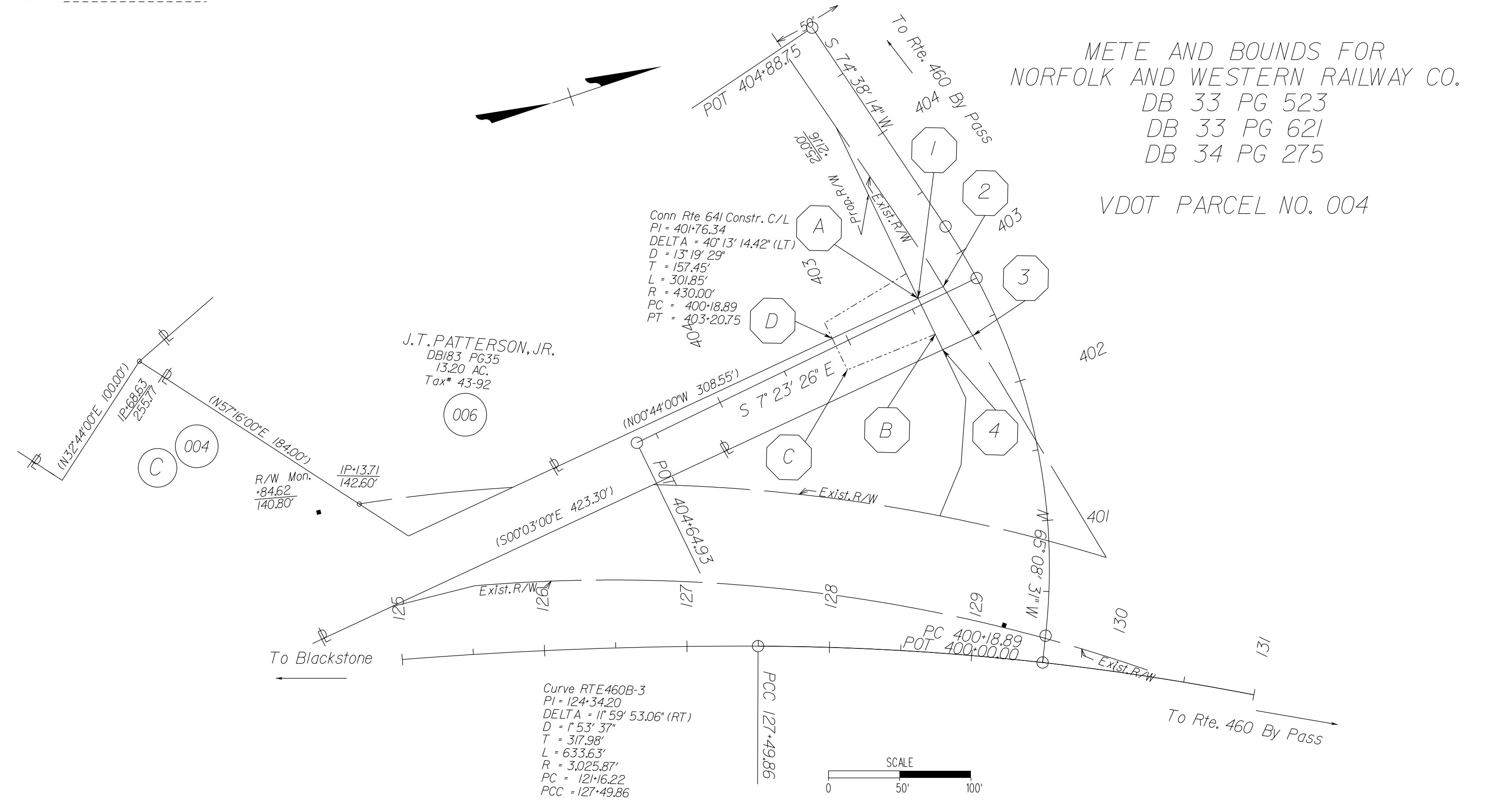

METE AND BOUNDS FOR
NORFOLK AND WESTERN RAILWAY CO.
DB 33 PG 523
DB 33 PG 621
DB 34 PG 275

VDOT PARCEL NO. 004

REVISED	STATE	ROUTE	STATE PROJECT	SHEET NO.
	VA.	XXX	XXXX-XXX-XXX, C50X R20X	2K

DESIGN FEATURES RELATING TO CONSTRUCTION OR TO REGULATION AND CONTROL OF TRAFFIC MAY BE SUBJECT TO CHANGE AS DEEMED NECESSARY BY THE DEPARTMENT

VDOT (Division) or Co. Name (Location), Virginia (TECHNICAL DISCIPLINE)	VDOT (Division) or Co. Name (Location), Virginia (TECHNICAL DISCIPLINE)
---	---

PARCEL 004

PROJECT COORDINATES PROP. RIGHT OF WAY	
POINT 1	POINT 3
N 281.457.1270	N 281.437.7459
E 3,437,845.7156	E 3,437,847.9292
POINT 1 TO POINT 3 S63°05'W 19.507'	

PARCEL 004

PROJECT COORDINATES TEMPORARY CONSTR. EASEMENT	
POINT A	POINT C
N 281.457.1270	N 281.394.2016
E 3,437,845.7156	E 3,437,877.5987
POINT A TO POINT C S26°52'4"E 70.542'	

SECTION	LINE	BEARING	LENGTH	CORD LENGTH	DELTA	RADIUS	ARC LENGTH	SQ. FT.	ACRES
1-2	1-2	N77°26'58"E	40.223'						
2-3	2-3	S6°30'57"E	23.33'						
3-4	3-4	S82°54'15"W	40.002'						
4-1	4-1	N6°30'57"W	19.507'						
TOTAL ACRES OF PROPOSED RIGHT OF WAY								856.7600	0.0197
A-B	A-B	N82°54'15"E	27.932'						
B-C	B-C	S3°35'27"E	66.506'						
C-D	C-D	S82°36'34"W	24.539'						
D-A	D-A	N6°30'57"W	66.512'						
TOTAL ACRES OF TEMPORARY CONSTRUCTION EASEMENT								1743.0600	0.0400

POINT	PLUS	OFFSET
1	402-8871 CONN RTE 641	42.86' LT.
2	402-8459 CONN RTE 641	23.40' LT.
3	402-4236 CONN RTE 641	20.02' LT.
4	402-4164 CONN RTE 641	43.34' RT.
A	402-8611 CONN RTE 641	42.86' RT.
B	402-5507 CONN RTE 641	43.63' RT.
C	402-5977 CONN RTE 641	110.03' RT.
D	402-9269 CONN RTE 641	109.15' RT.

METE AND BOUNDS FOR VIRGINIA POLYTECHNIC INSTITUTE AND STATE UNIVERSITY DB 352 PG 383 PB 6 PG 85 - 92 1,186.060 ACRES TAX MAP 43 - 132

VDOT PARCEL NO. 012

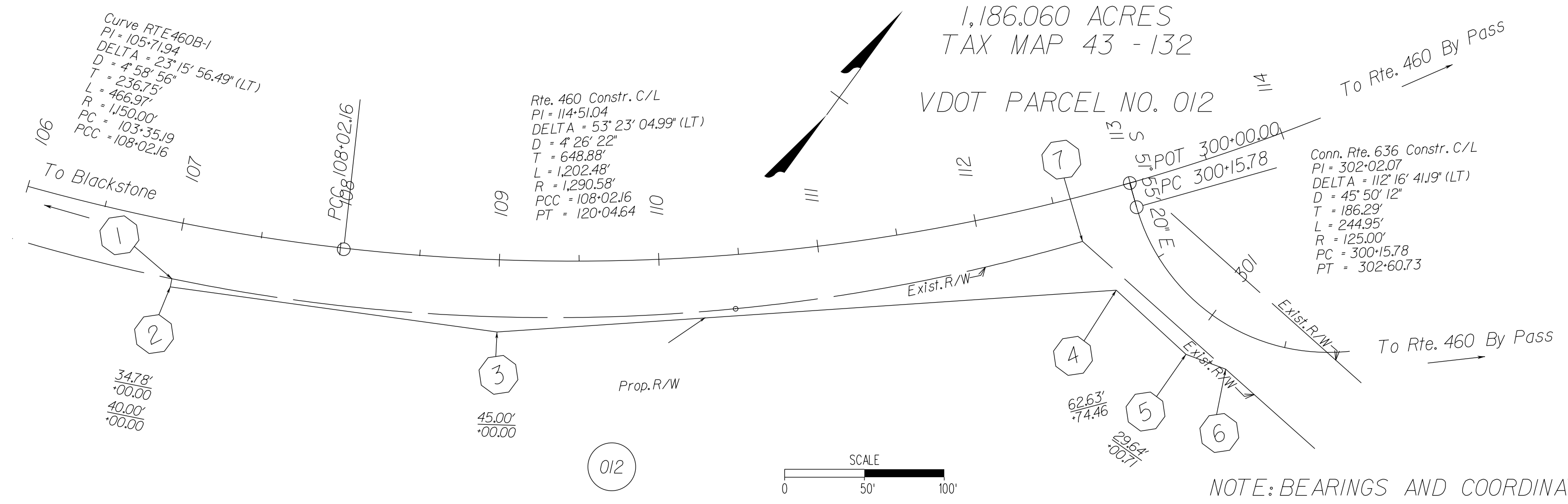

PARCEL 012

PROJECT COORDINATES PROP. RIGHT OF WAY	
POINT 1	POINT 6
N 279,885.3556	N 279,842.7511
E 3,437,821.8628	E 3,437,742.3568
POINT 1 TO POINT 6 N58°45'12"W 663.098'	

SECTION	LINE	BEARING	LENGTH	CORD LENGTH	DELTA	RADIUS	ARC LENGTH	SQ. FT.	ACRES
1-2	1-2	S24°49'46"E	5.216'						
2-3	2-3	N67°42'12"E	206.812'						
3-4	3-4	N47°59'4"E	389.098'						
4-5	4-5	S83°33'37"E	59.360'						
5-6	5-6	N71°19'1"E	26.582'						
6-7	6-7	N84°24'00"W	120.296'						
7-1	7-1	S57°30'02"W	571.404'		28702°52'	1179,000'	577.149'		
TOTAL ACRES PROPOSED RIGHT OF WAY								6,074.1230	0.1394

POINT	PLUS	OFFSET
1	309-1709 CONN RTE 636	25.00' RT.
2	307-1394 CONN RTE 636	25.00' RT.
3	309-3966 CONN RTE 636	25.00' RT.
4	309-7609 CONN RTE 636	25.00' RT.
5	313-6056 CONN RTE 636	25.00' RT.
6	314-6641 CONN RTE 636	35.42' LT.
7	310-0762 CONN RTE 636	70.82' LT.

NOTE: BEARINGS AND COORDINATES BASED ON PROJECT COORDINATES

PROJECT	XXXX-XXX-XXX	SHEET NO.	2K
---------	--------------	-----------	----

FIGURE 2H - 29 SAMPLE METES AND BOUNDS DATA SHEET

9/5/2014
8:26:2 AM

LIMITED ACCESS HIGHWAY By Resolution of Highway Commission dated Oct, 04 1956

PROJECT MANAGER LAURENCE, FARRELL, P.E. (540) 829-7627
SURVEYED BY PRECISION MEASUREMENTS, INC. (804) 340-5229
DESIGN SUPERVISED BY JOSHUA S. WADE, P.E. (703) 352-7188
DESIGNED BY PARSONS TRANSPORTATION GROUP, INC. (703) 934-2300

CROSSOVER-1 DETAIL

REVISED	STATE	ROUTE	STATE PROJECT	SHEET NO.
No. Description Date	VA.	64	0064-054-703, RW-201 C-501	2L

DESIGN FEATURES RELATING TO CONSTRUCTION OR TO REGULATION AND CONTROL OF TRAFFIC MAY BE SUBJECT TO CHANGE AS DEEMED NECESSARY BY THE DEPARTMENT

Parsons Transportation Group Inc. of Virginia Fairfax, Virginia ROADWAY ENGINEER

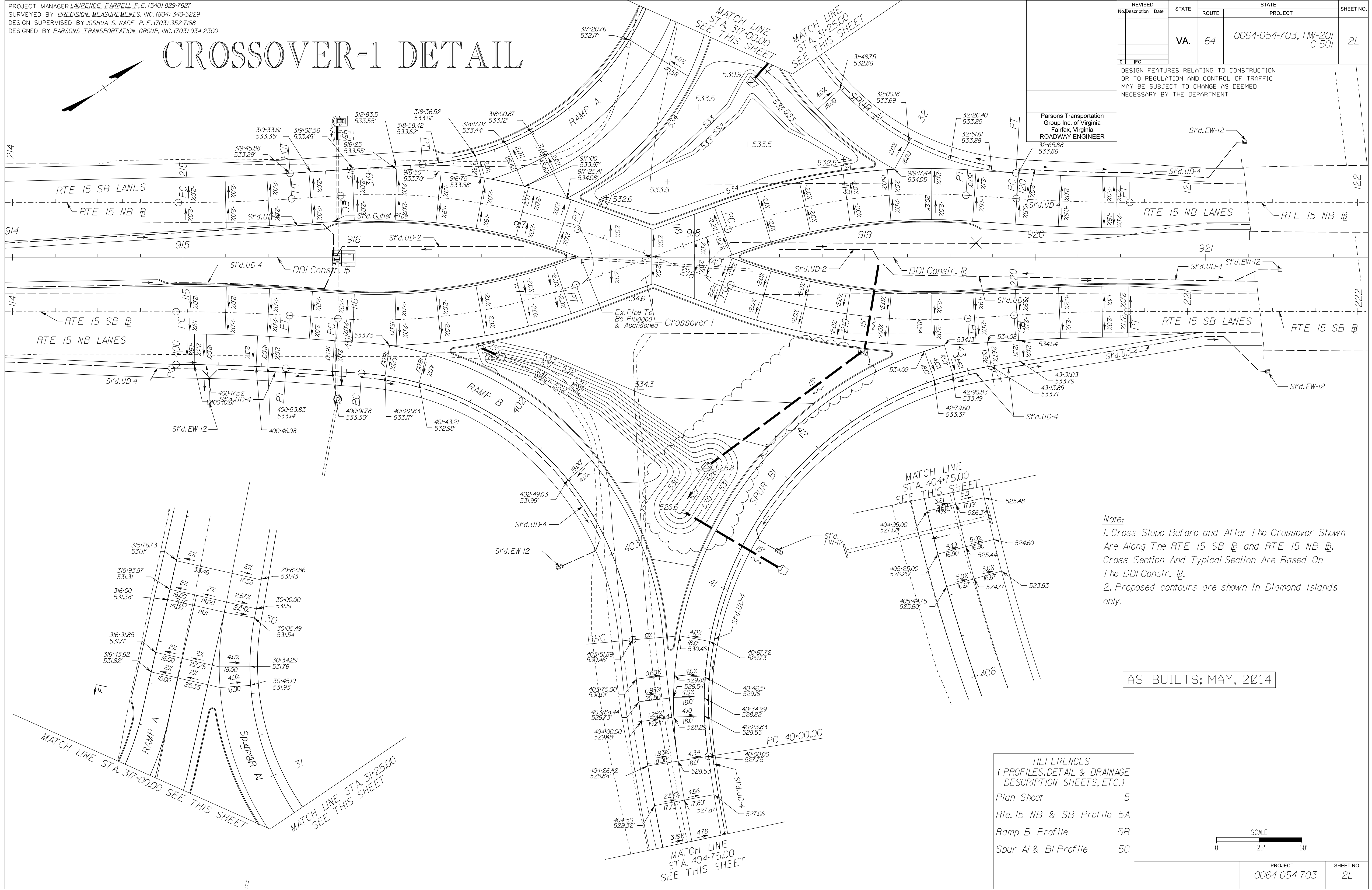

Note:
 1. Cross Slope Before and After The Crossover Shown Are Along The RTE 15 SB & RTE 15 NB. Cross Section And Typical Section Are Based On The DDI Constr. B.
 2. Proposed contours are shown in Diamond Islands only.

AS BUILTS; MAY, 2014

REFERENCES (PROFILES, DETAIL & DRAINAGE DESCRIPTION SHEETS, ETC.)

Plan Sheet	5
Rte. 15 NB & SB Profile	5A
Ramp B Profile	5B
Spur AI & BI Profile	5C

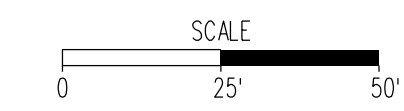

PROJECT	0064-054-703	SHEET NO.	2L
---------	--------------	-----------	----

FIGURE 2H - 30 SAMPLE DIVERSION DIAMOND INTERCHANGE DETAIL SHEET

9/5/2014
8:28:34 AM

Plan Sheet (1/14/14)
Plotted By: stewartjwills

PROJECT MANAGER _____
SURVEYED BY, DATE _____
DESIGN BY _____
SUBSURFACE UTILITY BY, DATE _____

REVISED	STATE	ROUTE	STATE PROJECT	SHEET NO.
1/14/14	VA	XXX	XXXX-XXX-XXX, RW-20X, C-50X	3

DESIGN FEATURES RELATING TO CONSTRUCTION OR TO REGULATION AND CONTROL OF TRAFFIC MAY BE SUBJECT TO CHANGE AS DEEMED NECESSARY BY THE DEPARTMENT

VDOT Location and Design
Richmond, Virginia
ROADWAY ENGINEER

VDOT Location and Design
Richmond, Virginia
HYDRAULIC ENGINEER

THESE PLANS ARE UNFINISHED AND ARE NOT TO BE USED FOR ANY TYPE OF CONSTRUCTION.

UTILITY OWNERS

Water & Sanitary :
Town of Culpeper
15048 Service Lane
Culpeper, Virginia 22701
(540) 825-0285

Cable Television :
Comcast Communications Corporation
400 Westfield Road
Charlottesville, VA 22901
(434) 951-3700

Gas :
Columbia Gas
4176 Blue Dau Drive
Warrenton, Virginia 20187
(540) 349-2773

Telephone :
Verizon
502 E. Piedmont Street
Culpeper, Virginia 22701
(540) 829-2709

Electric :
Dominion Virginia Power
1719 Hydraulic Road
Charlottesville, VA 22901
(434) 972-6727

Rappahannock Electric Cooperative
601 Madison Road
Culpeper, VA 22701
(540) 825-8373

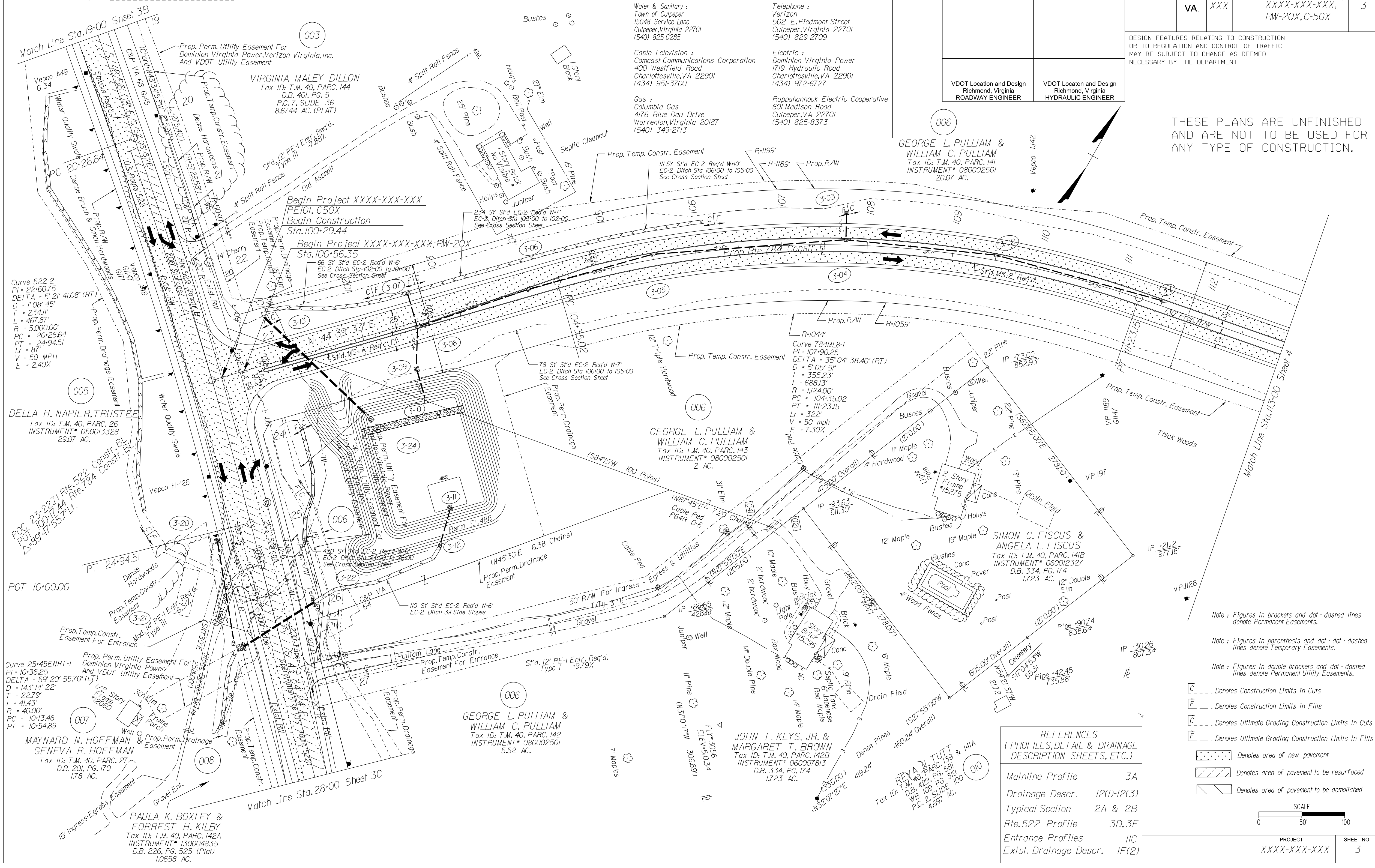

Note: Figures in brackets and dot-dashed lines denote Permanent Easements.
Note: Figures in parenthesis and dot-dashed lines denote Temporary Easements.
Note: Figures in double brackets and dot-dashed lines denote Permanent Utility Easements.

--- Denotes Construction Limits in Cuts
--- Denotes Construction Limits in Fills
--- Denotes Ultimate Grading Construction Limits in Cuts
--- Denotes Ultimate Grading Construction Limits in Fills
--- Denotes area of new pavement
--- Denotes area of pavement to be resurfaced
--- Denotes area of pavement to be demolished

REFERENCES
(PROFILES, DETAIL & DRAINAGE DESCRIPTION SHEETS, ETC.)

Mainline Profile	3A
Drainage Descr.	12(1)-12(3)
Typical Section	2A & 2B
Rte. 522 Profile	3D, 3E
Entrance Profiles	11C
Exist. Drainage Descr.	1F(2)

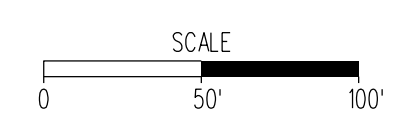

PROJECT	SHEET NO.
XXXX-XXX-XXX	3

FIGURE 2H - 31 SAMPLE 1 PLAN SHEET

9/5/2014
8:30:28 AM

Plan Sheet (2).dgn
Plotted: Bystewart\jwillis

LIMITED ACCESS HIGHWAY
By Resolution of Commonwealth Transportation Board dated January 17, 1991

PROJECT MANAGER BY _____ Gas Property Of: American Electric Power
SURVEYED BY _____ Columbia Gas of Virginia, Inc. (Transmission)
DESIGNED SUPERVISED BY _____ P.O. Box 6160 Lynchburg, VA, 23405-6160
DESIGNED BY _____ Electric Lines Property Of: American Electric Power Co. P.O. Box 1000 Lynchburg, VA, 24505-1000

UTILITY OWNERS:
Water & Sewer Lines Property Of: City Of Lynchburg
Dept Of Public Works
P.O. Box 60
Lynchburg, VA, 24505
Amherst County Service Authority
P.O. Box 100
Madison Heights, VA, 24572-0100

SWM Entrance Constr. B.L.
DELTA = 91°37'56.40" RT
D = 229'10'59.22"
T = 25.72'
L = 39.98'
R = 25.00'
PC = 11+88.07 (B)
PI = 11+88.07 (B)
PT = 12+28.05 (B)

053
WILLIAM HENRY CHRISTIAN, ESTATE
LUCILLE MCCOY CHRISTIAN, ESTATE
JAMES EDWARD CHRISTIAN
ANNE JACKSON CHRISTIAN
HARRY B. CHRISTIAN
DB231 PG351 & WB135 PG132
PB'C PG27
431.26 AC.

SWM Entrance Constr. B.L.
DELTA = 45°22'11.46" LT
D = 229'10'59.22"
T = 10.45'
L = 19.80'
R = 25.00'
PC = 11+24.72 (B)
PI = 11+35.77 (B)
PT = 11+44.51 (B)

DESIGN FEATURES RELATING TO CONSTRUCTION OR TO REGULATION AND CONTROL OF TRAFFIC MAY BE SUBJECT TO CHANGE AS DEEMED NECESSARY BY THE DEPARTMENT

REVISION	FHWA REGION	STATE	FEDERAL AID PROJECT	ROUTE	STATE PROJECT	SHEET NO.
7/31/98						
2/24/98						
5/5/98						
11/4/98						
6/04/01	3	VA		XXX	XXXX-XXX-XXX, RW-20X C-50X	5
12/07/01						

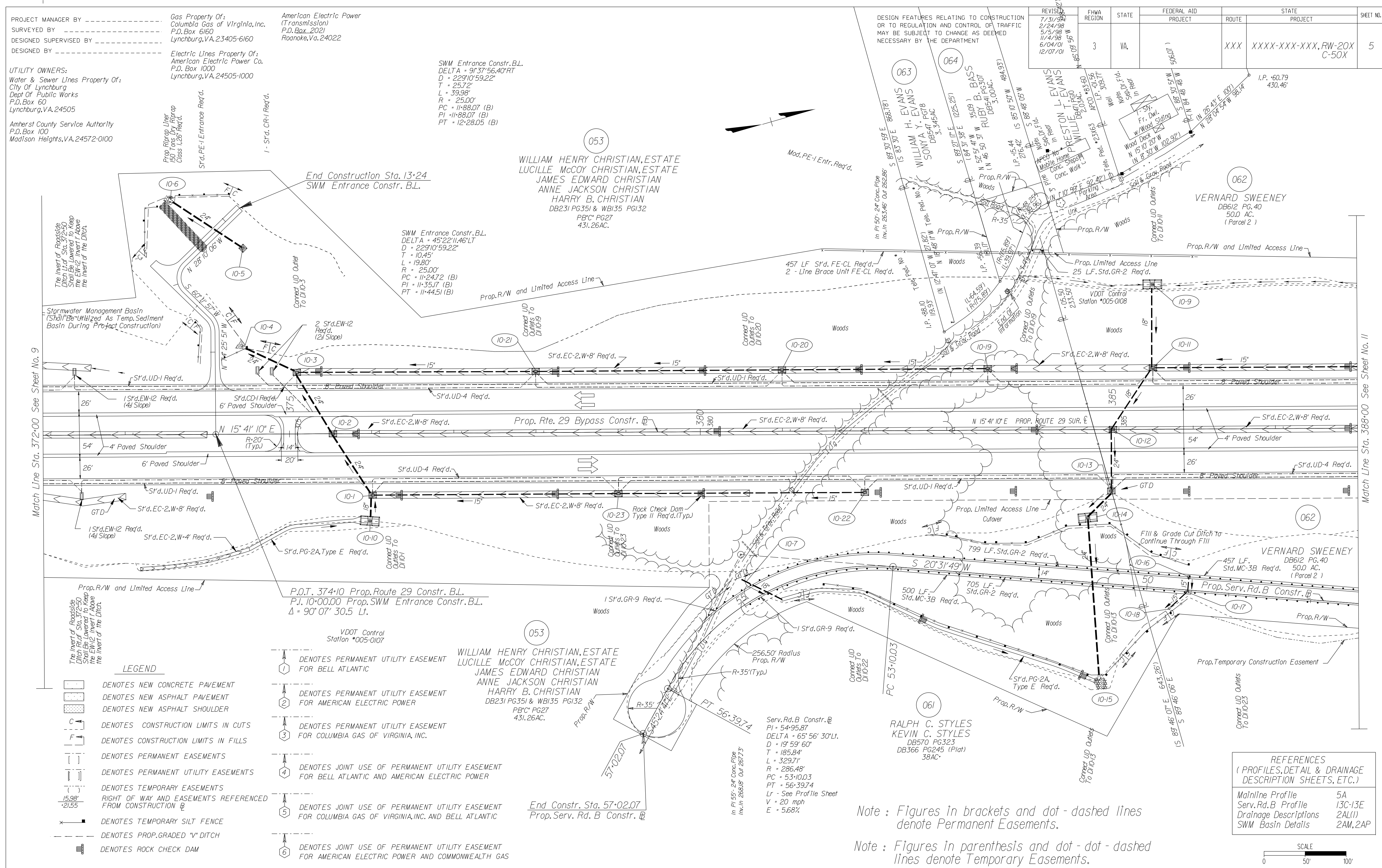

- LEGEND**
- DENOTES NEW CONCRETE PAVEMENT
 - DENOTES NEW ASPHALT PAVEMENT
 - DENOTES NEW ASPHALT SHOULDER
 - DENOTES CONSTRUCTION LIMITS IN CUTS
 - DENOTES CONSTRUCTION LIMITS IN FILLS
 - DENOTES PERMANENT EASEMENTS
 - DENOTES PERMANENT UTILITY EASEMENTS
 - DENOTES TEMPORARY EASEMENTS
 - DENOTES TEMPORARY SILT FENCE
 - DENOTES TEMPORARY SILT FENCE
 - DENOTES PROP. GRADED "V" DITCH
 - DENOTES ROCK CHECK DAM
 - DENOTES PERMANENT UTILITY EASEMENT FOR BELL ATLANTIC
 - DENOTES PERMANENT UTILITY EASEMENT FOR AMERICAN ELECTRIC POWER
 - DENOTES PERMANENT UTILITY EASEMENT FOR COLUMBIA GAS OF VIRGINIA, INC.
 - DENOTES JOINT USE OF PERMANENT UTILITY EASEMENT FOR BELL ATLANTIC AND AMERICAN ELECTRIC POWER
 - DENOTES JOINT USE OF PERMANENT UTILITY EASEMENT FOR COLUMBIA GAS OF VIRGINIA, INC. AND BELL ATLANTIC
 - DENOTES JOINT USE OF PERMANENT UTILITY EASEMENT FOR AMERICAN ELECTRIC POWER AND COMMONWEALTH GAS

REFERENCES
(PROFILES, DETAIL & DRAINAGE DESCRIPTION SHEETS, ETC.)

Mainline Profile	5A
Serv. Rd. B Profile	13C-13E
Drainage Descriptions	2A(1)
SWM Basin Details	2AM, 2AP

Note: Figures in brackets and dot-dashed lines denote Permanent Easements.

Note: Figures in parenthesis and dot-dot-dashed lines denote Temporary Easements.

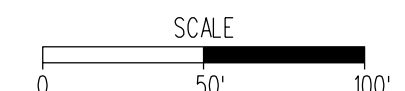

PLAN NO.	PROJECT	FILE NO.	SHEET NO.
A	XXXX-XXX-XXX		5

FIGURE 2H - 32 SAMPLE 2 PLAN SHEET

9/5/2014
8:32:05 AM

Plan Sheet (3/1dgn)
Plotted By: stewartwillis

PROJECT MANAGER _____
SURVEYED BY, DATE _____
DESIGN BY _____
SUBSURFACE UTILITY BY, DATE _____

REVISED	STATE		PROJECT	SHEET NO.
	ROUTE			
12-9-13 2-19-14	VA.	XXX	XXXX-XXX-XXX, RW-20X,C-50X	7
DESIGN FEATURES RELATING TO CONSTRUCTION OR TO REGULATION AND CONTROL OF TRAFFIC MAY BE SUBJECT TO CHANGE AS DEEMED NECESSARY BY THE DEPARTMENT				
VDOT Location and Design Richmond, Virginia ROADWAY ENGINEER		VDOT Location and Design Richmond, Virginia HYDRAULIC ENGINEER		

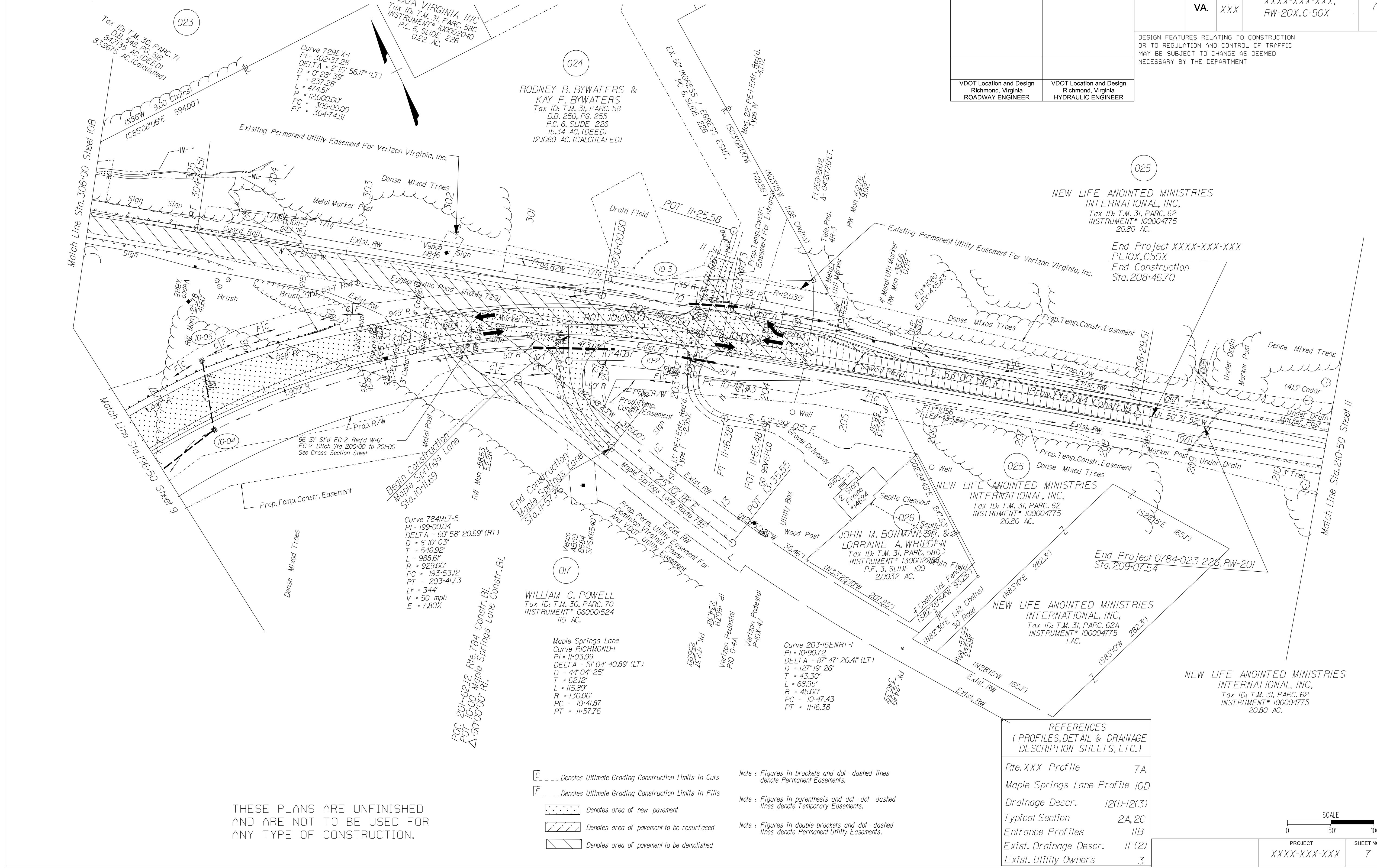

Cell Revised 12/11/12

9/8/2014
8:28:12 AM

Plan Sheet Roundabout (4) Adj
Plotted By: stewartwillis

PROJECT MANAGER _____
SURVEYED BY _____
DESIGN SUPERVISED BY _____
DESIGNED BY _____

Utility Owners :

Mr. Art Coleman
Comcast Cable Communications
195 Ralville Road
Winchester, VA 22602
(540) 504-0942

Mr. John Dalley
Rappahannock Electric Cooperative
137 Kelley Court
Front Royal, VA 22630
(540) 622-5162

Mr. Steve Heltzel
Shenandoah Telephone Company
P.O. Box 459
Edinburg, VA 22824
(540) 984-5363

Mr. Rick Boor
Town Of Berryville
23 East Main St.
Berryville, VA 22611
(540) 955-4843

Mr. Mike Wallace
Verizon Virginia, Inc.
404 Hillandale Lane
Winchester, VA 22602
(540) 665-3153

Mr. Wayne France
Washington Gas and Light Company
350 Hillandale Lane
P.O. Box 2400
Winchester, VA 22604
(540) 868-1923

Mr. Bob Levi
Clarke County
County Maintenance Director
129 Ransburg Lane
Berryville, VA 22611
(540) 955-5123

COUNTY SCHOOL BOARD
OF CLARKE COUNTY, VIRGINIA
DB 74 PG 218
46.79 AC.
Tax* 13-A-61

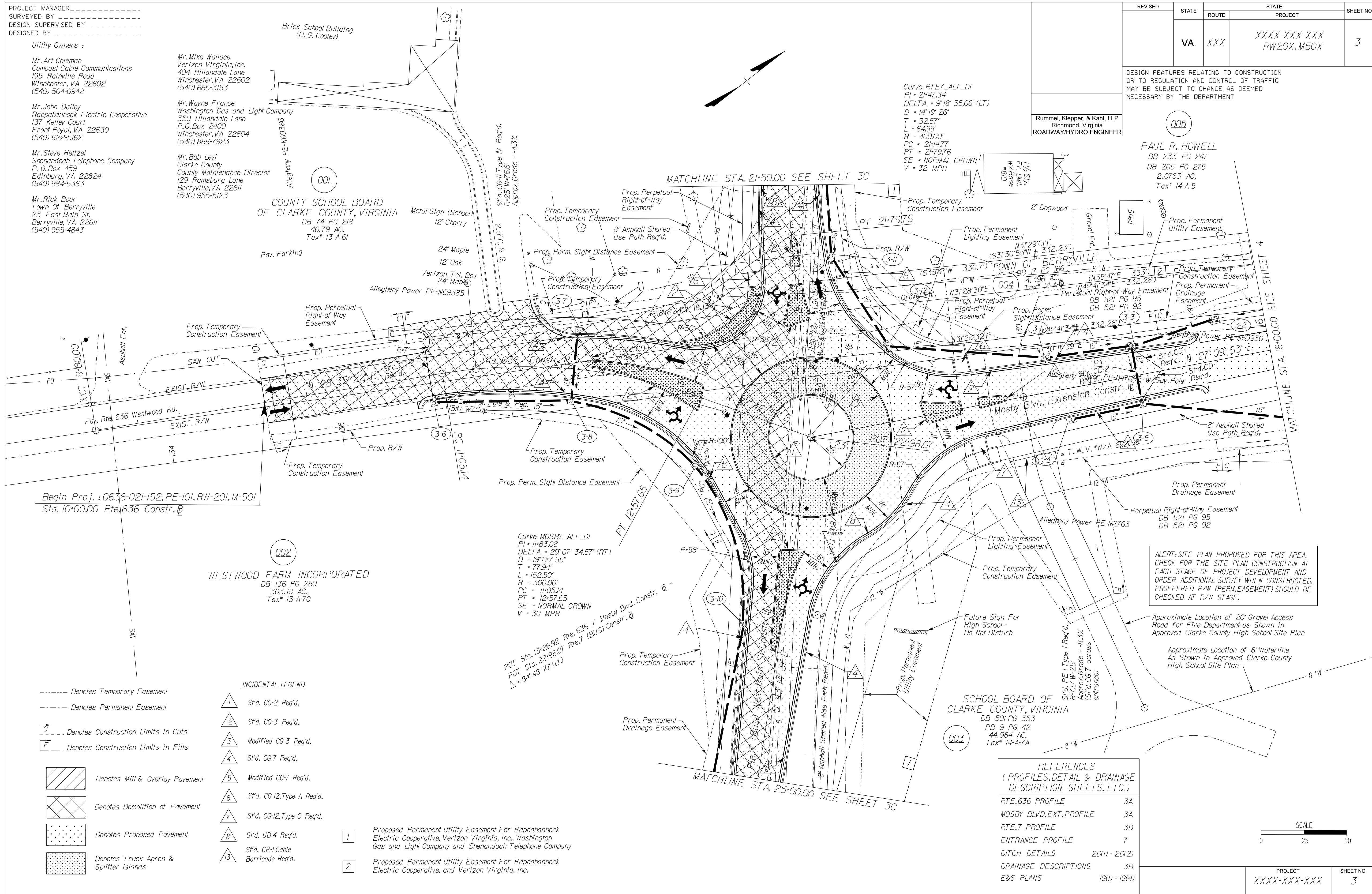

REVISED	STATE		PROJECT	SHEET NO.
	VA.	XXX		
			XXXX-XXX-XXX RW20X, M50X	3

DESIGN FEATURES RELATING TO CONSTRUCTION OR TO REGULATION AND CONTROL OF TRAFFIC MAY BE SUBJECT TO CHANGE AS DEEMED NECESSARY BY THE DEPARTMENT

Rummel, Klepper, & Kahl, LLP
Richmond, Virginia
ROADWAY/HYDRO ENGINEER

PAUL R. HOWELL
DB 233 PG 247
DB 205 PG 275
2.0763 AC.
Tax* 14-A-5

Begin Proj.: 0636-021-152, PE-101, RW-201, M-501
Sta. 10+00.00 Rte. 636 Constr. E

WESTWOOD FARM INCORPORATED
DB 136 PG 260
303.18 AC.
Tax* 13-A-70

Curve MOSBY_ALT_DI
PI = 1183.08
DELTA = 23° 07' 34.57" (RT)
D = 19' 05' 55"
T = 77.94'
L = 152.50'
R = 300.00'
PC = 1105.14
PT = 1257.65
SE = NORMAL CROWN
V = 30 MPH

Curve RTE7_ALT_DI
PI = 2147.34
DELTA = 9° 18' 35.06" (LT)
D = 14' 19' 28"
T = 32.57'
L = 64.99'
R = 400.00'
PC = 2114.77
PT = 2179.76
SE = NORMAL CROWN
V = 32 MPH

- INCIDENTAL LEGEND
- Denotes Temporary Easement
 - Denotes Permanent Easement
 - C Denotes Construction Limits in Cuts
 - F Denotes Construction Limits in Fills
 - [Hatched] Denotes Mill & Overlay Pavement
 - [Cross-hatched] Denotes Demolition of Pavement
 - [Dotted] Denotes Proposed Pavement
 - [Stippled] Denotes Truck Apron & Splitter Islands
 - △1 S'd. CG-2 Req'd.
 - △2 S'd. CG-3 Req'd.
 - △3 Modified CG-3 Req'd.
 - △4 S'd. CG-7 Req'd.
 - △5 Modified CG-7 Req'd.
 - △6 S'd. CG-12, Type A Req'd.
 - △7 S'd. CG-12, Type C Req'd.
 - △8 S'd. UD-4 Req'd.
 - △9 S'd. CR-1 Cable Barricade Req'd.

- 1 Proposed Permanent Utility Easement For Rappahannock Electric Cooperative, Verizon Virginia, Inc., Washington Gas and Light Company and Shenandoah Telephone Company
- 2 Proposed Permanent Utility Easement For Rappahannock Electric Cooperative, and Verizon Virginia, Inc.

REFERENCES
(PROFILES, DETAIL & DRAINAGE DESCRIPTION SHEETS, ETC.)

RTE. 636 PROFILE	3A
MOSBY BLVD. EXT. PROFILE	3A
RTE. 7 PROFILE	3D
ENTRANCE PROFILE	7
DITCH DETAILS	2D(1) - 2D(2)
DRAINAGE DESCRIPTIONS	3B
E&S PLANS	1G(1) - 1G(4)

ALERT: SITE PLAN PROPOSED FOR THIS AREA. CHECK FOR THE SITE PLAN CONSTRUCTION AT EACH STAGE OF PROJECT DEVELOPMENT AND ORDER ADDITIONAL SURVEY WHEN CONSTRUCTED. PROFFERED R/W (PERM. EASEMENT) SHOULD BE CHECKED AT R/W STAGE.

Approximate Location of 20' Gravel Access Road for Fire Department as Shown in Approved Clarke County High School Site Plan

Approximate Location of 8' Waterline As Shown in Approved Clarke County High School Site Plan

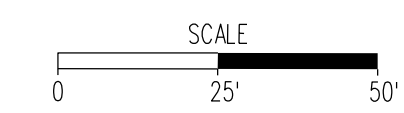

PROJECT	SHEET NO.
XXXX-XXX-XXX	3

FIGURE 2H - 34 SAMPLE 4 PLAN SHEET

9/5/2014
9:03:48 AM

Profile Sheet (11)gjn
Plotted By: stewart.williams

PROJECT MANAGER _____
SURVEYED BY, DATE _____
DESIGN BY _____
SUBSURFACE UTILITY BY, DATE _____

REVISED	STATE	ROUTE	PROJECT	SHEET NO.
	VA.	XXX	XXXX-XXX-XXX, RW-20X,C-50X	3A

THESE PLANS ARE UNFINISHED
AND ARE NOT TO BE USED FOR
ANY TYPE OF CONSTRUCTION.

DESIGN FEATURES RELATING TO CONSTRUCTION
OR TO REGULATION AND CONTROL OF TRAFFIC
MAY BE SUBJECT TO CHANGE AS DEEMED
NECESSARY BY THE DEPARTMENT

VDOT Location and Design
Richmond, Virginia
ROADWAY ENGINEER

SCALE:	1" = 50' HORZ.	1" = 10' VERT.
Rte. 184 Proposed Grade		595
STA = 120+00.00		
FI = 551.91		585
SSD = 727'		580
ex = -16.52'		575
K = 245		570
L = 1,800.00		565
V = 65MPH		560

ROUTE XXX PROFILE

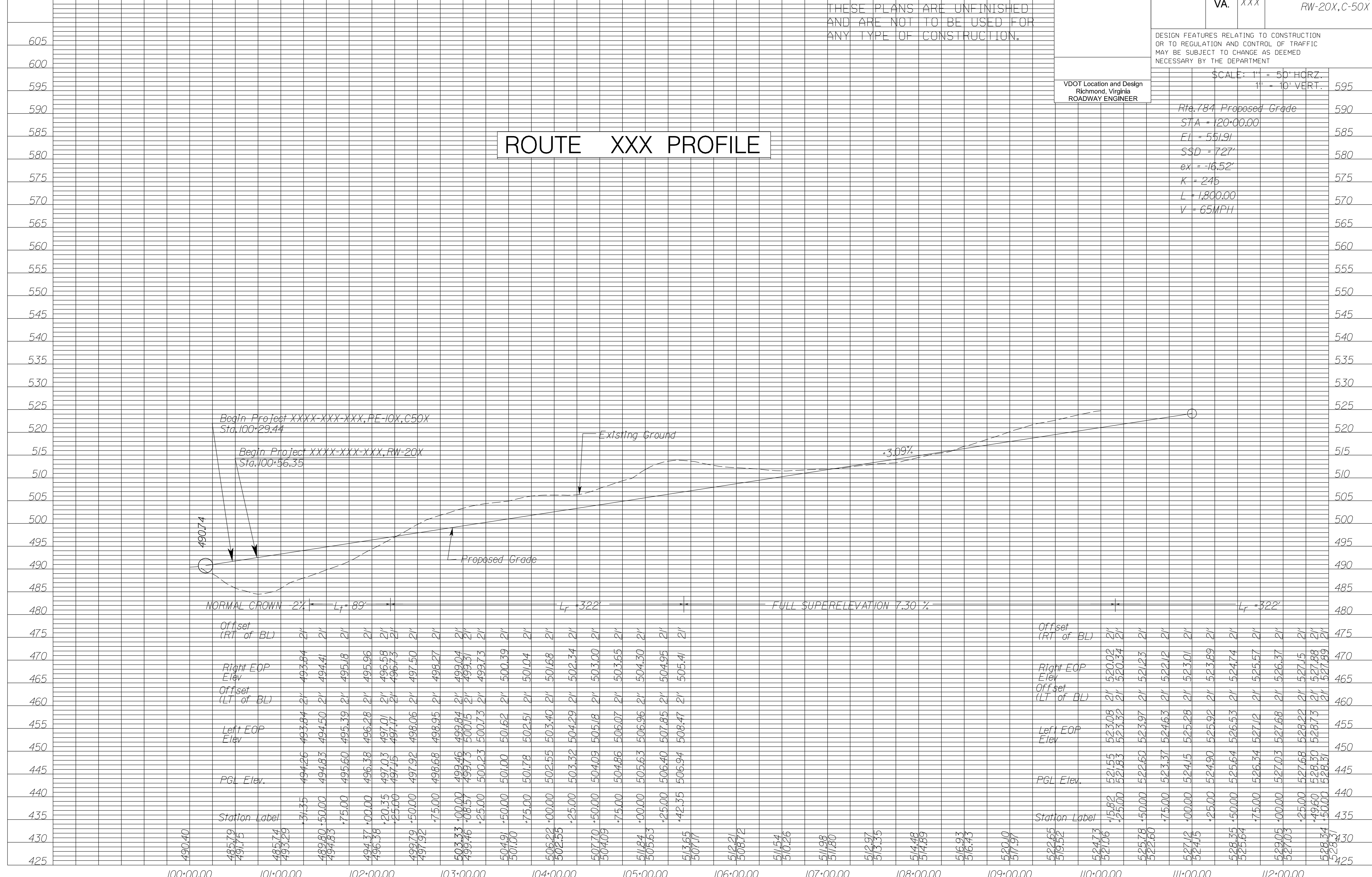

FIGURE 2H - 35 SAMPLE 1 PROFILE SHEET

9/5/2014
8:39:52 AM

Profile Sheet (2).dgn
Plotted By: stewart.williams

SURVEYED BY _____
SUPERVISED BY _____
DESIGNED BY _____

DESIGN FEATURES RELATING TO CONSTRUCTION OR TO REGULATION AND CONTROL OF TRAFFIC MAY BE SUBJECT TO CHANGE AS DEEMED NECESSARY BY THE DEPARTMENT

REVISED	STATE	FEDERAL AID PROJECT	ROUTE	STATE PROJECT	SHEET NO.
	VA.		XXX	XXXX-XXX-XXX,C-50X	5A

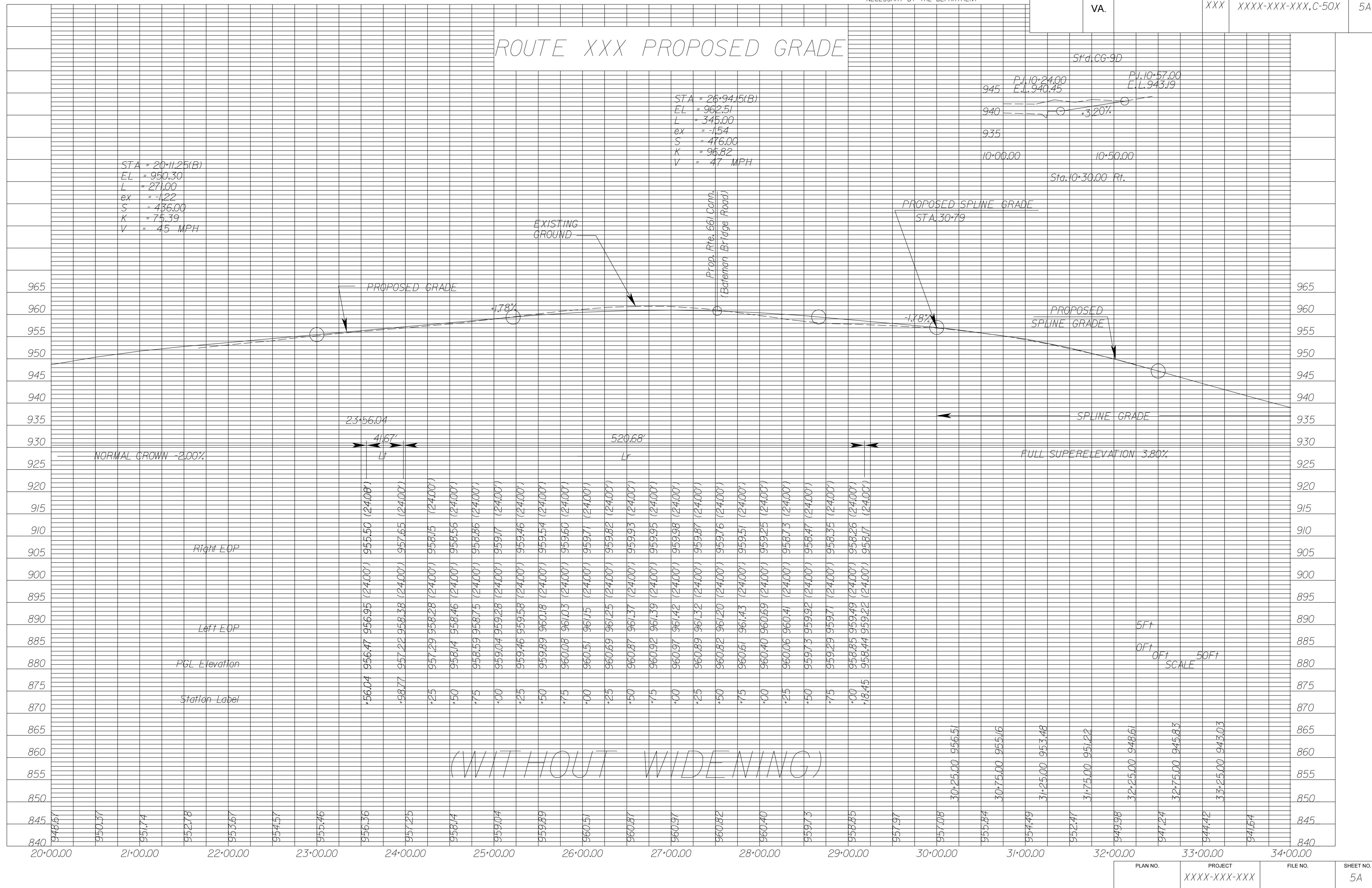

938.93

PLAN NO.	PROJECT	FILE NO.	SHEET NO.
	XXXX-XXX-XXX		5A

FIGURE 2H - 36 SAMPLE 2 PROFILE SHEET

9/5/2014
8:41:33 AM

Profile Sheet (3.dgn)
Plotted By: stewartwills

PROJECT MANAGER _____
SURVEYED BY, DATE _____
DESIGN BY _____
SUBSURFACE UTILITY BY, DATE _____

REVISED	STATE	ROUTE	STATE PROJECT	SHEET NO.
	VA.	XXX	XXXX-XXX-XXX, RW-20X,C-50X	7A

DESIGN FEATURES RELATING TO CONSTRUCTION OR TO REGULATION AND CONTROL OF TRAFFIC MAY BE SUBJECT TO CHANGE AS DEEMED NECESSARY BY THE DEPARTMENT

VDOT Location and Design
Richmond, Virginia
ROADWAY ENGINEER

ROUTE XXX PROFILE

THESE PLANS ARE UNFINISHED AND ARE NOT TO BE USED FOR ANY TYPE OF CONSTRUCTION.

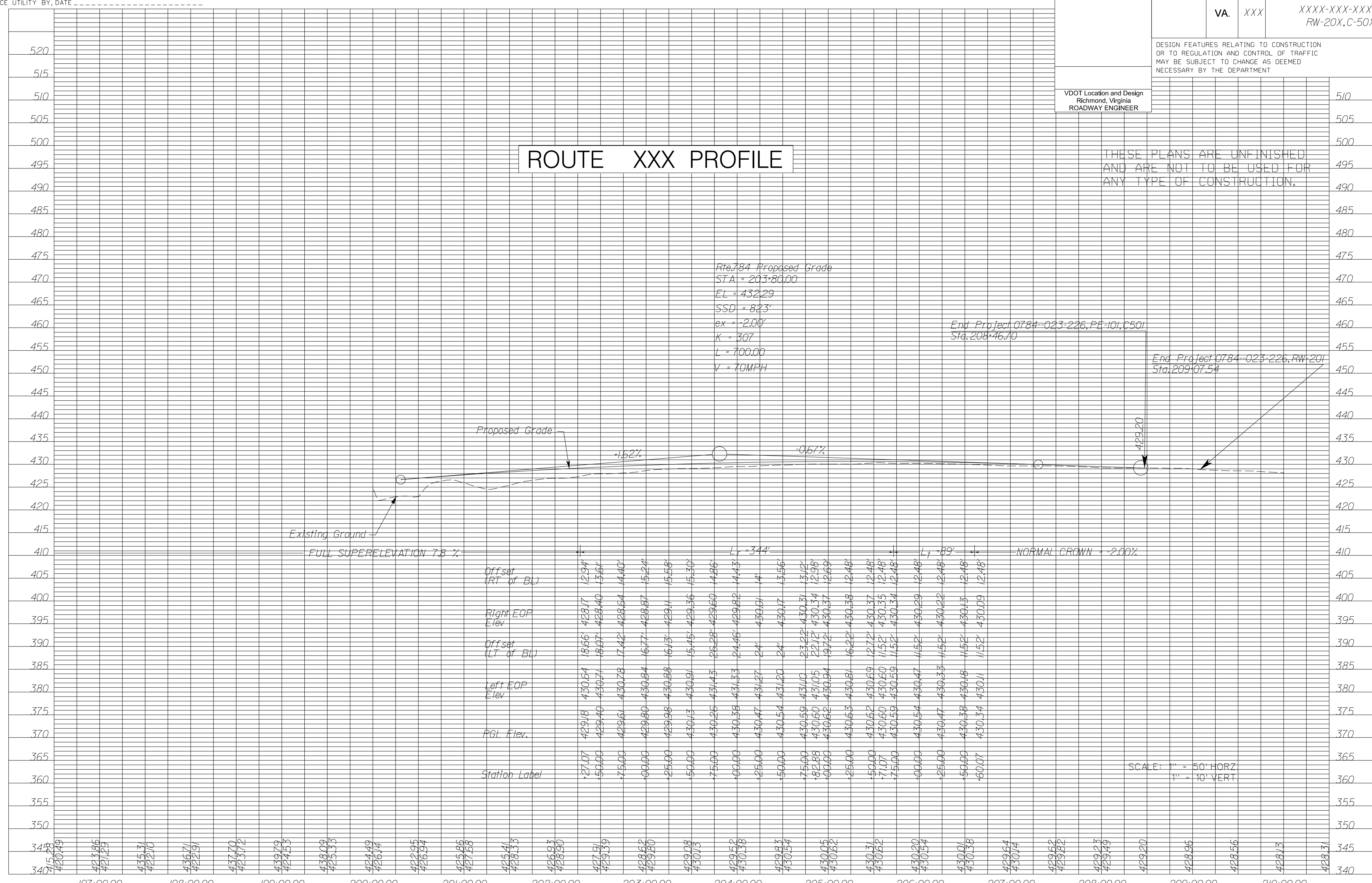

Cell Revised 12/11/12

FIGURE 2H - 37 SAMPLE 3 PROFILE SHEET

9/5/2014
9:23:35 AM

Drainage Description Sheet
Plotted By: stewartwillis

SURVEYED BY _____
SUPERVISED BY AAA
DESIGNED BY BBB

DESIGN FEATURES RELATING TO CONSTRUCTION OR TO REGULATION AND CONTROL OF TRAFFIC MAY BE SUBJECT TO CHANGE AS DEEMED NECESSARY BY THE DEPARTMENT

REVISED	STATE	FEDERAL AID PROJECT	STATE		SHEET NO.
			ROUTE	PROJECT	
	VA.		XXX	XXXX-XXX-XXX, RW-20X, C-50X	3B

DRAINAGE DESCRIPTION

SHEET 3

- 3-1 1 - St'd, DI-3A Req'd. (precast)
H=1.22m Inv.10.50
- 3-1 4-10 53m - 0.375m Conc. Pipe Req'd. (0.8m cover)
Inv.(in) 10.50 Inv.(out) 10.15

SHEET 4

- 4-1 1 - St'd, DI-3B Req'd. L=1.8m (precast)
H=1.20 Inv.9.40
- 4-1a 2.89m - St'd, MH-1 or MH-2 Req'd.
Inv.7.52 St'd, IS-1 Req'd.
1 - St'd, MH-1 Frame & Cover Req'd.
- 4-1 4-1a 1m - 0.375m Conc. Pipe Req'd. (0.8m cover)
Inv.(in) 9.40 Inv.(out) 9.39
- 4-1a 5-8a 49m - 0.60m Conc. Pipe Req'd. (2.7m cover)
Inv.(in) 7.52 Inv.(out) 7.17
- 4-2 1 - St'd, DI-3A Req'd. (precast)
H=1.20 Inv.9.85
- 4-2 4-13 1m - 0.375m Conc. Pipe Req'd. (0.8m cover)
Inv.(in) 9.85 Inv.(out) 9.84
- 4-13 4-1a 73m - 0.60m Conc. Pipe Req'd. (2.5m cover)
Inv.(in) 8.05 Inv.(out) 7.55
- 4-3 1 - St'd, DI-3A Req'd. (precast)
H=1.20 Inv.10.00
- 4-3 4-12 1m - 0.375m Conc. Pipe Req'd. (0.8m cover)
Inv.(in) 10.00 Inv.(out) 9.99
- 4-12 4-13 16m - 0.60m Conc. Pipe Req'd. (2.5m cover)
Inv.(in) 8.15 Inv.(out) 8.08
- 4-4 1 - St'd, DI-3A Req'd. (precast)
H=1.20 Inv.10.25
- 4-4 4-4a 1m - 0.375m Conc. Pipe Req'd. (0.8m cover)
Inv.(in) 10.25 Inv.(out) 10.24
- 4-4a 2.98m - St'd, MH-1 or MH-2 Req'd.
Inv.8.27 St'd, IS-1 Req'd.
1 - St'd, MH-1 Frame & Cover Req'd.
- 4-4a 4-12 23m - 0.60m Conc. Pipe Req'd. (2.3m cover)
Inv.(in) 8.27 Inv.(out) 8.15
- 4-5 1 - St'd, DI-3B Req'd. L=1.2m (precast)
H= 1.21m Inv.10.30
- 4-5 4-11 1m - 0.375m Conc. Pipe Req'd. (0.8m cover)
Inv.(in) 10.30 Inv.(out) 10.29
- 4-11 4-4a 19m - 0.60m Conc. Pipe Req'd. (2.3m cover)
Inv.(in) 8.37 Inv.(out) 8.30
- 4-6 1 - St'd, DI-3B Req'd. L=1.8m (precast)
H= 1.43m Inv.9.05 St'd, IS-1 Req'd.
- 4-6 5-14 42.5m - 0.60m Conc. Pipe Req'd. (0.9m cover)
Inv.(in) 9.05 Inv.(out) 8.84
- 4-7 1 - St'd, DI-3B Req'd. L=1.2m (precast)
H= 1.33m Inv.9.29 St'd, IS-1 Req'd.
- 4-7 4-6 23m - 0.450m Conc. Pipe Req'd. (0.9m cover)
Inv.(in) 9.29 Inv.(out) 9.17
- 4-8 1 - St'd, DI-3B Req'd. L=1.8m (precast)
H= 1.30m Inv.9.55 St'd, IS-1 Req'd.

- 4-8 4-7 42m - 0.450m Conc. Pipe Req'd. (0.8m cover)
Inv.(in) 9.55 Inv.(out) 9.32

- 4-9 1 - St'd, DI-3B Req'd. L=1.2m (precast)
H= 1.20m Inv.9.80 St'd, IS-1 Req'd.

SHEET 4 (CONTINUED)

- 4-9 4-8 23m - 0.375m Conc. Pipe Req'd. (0.9m cover)
Inv.(in) 9.80 Inv.(out) 9.65
- 4-10 1 - St'd, DI-3B Req'd. L=1.2m (precast)
H= 1.22m Inv.10.13 St'd, IS-1 Req'd.
- 4-10 4-9 51m - 0.375m Conc. Pipe Req'd. (0.8m cover)
Inv.(in) 10.13 Inv.(out) 9.80
- 4-11 3m - St'd MH-1 or MH-2 Req'd.
Inv.8.37 (connect to exist. pipes)
1 - St'd MH-1 Frame & Cover Req'd. St'd, IS-1 Req'd.
- 4-12 2.87m - St'd MH-1 or MH-2 Req'd.
Inv.8.15 (connect to exist. 0.38m pipe)
1 - St'd MH-1 Frame & Cover Req'd. St'd, IS-1 Req'd.
- 4-13 2.89m - St'd MH-1 or MH-2 Req'd.
Inv.8.05 (connect to exist. 0.30m pipe)
1 - St'd MH-1 Frame & Cover Req'd. St'd, IS-1 Req'd.

SHEET 4C

- 4C-2 4C-1 12m - DBL 1.20m Conc. Pipe Req'd. (0.8m cover)
Inv.(in) 7.40 Inv.(out) 7.30 2-St'd, EW-7S Req'd.
35 m.Tons Erosion Control Stone Class 1, St'd, EC-1 Placement
Excavate 0.75m and Backfill with
72 M. Tons (0.6 m depth) No.3 Stone
Cap with 18 M. Tons (0.15 m depth) Bedding Mat'l, Aggr.No.25 or 26
Extend Bedding Mat'l, Aggr.No.25 or
26 as Class 1 Backfill per 2001
PB-I Standards, 80 M.Tons Req'd
24 Square Meters Geotextile (Embankment Stabilization) Fabric Req'd.
61 Cubic Meters Minor Structure Excavation
1-Dewatering Basin Req'd.

SHEET 5

- 5-2 5B-1 83m - St'd, 213m x 1.82m BD015 Req'd.
Inv.(in) 6.52 Inv.(out) 6.30
4 - St'd, BW-21 Req'd.
10 deg. Inlet & 5 deg. outlet skew, Debris Rack Req'd at Inlet end.
Excavate 1.0 m and Backfill with
1205 M.Tons Bedding Mat'l, Aggr. No. 25 or 26
3482 Cubic Meters Minor Structure Excavation
107 Metric Tons Erosion Control Stone Class 1 Req'd.
St'd, EC-1 Placement 1-Dewatering Basin Req'd.
Sleeve exist. san. sewer thru box, see sheet 16(5)
St'd, HR-1 on Wingwalls & Headwalls Req'd.
(connect to exist. 375mm pipe)
See Sheet 16(25) for Waterline Crossing Details
- 5-3 1 - St'd, DI-3AA Req'd.
H= 3.01m Inv.6.99 St'd, IS-1 Req'd.
- 5-3 Box 28.5m - 0.60m Conc. Pipe Req'd. (2.4m cover)
Inv.(in) 6.99 Inv.(out) 6.81 (tie into proposed box culvert)
- 5-4 1 - St'd, DI-3AA Req'd. (precast)
H= 2.69m Inv.7.20 St'd, IS-1 Req'd.
- 5-4 5-3 36m - 0.60m Conc. Pipe Req'd. (2.4m cover)
Inv.(in) 7.20 Inv.(out) 7.02

- 5-5 1 - St'd, DI-3AA Req'd. (precast)
H= 2.44m Inv.7.40 St'd, IS-1 Req'd.
- 5-5 5-4 35m - 0.60m Conc. Pipe Req'd. (2.0m cover)
Inv.(in) 7.40 Inv.(out) 7.23
- 5-6 5-5 16m - 0.60m Conc. Pipe Req'd. (1.8m cover)
Inv.(in) 7.50 Inv.(out) 7.40
- 5-6 1 - St'd, DI-3C Req'd. L=1.8m (precast)
H= 2.34m Inv.7.50 St'd, IS-1 Req'd.
- 5-7 1 - St'd, DI-3AA Req'd. (precast)
H= 3.34m Inv.6.91
1 - St'd, SL-1 Req'd. St'd, IS-1 Req'd.
- 5-7 Box 15m - 0.60m Conc. Pipe Req'd. (2.7m cover)
Inv.(in) 6.91 Inv.(out) 6.81 (tie into proposed box culvert)
- 5-8 1 - St'd, DI-3BB Req'd. L=1.8m (precast)
H= 3.25m Inv.7.04
1 - St'd, SL-1 Req'd. St'd, IS-1 Req'd.
- 5-8 5-7 15m - 0.60m Conc. Pipe Req'd. (2.7m cover)
Inv.(in) 7.04 Inv.(out) 6.94

SHEET 5 (CONTINUED)

- 5-8a 3.06m - St'd, MH-1 or MH-2 Req'd.
Inv.7.14
1 - St'd, MH-1 Frame & Cover Req'd. St'd, IS-1 Req'd.
- 5-8a 5-8 12.5m - 0.60m Conc. Pipe Req'd. (2.4m cover)
Inv.(in) 7.14 Inv.(out) 7.07
- 5-9 1 - St'd, DI-4B Req'd. L=1.8m (precast)
H= 2.40m Inv.7.65 St'd, IS-1 Req'd.
- 5-9 Box 27m - 0.90m Conc. Pipe Req'd. (2.2m cover)
Inv.(in) 7.65 Inv.(out) 6.98
Excavate 0.6m and Backfill with
83 M.Tons Bedding Mat'l, Aggr.No.25 or 26
(tie into proposed box culvert)
54 Square Meters Geotextile (Embankment Stabilization) Fabric Req'd.
- 5-10 1 - St'd, DI-4B Req'd. L=1.8m (precast)
H= 2.20m Inv.7.73 St'd, IS-1 Req'd.
- 5-10 5-9 32m - 0.90m Conc. Pipe Req'd. (1.5m cover)
Inv.(in) 7.73 Inv.(out) 7.68
Excavate 0.6m and Backfill with
98 M.Tons Bedding Mat'l, Aggr.No.25 or 26
64 Square Meters Geotextile (Embankment Stabilization) Fabric Req'd.
- 5-11 1 - St'd, DI-4A Req'd. (precast)
H= 2.10m Inv.7.76 St'd, IS-1 Req'd.
- 5-11 5-10 22.5m - 0.90m Conc. Pipe Req'd. (1.3m cover)
Inv.(in) 7.76 Inv.(out) 7.73
Excavate 0.6m and Backfill with
69 M.Tons Bedding Mat'l, Aggr.No.25 or 26
45 Square Meters Geotextile (Embankment Stabilization) Fabric Req'd.
- 5-12 1 - St'd, DI-4C Req'd. L=2.4m (precast)
H= 1.94m Inv.7.83 St'd, IS-1 Req'd.
- 5-12 5-11 27.5m - 0.90m Conc. Pipe Req'd. (1m cover)
Inv.(in) 7.83 Inv.(out) 7.79
Excavate 0.6m and Backfill with
85 M.Tons Bedding Mat'l, Aggr.No.25 or 26
55 Square Meters Geotextile (Embankment Stabilization) Fabric Req'd.

PLAN NO.	PROJECT	FILE NO.	SHEET NO.
	XXXX-XXX-XXX		3B

FIGURE 2H - 38 SAMPLE DRAINAGE DESCRIPTION SHEET

9/5/2014
10:36:29 AM

RWPlanSheet.dgn
Plotted By: stewartjillis

PROJECT MANAGER _____
SURVEYED BY _____
DESIGN SUPERVISED BY _____
DESIGNED BY _____

CURVE DATA

CHICKEN CITY RD
Curve CHICK-1
PI = 114+15.75
DELTA = 19° 56' 32.87" (LT)
D = 17' 12.2"
T = 58.54'
L = 115.90'
R = 333.00'
PC = 113+57.20
N = 595,607.734
E = 4,184,210.247
PT = 114+73.11
N = 595,694.089
E = 4,184,286.678
e = NC
V = 30mph

CURVE	DELTA	RADIUS	ARC	TANGENT	CH. BEARING	CHORD
1	19° 56' 33"	313.00'	108.94'	55.03'	N 4° 30' 4" E	108.39'
2	08° 04' 08"	353.00'	49.71'	24.90'	N 35° 34' 28" E	49.67'

Parcel #	R/W Take	Perm. Drainage Easement	Temp. Construction Easement
003	4129 Sq. Ft	871 Sq. Ft	1307 Sq. Ft
004	8712 Sq. Ft	1812 Sq. Ft	
005	2265 Sq. Ft	765 Sq. Ft	
006	808 Sq. Ft	765 Sq. Ft	
007	2529 Sq. Ft		
008	1832 Sq. Ft		
009	1246 Sq. Ft		
010	1725 Sq. Ft		

MONUMENT	NORTH	EAST	ELEV
190-0994	595,804.100	4,184,427.152	15.564
190-0996	595,572.778	4,184,166.381	17.826
190-0998	595,748.429	4,184,363.169	16.013

SYMBOL LEGEND
■ Proposed R/W Monument

NOTES:

1. THIS RIGHT OF WAY SHEET REPRESENTS A FIELD RUN PERIMETER SURVEY OF THE PROPOSED R/W LIMITS. ALL OTHER ADJOINING/DEPARTING BOUNDARY LINES SHOWN ARE COMPILED FROM VARIOUS SOURCES: FOUND FIELD MONUMENTATION, METES AND BOUNDS DESCRIPTIONS, AND RECORDED PLATS. THE ADJOINING LINES DO NOT REPRESENT A FIELD RUN SURVEY OF THE ADJOINING PROPERTIES AND ARE A BEST FIT BASED ON COMPILED DATA. ALL AREAS SHOWN FOR R/W TAKES AND EASEMENTS ARE APPROXIMATE ONLY.
2. ALL OF THE PROPERTIES PHYSICAL IMPROVEMENTS ARE NOT SHOWN HEREON.
3. THIS PLAN SHEET WAS PERFORMED WITHOUT THE BENEFIT OF A TITLE REPORT AND MAY NOT SHOW ALL EASEMENTS WHICH MAY AFFECT THE PROPERTY SHOWN HEREON.
4. NO DESIGNATION OR LOCATION OF SUBSURFACE UTILITIES WAS PERFORMED DURING PREPARATION OF THIS PLAN SHEET.
5. THIS SURVEY DATUM IS BASED ON VDOT PROJECT * U000-190-109, R-201, UPC * 12345.
6. ALL MONUMENTATION TO BE SET UPON COMPLETION OF CONSTRUCTION.
7. NO CEMETERY SITES WERE OBSERVED ON THE SUBJECT PROPERTY. THIS DOES NOT PRECLUDE THEIR EXISTENCE.

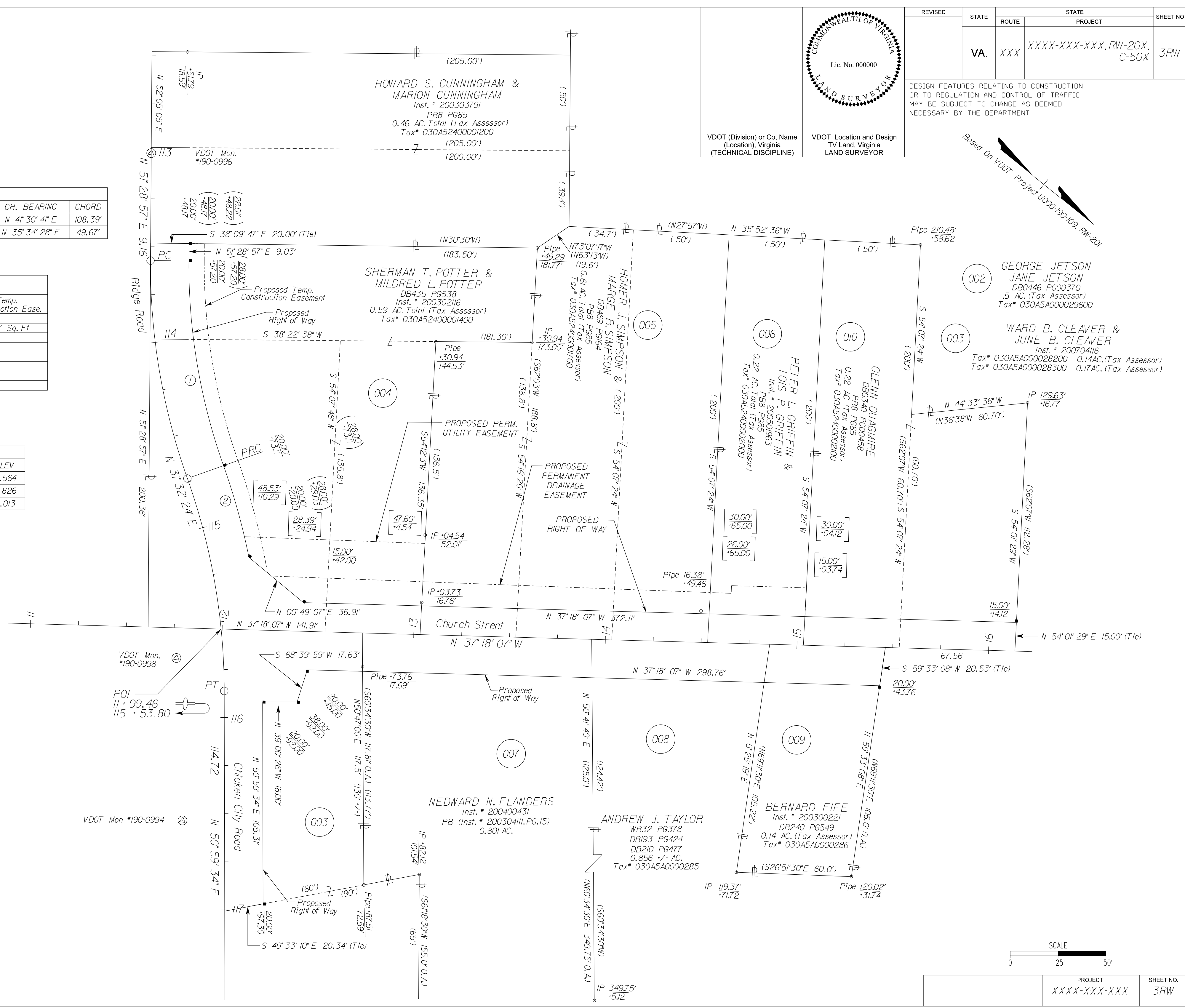

	REVISION	STATE	ROUTE	STATE PROJECT	SHEET NO.
		VA	XXX	XXXX-XXX-XXX, RW-20X, C-50X	3RW
DESIGN FEATURES RELATING TO CONSTRUCTION OR TO REGULATION AND CONTROL OF TRAFFIC MAY BE SUBJECT TO CHANGE AS DEEMED NECESSARY BY THE DEPARTMENT					
VDOT (Division) or Co. Name (Location), Virginia (TECHNICAL DISCIPLINE)	VDOT Location and Design TV Land, Virginia LAND SURVEYOR				

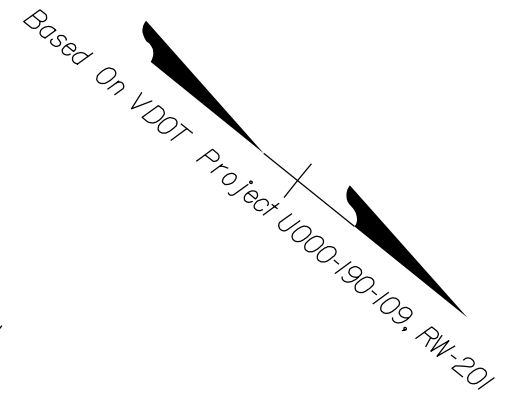

FIGURE 2H - 39 SAMPLE RIGHT OF WAY PLAN SHEET

9/5/2014
9:49:06 AM

d1346308.dgn
Plotted By: stewart.williams

PROJECT MANAGER _____
SURVEYED BY _____
DESIGN SUPERVISED BY _____
DESIGNED BY _____

REVISED	STATE	ROUTE	STATE PROJECT	SHEET NO.
	VA.	XXX	XXXX-XXX-XXX, RW-20X, C-50X	8

DESIGN FEATURES RELATING TO CONSTRUCTION OR TO REGULATION AND CONTROL OF TRAFFIC MAY BE SUBJECT TO CHANGE AS DEEMED NECESSARY BY THE DEPARTMENT

VDOT Location & Design
Richmond, Virginia
Roadway Engineer

ENTRANCE PROFILES

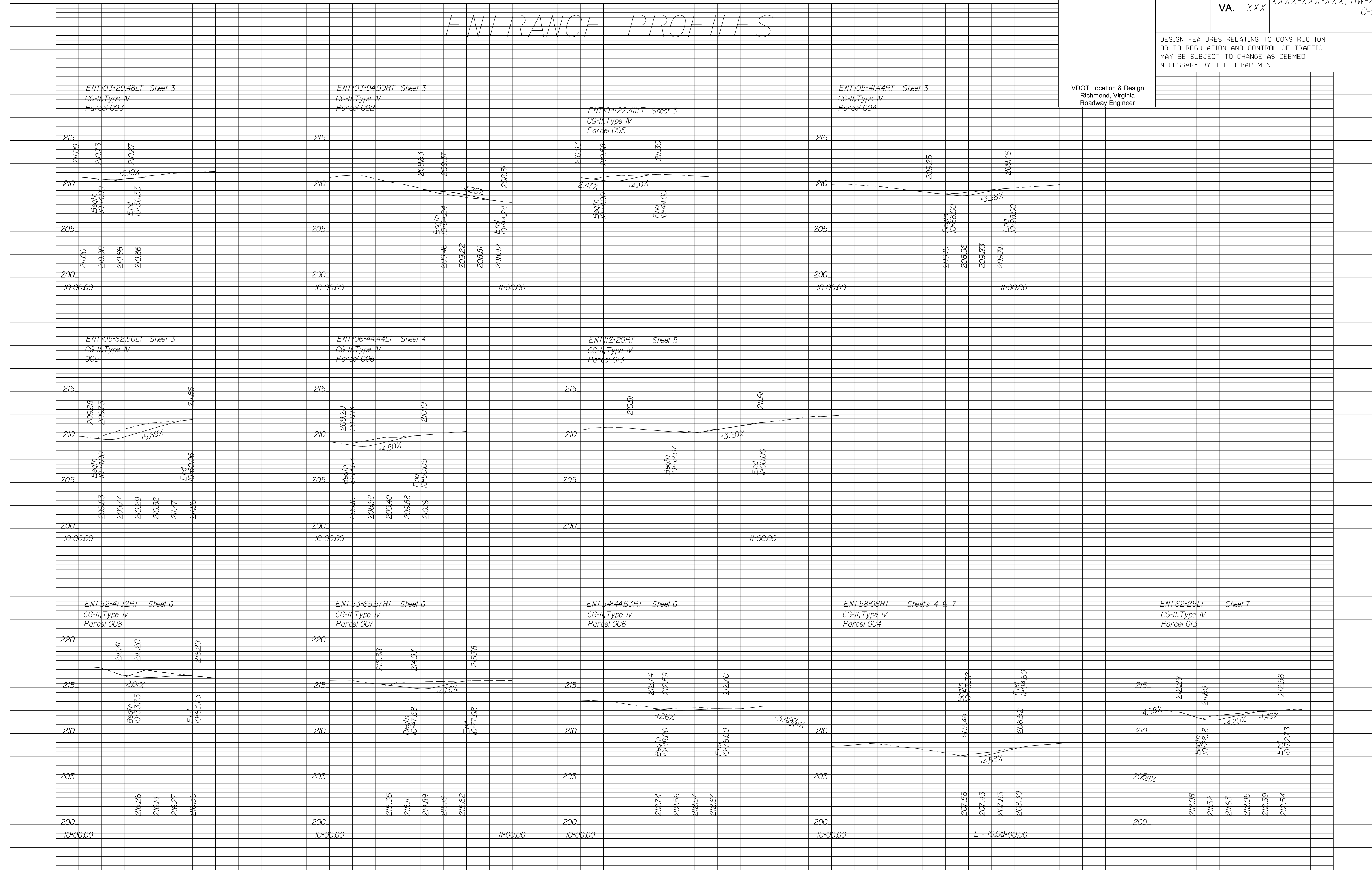

PROJECT	SHEET NO.
XXXX-XXX-XXX	8

FIGURE 2H - 40 SAMPLE ENTRANCE PROFILE SHEET