

**IMPERIAL ROAD DESIGN MANUAL**  
**REVISIONS July, 2013**

**CHAPTER 1B**

- Page 1D-13 – Added the following definitions;  
**Ramp:** *Includes all types, arrangements and sizes of turning roadways that connect two or more legs at an interchange. The components of a ramp include a terminal at each leg and a connecting road.*

**Ramp Proper:** *Includes the portion of the ramp that connects two terminals. The ramp proper begins or ends at the physical nose of the gore area or the functional intersection area.*

**Ramp Terminal:** *Includes the portion of the ramp that is adjacent to the through traveled way, including speed-change lanes (auxiliary lanes) and tapers. There are two basic designs for freeway ramp terminals: tapered and parallel.*

**CHAPTER 2E**

- Page 2E-13 – Revised the following language in the last paragraph from;  
*“St’d. CG-6 Curb and Gutter is to be specified unless design speeds require St’d. CG-7 (mountable curb) or a municipality specifically requests their own design and if so, the request is to be forwarded by Local Assistance Division to the State L&D Engineer for review and approval. In this case, details are to be shown on the typical sections and basis of payment to be municipality’s standard (example: Norfolk St’d. Curb and Gutter).”*

To:

*St’d. CG-6 or CG-7 Curb and Gutter is to be specified based on design speed or if guardrail is to be located at the face of curb. If a municipality requests the use of their own design, the request is to be forwarded by Local Assistance Division to the State L&D Engineer for review and approval. For a municipality’s own design, details are to be shown on the typical sections and the basis of payment is to be their standard; for example: Norfolk St’d. Curb and Gutter. However, whenever guardrail is to be placed at the face of curb instead of the applicable offsets, St’d. CG-7 shall be used.*

- Page 2E-20 – Revised the following language in the first sentence of the fifth paragraph  
from; “All limited access roadways will be fenced...”  
To; All limited access roadways “are required to” be fenced...

Deleted the following language after the sixth paragraph;

*“When it is recommended at the preliminary plan review not to fence the limited access line, each location is to be thoroughly discussed at the field inspection. Recommendations of these locations shall be included in the Field Inspection Report from the District Administrator and approved by the State Location and Design Engineer.”*

- Page 2E-21 – Deleted the following language;

***“TRAFFIC BARRIERS - GUARDRAIL AND CONCRETE BARRIERS***

*Traffic barriers are to be provided in accordance with the applicable "GR" or "MB" Standards and Appendix A (Section A-3 Traffic Barrier Installation Criteria).*

***SHY LINE***

*Shy line offset is defined as a distance beyond which a roadway object will not be perceived as a threat by a driver. In other words, a driver will not react to an object beyond the shy line offset. If possible, the roadside barrier should be placed beyond the shy line offset. See Appendix A (Section A-2 Clear Zone Guidelines).*

***CLEAR ZONE***

*Clear zone is defined as the roadside border area, starting at the edge of the through traveled way (edge of pavement), available for safe use by errant vehicles. Previously, 30 feet (9 m) was considered to be standard clear zone, but current guidelines in Appendix A Section A-2-CLEAR ZONE GUIDELINES and AASHTO's Roadside Design Guide give values greater or less than 30 feet (9 m), depending on the roadside slopes, operating speed, and traffic volumes.*

***RUN-ON TERMINALS***

*Guardrail terminals are to be provided for all installations, regardless of Functional Classification. The termini of guardrail must be designed and located so there are no exposed rail element ends on which a vehicle could be impaled.”*

This information can be found in Appendix “A”.

- Page 2E-22 – Deleted the following language;  
 “With *St'd. GR-2*, the preferred treatment is to bury the end of the guardrail, using the *St'd. GR-6* end treatment, into a cut slope even if the guardrail must be extended a short distance to accomplish this. If the use of *St'd. GR-6* treatment is not practical, the *St'd. GR-7* or *GR-9* is to be used. (See Section A-3 for further instructions).

*For concrete barriers the run-on terminals are to be buried into a cut slope where feasible. When it is impractical to bury the terminal, an approved impact attenuator or a section of guardrail with an approved transition and guardrail terminal is to be used. When operating speeds are below 40 mph (65 km/h), a turned down section of concrete barrier may be used. It will be necessary to review the location with the Standards/Special Design Section and, if approved, they will furnish design details.*

*Proposed guardrail is depicted on the plans similarly to existing guardrail, except that circles are to be shaded and lines are solid and somewhat heavier. Proposed concrete barrier is depicted by a series of parallel lines. See the CADD Manual and the cell library for existing & proposed guardrail cells.”*

- Page 2E-25 & 26 – Relocated the following language to Appendix “A”;  
***POLICY FOR CONSTRUCTION OF CONCRETE BARRIER & RETAINING WALLS ON SUPERELEVATIONS***

- *Concrete Barriers on roadway approaches should be designed with the same shape (K type) and angle of inclination as the parapet face and concrete median barriers on the bridge.*
- *The Standard GS-11 has a 7% algebraic difference for the shoulder break on the outside of a superelevated section. The bridge deck has a straight super between parapet walls making it necessary to spline the shoulder grade of the roadway to match the bridge deck slope. Under normal conditions, this can be accomplished by a 200’ transition.*

*The same principle would apply to the low side of the roadway. Should the superelevation of the bridge deck be less than the slope of the inside shoulder, then it would be necessary to spline the shoulder grade to match the bridge deck. The length of transition is to be obtained by using sound engineering practices.*

## ***PLANS***

- *When concrete barriers are tied into the bridge parapets and median, a general note will need to be included in the plans specifying:*

<i>“The Contractor is to transition the Concrete Barrier so that the face will align with the face of the bridge parapets and median.”</i>
--------------------------------------------------------------------------------------------------------------------------------------------

- *The roadway development is to be closely coordinated with bridge design in the approach area.*

## EXAMPLES

- *Bridge geometrics for concrete median barrier and parapet of the same shape (K Type) may be constructed:*
  - 1) *Vertically, or*
  - 2) *Perpendicular to the superelevated pavement*

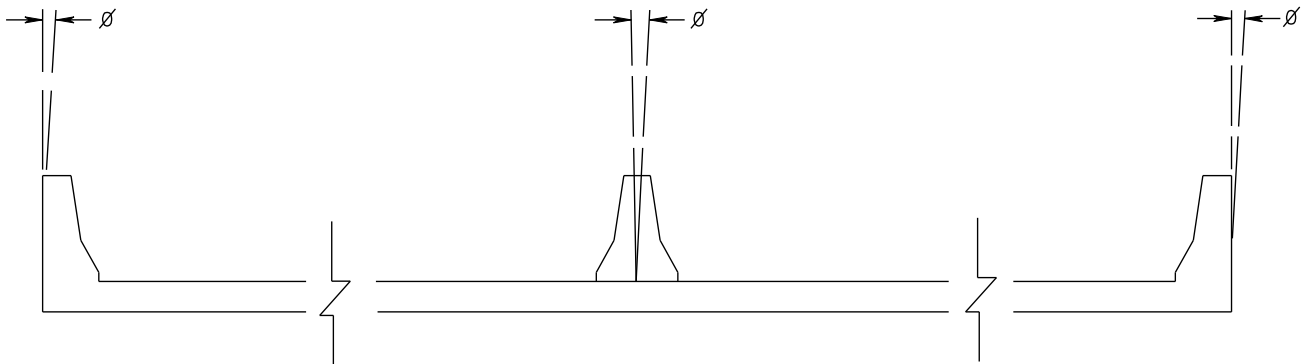

- *The barrier should be oriented vertically when the barrier is in front of a retaining wall, as illustrated below:*



- Page 2E-50 – Revised FIGURE 2E-9 DEPICTING LIMITED ACCESS RIGHT-OF-WAY to add the following language. “*Left turn lane tapers begin at the beginning and/or end of Limited Access Line.*” and “*100' Urban/300' Rural, measured from the Acceleration/Deceleration Lane Taper to the closest point (Turn Lane Taper/Entrance Flare) of Entrance.*”
- Page 2E-60 – Added the following language to the end of the third paragraph under “LAYOUT”; “*This identifies the horizontal location of a critical reference point on the project such as a road intersection, bridge or a well known landmark.*”

- Page 2E-68 – Deleted the following language;  
*Sheets which only pertain to Right of Way (i.e. R/W Data Sheet, Revision Data Sheet) are to be denoted with an asterisk as shown below:*

<i>SHEET NO. 1</i>	<i>TITLE SHEET</i>
<i>SHEET NO. 1A</i>	<i>PROJECT LOCATION MAP</i>
<i>SHEET NO. 1B</i>	<i>INDEX OF SHEETS</i>
<i>*SHEET NO. 1C</i>	<i>RIGHT OF WAY DATA SHEET</i>
<i>*SHEET NO. 1D</i>	<i>REVISION DATA SHEET</i>
<i>*SHEET NO. 1M</i>	<i>METES &amp; BOUNDS</i>

*\*Denotes sheets which are not to be printed for construction, but sheets shall be included in final set of construction plans stored in Falcon/Web Suite.*

## **CHAPTER 2F**

- Page 2F-5 – Revised title of the signee in the “APPROVED FOR RIGHT OF WAY” block from: “*CHIEF OF POLICY AND ENVIRONMENT*” To; “*CHIEF OF POLICY*”.
- Page 2F-11 – Added the following language at the end of “PROCESSING OF PLAN REVISION”; “*If a revision is made that affects any information on the Right of Way Data Sheet, then it must also be revised.*”
- Page 2F-12 – Added the following language at the end of the first paragraph under “INFORMAL REVISION-MINOR CHANGES”; “*If a revision is made that affects any information on the Right of Way Data Sheet, then it must also be changed.*”

## **APPENDIX “A”**

- Page A-2 – Added the following language after the second paragraph;  
*“For applicable projects, the following note shall be placed on the title sheet under the Functional Classification and Traffic Data Block: NOTE: THESE PLANS WERE DESIGNED IN ACCORDANCE WITH THE AASHTO GUIDELINES FOR GEOMETRIC DESIGN OF VERY LOW-VOLUME LOCAL ROADS (ADT ≤ 400).”*

- Page A-3 – Revised the following language in the second paragraph under “DESIGN SPEED” from; *“The geometric tables indicate a design speed range for each functional classification. The selection of the proper design speed to be used on a particular project is of primary importance in project development. The design speed selected should:”*

To;

The geometric tables indicate a design speed range, “*or a portion of a range,*” for each functional classification. “*The design speed range for each roadway classification is available in the AASTHO Green Book.*” The selection of the proper design speed to be used on a particular project is of primary importance in project development. The design speed selected should:

- Page A-6 – Added the following language under “LANE/PAVEMENT TRANSITIONS, MERGING TAPERS AND SPEED CHANGE LENGTHS: *“Source: 2009 MUTCD, Section 6”*,  
*NOTE:*

*A pavement transition length of 1/2L (calculate L by using the applicable formula above) is to be used when establishing project termini for the majority of small bridge replacement and/or major bridge rehabilitation projects when “NO” horizontal or vertical geometric changes are required to tie into the existing approach alignment.*

*Pavement transition is separate from the length of need for guardrail. Length of need and shoulder prep for guardrail shall be in accordance with the VDOT RDM Appendix A and the Road & Bridge Standards. See Volume 5 Part 2 of the Structure and Bridge Manual for additional applications.*

- Page A-7 – Added 45 MPH “Design Speed – Minimum Radius – Minimum Stopping Sight Distance” to the “Mountainous Terrain” in the GS-1 St’d.
- Page A-8 – Added 45 MPH “Design Speed – Minimum Radius – Minimum Stopping Sight Distance” to the “Mountainous Terrain” in all “Traffic Volume” in the GS-2 St’d.
- Page A-9 – Added Additional “Design Speed – Minimum Radius – Minimum Stopping Sight Distance” to the numerous “Terrains” in all “Traffic Volume” in the GS-3 St’d.
- Page A-10 – Added Additional “Design Speed – Minimum Radius – Minimum Stopping Sight Distance” to the numerous “Terrains” in all “Traffic Volume” in the GS-4 St’d.

Added “FOOTNOTE” No. 10 to the “Minimum Width of Ditch Front Slope” table that was inadvertently left out.

- Page A-11 – Added Additional “Design Speed – Minimum Radius – Minimum Stopping Sight Distance” to “Other Principal Arterial with Shoulder Design and Curb & Gutter” in the GS-5 St’d.

- Page A-12 – Added Additional “Design Speed – Minimum Radius – Minimum Stopping Sight Distance” to “Streets with Curb & Gutter and Shoulder Design” in the GS-6 St’d.
- Page A-13 – Added Additional “Design Speed – Minimum Radius – Minimum Stopping Sight Distance” to “Streets with Curb & Gutter and Shoulder Design” in the GS-7 St’d.
- Page A-14 – Added Additional “Design Speed – Minimum Radius – Minimum Stopping Sight Distance” to “Streets with Curb & Gutter and Shoulder Design” in the GS-8 St’d.
- Page A-15 – Added Additional “Design Speed – Minimum Radius – Minimum Stopping Sight Distance” to the “Geometric Design Standards for Service Roads (GS-9)”.
- Page A-16 – Added Additional “Design Speed – Minimum Radius – Minimum Stopping Sight Distance” to the “Geometric Design Standards for Interchange Ramps (GS-R)”.
- Page A-21 – Added the following language to the section title to; SECTION A-2 CLEAR ZONE”/LATERAL OFFSET” GUIDELINES

Added the following language in the first sentence under “INTRODUCTION”;

*The term “clear zone” is used to describe the unobstructed, traversable area provided beyond the edge of the “through” traveled way for the recovery of an errant vehicle.*

Deleted the following in the language third paragraph under “INTRODUCTION”;

*When establishing a full-width clear zone in an urban area is not practical due to right of way constraints, consideration should be given to establishing a reduced clear zone or incorporating as many clear zone concepts as practical such as removing roadside objects or making them crashworthy. The minimum requirement for this scenario is 1.5 ft. lateral offset.*

Replaced the following language under “ROADS WITH SHOULDERS” from:

*For all Freeways and Arterials, (and for Collectors with design speeds  $\geq 50$  mph) clear zone widths are to be determined from AASHTO’s Roadside Design Guide, Chapter 3. For an example, see Figure A-2-1, Case 1.*

*For all Rural Local Roads, Urban Local Streets with paved shoulders (and Collectors with design speeds  $\leq 45$  mph) as much clear zone as practical should be provided, with a minimum of 10’ beyond the traveled way. (See 2011 AASHTO A Policy on Geometric Design of Highways and Streets, Chapters 4 and 5). For an example, see Figure A-2-1, Case 2.*

*On projects such as RRR, intersection improvements, etc. recoverable areas are not always practical due to the intent of the project to provide minimal improvements, and extend the service life of the existing roadway, for a fraction of the costs of reconstruction. However, as much clear zone as practical should be provided.*

*Source: TRB Special Report 214, Designing Safer Roads*

*Whenever adequate right of way is available, urban projects should be designed with shoulders in lieu of curbs (unless city ordinances require otherwise) and clear zone widths should be consistent with the requirements for roadways with shoulders. (See 2011 AASHTO “A Policy on Geometric Design of Highways and Streets”, Chapter 7). The justification for providing a curb is to be documented in the project file (e.g. Preliminary Field Inspection Report, recommendation from Right of Way and Utilities Division, etc.).*

*In an urban environment, right of way is often extremely limited and in many cases it is not practical to establish a full width clear zone using the guideline in the Roadside Design Guide.*

To;

*In rural environments, where speeds are higher and constraints are fewer, a clear zone appropriate for the traffic volume, design speed, and facility type should be provided in accordance with the AASHTO Roadside Design Guide, Chapter 3. These values also are applicable for freeways and other controlled-access facilities in urban areas. For an example, see Figure A-2-1, Case 1.*

Whenever adequate right of way is available, urban projects should be designed with shoulders in lieu of curbs (unless city ordinances require otherwise) and clear zone widths should be consistent with the requirements for roadways with shoulders. (See 2011 AASHTO “A Policy on Geometric Design of Highways and Streets”, Chapter 7). The justification for providing a curb is to be documented in the project file (e.g. Preliminary Field Inspection Report, recommendation from Right of Way and Utilities Division, etc.).

For Rural Local Roads, Urban Local Streets with paved shoulders and Collectors with design speeds  $\leq 45$  mph, as much clear zone as practical should be provided, with a minimum of 10' beyond the traveled way. (See 2011 AASHTO A Policy on Geometric Design of Highways and Streets, Chapters 4, 5 and 6). For an example, see Figure A-2-1, Case 2.

On projects such as RRR, intersection improvements, etc. recoverable areas are not always practical due to the intent of the project to provide minimal improvements and extend the service life of the existing roadway for a fraction of the costs of reconstruction. However, as much clear zone as practical should be provided.

Sources: TRB Special Report 214, Designing Safer Roads / 2011 AASHTO A Policy on Geometric Design of Highways and Streets, Chapters 4-7 / 2011 AASHTO Roadside Design Guide



- Page A-22 – Replaced the following language under “ROADWAYS WITH CURBS” from:  
***High-Speed Roadways with curb***

*For roadways with design speeds of  $\geq 50$  mph, curb should ONLY be utilized in special situations. These situations may include, but are not limited to the following:*

- *Drainage considerations*
- *Need for access control*
- *Right of way restrictions*

*Source: AASHTO Green Book, Chapter 4*

*When necessary to utilize curb on a roadway with a design speed  $\geq 50$  mph for one of the situations listed above, the minimum lateral offset distance is 1.5 feet measured from the face of curb. However, consideration should be given to providing more than the minimum lateral offset to obstructions (signs, utility poles, luminaire supports, fire hydrants, etc. including breakaway devices), where practical, by placing fixed objects behind the sidewalk. See Figure A-2-1, Case 3.*

#### ***Low-Speed Roadways with curb***

*When curb is utilized on urban roadways with design speeds of  $\leq 45$  mph, the minimum lateral offset distance is 1.5 feet measured from the face of curb. See Figure A-2-1, Case 4.*

*When obstructions exist behind curbs, a minimum lateral offset of 3 feet should be provided beyond the face of curb to the obstruction at intersections and driveway openings. This offset provides sufficient clearance to keep the overhang of a truck from striking an object.*

To:

*“For urban arterials and other non-controlled access facilities in an urban environment, right of way is often extremely limited. In many cases, establishing a clear zone using the guidance in the Roadside Design Guide, Chapter 3 is not practical. These urban environments are characterized by sidewalks beginning at the face of the curb, enclosed drainage, numerous fixed objects (e.g. signs, utility poles, luminaire supports, fire hydrants, sidewalk furniture), and frequent traffic stops. These environments typically have lower operating speeds and in many instances, on-street parking. In these environments, a lateral offset to vertical obstructions (e.g. signs, utility poles, luminaire supports, fire hydrants,.) including breakaway devices, is needed to accommodate motorist operating on the highway.*

*When providing clear zone in accordance with the Roadside Design Guide in an urban area is not practical, consideration should be given to establishing as much lateral offset as practical, or incorporating as many clear-zone concepts as practical, such as removing roadside objects or making them crashworthy. Ideally, appurtenances (e.g. benches, trash*

barrels, bicycle racks) should be located as far away as practical, but at least 4 feet from the face of curb. Breakaway designs should be used for poles and appurtenances located less than 6 feet from the face of curb. See Figure A-2-1, Case 4.

Although the clear roadway concept is still the goal, many compromises are likely in urban or restricted environments. A minimum lateral offset of 1.5 feet shall be provided beyond the face of curb, with 3 feet minimum at intersections and driveway openings (10'–15' recommended, See *Roadside Design Guide*, Chapter 10). Note that this minimum lateral offset does not meet clear zone criteria but simply enables normal facility operations by providing clearance for turning trucks, etc. Consideration should be given to providing more than the minimum lateral offset to obstructions by placing fixed objects behind the sidewalk or sidewalk space. See Figure A-2-1, Case 2.

Note that curb is applicable to roadways with design speeds  $\leq 45$  mph and should be used on roadways  $> 45$  mph only in special situations. These situations may include, but are not limited to drainage considerations, a need for access control and right of way restrictions.

When a vertical drop-off or other hazard (see Section A-3, *Guardrail Warrants*) is located within 6' of the face of curb, guardrail should be considered. For instructions on the placement of guardrail adjacent to curb, see Section A-3, *Guardrail Installation in Urban Settings*. Contact the Location and Design Standards and Special Design Section for details.

Any fixed objects (signs, luminaire supports, large trees, etc.) located within a curbed median should not be located less than 6' from the face of curb. See Figure A-2-1, Case 5.

Source: AASHTO Green Book, Chapter 4 / *Roadside Design Guide*, Chapter 10”

- Page A-24 – Revised “Case 3 – Curb with Buffer Strip and Sidewalk” detail.
- Page A-25 – Revised “Case 4 – Curb with Sidewalk or Sidewalk Space” detail.

Added “Case 5 – Curbed Median” detail.

- Page A-29 – Revised the following language in the last sentence in the first paragraph from:  
“Following are typical methods of showing clear zone data on typical sections.” To:  
Following are typical methods of showing clear zone “/lateral offset” data on typical sections.

- Page A-31 – Revised the following language in the first paragraph from; *Embankment slopes from 3:1 up to 4:1 are considered traversable if they are smooth and free of fixed object hazards. However, since many vehicles on slopes this steep will continue on to the bottom, a clear run-out area beyond the toe of the slope is desirable. The extent of this recovery area could be determined by first finding the available distance between the edge of the traveled way and the breakpoint of the recoverable slope to the non-recoverable slope. This distance is then subtracted from the total recommended clear zone distance based on the slope that is beyond the toe of the non-recoverable slope. The result is the desirable clear run-out area. The following example illustrates this procedure:* To;  
*“Foreslopes” from 3:1 up to 4:1 are considered traversable if they are smooth and free of fixed object hazards. However, since many vehicles on slopes this steep will continue on to the bottom, a clear run-out area beyond the toe of the slope is desirable. The extent of this “clear run-out” area could be determined by first finding the available distance between the edge of the “through” traveled way and the breakpoint of the recoverable “foreslope” to the non-recoverable “foreslope.” This distance is then subtracted from the total recommended clear zone distance based on the slope that is beyond the toe of the non-recoverable “foreslope and should be at least 10’ if practicable.” The result is the desirable clear run-out area. The following example illustrates this procedure:*

Revised the following language in the next to the last paragraph from; *“Discussion: Using the steepest recoverable slope before or after the non-recoverable slope, a recovery distance is selected from Table A-2-1. In this example, the 8:1 slope beyond the base of the fill dictates a 30-32 foot recovery area. Since 17 feet is available at the top, an additional 13-15 feet could be provided at the bottom. All slope breaks may be rounded and no fixed objects would normally be built within the upper or lower portions of the clear zone or on the intervening slope.”* To;

Discussion: Using the steepest recoverable “foreslope” before or after the non-recoverable “foreslope, a clear zone” distance is selected from Table A-2-1. In this example, the 8:1 slope beyond the base of the fill dictates a 30-32 foot “clear zone” area. Since 17 feet is available at the top, an additional 13-15 feet could be provided at the bottom. “Since this is less than the 10’ recovery area that should be provided at the toe of all the non-recoverable slopes, the 10’ should be applied.” All “foreslope” breaks may be rounded and no fixed objects would normally be built within the upper or lower portions of the clear zone or on the intervening “foreslope.”

- Page A-35 – Added the following language after the second paragraph; *“Use of “aesthetic” guardrail is acceptable provided that it conforms to applicable VDOT Standards, NCHRP 350 and/or MASH requirements, and does not create undue maintenance problems and/or costs. An acceptable example is powder coated galvanized rail with treated wooden posts.”*
- Page A-36 – Added the following language to Table A-3-2;  
*“For permanent installations only; not to be used for TMP plans.”*

- Page A-37 – Replaced the following language in the forth second in the second paragraph under “GUARDRAIL INSTALLATION IN URBAN SETTINGS” from; “*For high-speed roadways with design speeds over 50 mph, guardrail is to be allowed with the face of curb...*” To; For high-speed roadways with design speeds over 50 mph, guardrail is to be “*aligned*” with the face of curb...
- Page A-47 & 48 – Relocated Concrete Barrier & Retaining Wall information on bridges from Chapter 2E. See 2E-25 -26 above.
- Page A-88 – Replaced the following language in the first second under “VDOT/AASHTO DESIGN GUIDELINES” from; *The following design guidelines are to assist in the design of bicycle facilities and have been obtained from AASHTO's 1999 "Guide for the Development of Bicycle Facilities" ....* To; The following design guidelines are to assist in the design of bicycle facilities and have been obtained from AASHTO's “2012” Guide for the Development of Bicycle Facilities”...
- Page A-94 – Replaced the following language in the third second under “Shoulder and Ditch Typical Section” from; “*When this is not possible and the distance between the outside edge of the graded shoulder and the shared use path is less than 5 feet, a suitable physical barrier is recommended.*” To; When this is not possible and the distance between the outside edge of the graded shoulder and the shared use path is less than 5 feet, a suitable physical barrier is “*required*”.
- Page A-95 – Replaced the following language last sentence on the page from; “*Under certain conditions it may be necessary or desirable to increase the width of a shared use path to 12 feet...*” To; Under certain conditions it may be necessary or desirable to increase the width of a shared use path to “*11*” feet...
- Page A-98 – Added the following language to the beginning of the second sentence under “Design Speed”; “*Design speeds range from 12 mph to 30 mph, as shown in Table A-5-7. However, in general...*”
- Page A-99 – Added the following language in the third sentence under “Grade”; The maximum grade of a shared use path adjacent to a roadway should be 5 percent, but the grade “*shall*” generally match the grade of the adjacent roadway. Where a shared use path runs “*adjacent to*” the roadway, grades may exceed 5 percent but “*shall*” be less than or equal to the roadway grade.

Added the following language after the first paragraph;  
*Grades on shared use paths in independent rights of way shall be limited to 5 percent maximum.*

*Grades steeper than 3 percent are not practical for shared use paths with crushed stone or other unpaved surfaces for both bicycle handling and drainage erosion reasons.*

*Options to mitigate excessive grades on shared use paths include the following:*

- Page A-102 – Revised FIGURE A-5-8 to agree with the AASHTO Bicycle Guide.
- Page A-103 – Deleted the following language in the second paragraph under “Path-Roadway Intersection”; “*This layout would be similar to the Typical Alternate Plan seen in VDOT’s CG-12 Standard.*”

## APPENDIX “B”

- Page B-41 – Added the following language and detail; *For Truck Apron Curb use cell Mod. CG3 found in the cell library.*

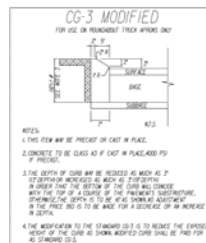

- Page B-42 – Replaced the “Roundabout Review Checklist” with the following;
  - *Design speed & fastest theoretical path*
  - *Design vehicle (WB-50 or WB-67)*
  - *Approach Grades/sight triangles/sight distances*
  - *Inscribed outer diameter of circulatory roadway*
  - *Apron composition, width, slope and curb standard*
  - *Circulatory lane width*
  - *Approach lane width/Deflection/radii*
  - *Departure lane width/Deflection/radii*
  - *Splitter island lengths/raised/flush*
  - *Pedestrian crossing locations/width, composition, raised/flush, markings.*
  - *Bicycle lane/approach & termination point.*
  - *Pavement markings (directional arrows, yield lines, edge lines, etc.)*
  - *Signing*
  - *Roadway Lighting (preferred)*
  - *Location of nearest entrances to outer inscribed diameter and nature of land use*
  - *Present & design year volumes/% trucks & turning movements on all approaches*
  - *AaSIDRA analysis on all approaches/peak hrs. LOS/queue lengths in design year*
  - *AUTO-TURN results of Design Vehicle for all turning movements.*
  - *Planting scheme/landscaping for mounded Center Island and splitter islands.*
  - *Proximity of roundabout to nearest traffic signal.*

## APPENDIX “B(1)”

- Page B(1) -21 – Added the following language to “Items C and D” headings; (*See Appendix C for more details*).

Added the following language to the end of the first sentence under Item C PARALLEL PARKING LANE WIDTHS; “*Provisions for on-street parallel parking are allowed on roadways where the posted speed limit is 35 mph or less.*”

- Page B(1)-43 – Deleted the following language under GUARDRAIL;  
*Guardrail shall be provided and installed by the developer as necessary for the safety of the traveling public as determined by the District Administrator’s Designee. Plans should indicate proposed guardrail location. Generally, when fill slopes are 3:1 or flatter, a barrier is not required unless there are hazardous obstacles within the clear zone limits. The developer is encouraged to examine alternatives that eliminate potential hazards in order to avoid the need for guardrail.*

*In urban and suburban settings with speeds of 45 mph or less that include curb or curb and gutter, the use of guardrail is not recommended. Standard CG-6 is normally used in these areas and is referred to as barrier curb because it has a 6” vertical face and is intended to discourage motorists from deliberately leaving the roadway, Even when mountable curb is used in suburban settings, it is impractical to install guardrail in an attempt to protect pedestrians walking along sidewalks due to the lack of accessibility caused when placing guardrail and terminals adjacent to accessible routes. Sometimes hazards, such as ponds or steep embankments, which need to be shielded, exist on subdivision streets with sidewalk/sidewalk space. In situations like this, guardrail can be placed behind the sidewalk.*

*The use of guardrail types that are aesthetically compatible with the surrounding areas should be considered. One acceptable type is "Corten" or weathering steel rail with treated timber post. Alternate types may be considered provided they (i) conform to applicable VDOT standards or the criteria prescribed in the National Cooperative Highway Research Program Report 350, (ii) blend in with their surroundings and (iii) do not create an undue maintenance problem. And replaced it as followed; “For design and application of guardrail, refer to Appendix A and the current VDOT Road and Bridge Standards.”*

- Page B(1)-51 – Added the following language and detail; *For Truck Apron Curb use cell Mod. CG3 found in the cell library.*

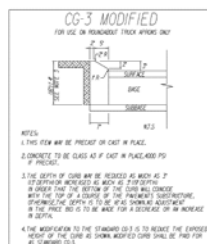

- Page B(1)-52 – Replaced the “Roundabout Review Checklist” with the following:
  - *Design speed & fastest theoretical path*
  - *Design vehicle (WB-50 or WB-67)*
  - *Approach Grades/sight triangles/sight distances*
  - *Inscribed outer diameter of circulatory roadway*
  - *Apron composition, width, slope and curb standard*
  - *Circulatory lane width*
  - *Approach lane width/Deflection/radii*
  - *Departure lane width/Deflection/radii*
  - *Splitter island lengths/raised/flush*
  - *Pedestrian crossing locations/width, composition, raised/flush, markings.*
  - *Bicycle lane/approach & termination point.*
  - *Pavement markings (directional arrows, yield lines, edge lines, etc.)*
  - *Signing*
  - *Roadway Lighting (preferred)*
  - *Location of nearest entrances to outer inscribed diameter and nature of land use*
  - *Present & design year volumes/% trucks & turning movements on all approaches*
  - *AaSIDRA analysis on all approaches/peak hrs. LOS/queue lengths in design year*
  - *AUTO-TURN results of Design Vehicle for all turning movements.*
  - *Planting scheme/landscaping for mounded Center Island and splitter islands.*
  - *Proximity of roundabout to nearest traffic signal.*
  
- Page B(1)-57 – Revised the following language in the third sentence in item “F” from;
 

Curb Extensions – Curb extensions at intersections are frequently used in Traditional Neighborhood Developments. Curb Extensions are usually found on higher volume streets where they are used to protect parking areas or reduce pedestrian crossing times. For intersections with curb extensions, a minimum 35’ radius should be used as in the sketch below. Intersection chokers or curb extensions can also be used to calm traffic and to shorten the distance pedestrians must travel to cross a street.

To;                    “*Curb Extensions – Curb extensions at intersections are frequently used in Traditional Neighborhood Developments. Curb Extensions are also used to protect parking areas and to reduce pedestrian crossing times.*”

Added the following language to the end of Item “F”

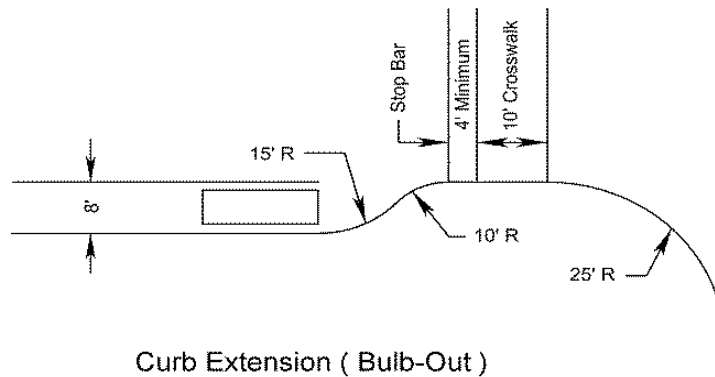

*Note: The sight distance triangle shall be free of any obstructions that block a driver's view of potential conflicting vehicles or pedestrians entering the traveled way. Examples of obstructions that limits sight distance include vehicles in adjacent lanes, parked vehicles, bridge piers and abutments, large signs, poorly pruned trees, tall shrubs and hedges, walls fences and buildings.*

## APPENDIX “C”

- Page C-2 – Replaced the following language in the first sentence under “PARKING SPACES” from; “Where parking spaces are provided, accessible spaces for persons with mobility impairments should comply with the following table:”

To; Where parking “is” provided “on the block perimeter and the parking spaces are marked or metered,” accessible spaces for persons with disabilities “shall” comply with the following table:

Replaced the following language to the “Source” of the total number of parking spaces to accessible spaces ratio table from; “Access Board Revised Draft Guidelines for Accessible Public Right of Way: Dated November 23, 2005.”

To; “Proposed Accessibility Guidelines for Pedestrians Facilities in the Public Rights of Way: Dated July 26, 2011”

Added the following under “SPARKING SPACES”;

“The MUTCD, Section 3B-19 contains provisions for marking parking spaces.

*Metered parking includes parking metered by parking pay stations. Where parking on part of the block perimeter is altered, the minimum number of accessible parking spaces required is based on the total number of marked or metered parking spaces on the block perimeter.*

*Accessible parking spaces shall be identified by signs displaying the International Symbol of Accessibility. Accessible parking spaces should be located where the street has the least crown and grade and close to key destinations.”*



*Parallel Parking Spaces (See Appendix B(1) for more details)*

*Parallel parking is the preferred arrangement for on-street parking.*

*Perpendicular or Angled Parking Spaces (See Appendix B(1) for more details)*

- Page C-4 – added the following language to FIGURE C-1-2 DESIGNS FOR PARALLEL PARKING SPACES EXCEPTION; “*Note: Corner clearance (i.e., the distance from the end of the intersection curb return to the nearest edge of on-street parking) should be at least 10 feet. If a traffic control device faces the parking channel, the distances should be 30 feet. Under all circumstances, on-street parking shall not be permitted where it will obstruct necessary sight distance.*”
- Page C-49 – Deleted the following language under “VI COMMENTS – A. DESIGN”; “*a. Minimum Standards of Entrances to State Highways, Mobility*”.
- Page C-80 & C-81 – Added the following language;

#### *SECTION C-8 RAMP TERMINAL AND SPEED CHANGE LANE DESIGNS*

### POLICY

The rate of accidents in gore areas is typically greater than that for run-off-the road accidents at other locations. For this reason, the gore area and the unpaved area beyond should be kept as free of obstructions as practicable to provide a clear recovery area. The unpaved area beyond the nose should be graded as nearly level with the roadways as is practicable so that vehicles inadvertently entering will not be upset or abruptly stopped by steep slopes. Heavy sign supports, street light standards, and roadway structure supports should be kept well out of the graded gore area. Yielding or breakaway-type supports should be employed for the standard exit sign, and concrete footings, where used, should be kept flush with adjoining ground level.

There will be situations where placement of a major obstruction in a gore is unavoidable. Gores that occur at exit ramp terminals on elevated structures are a prime example. There are occasions when a bridge pier in a gore cannot be avoided. Guardrails and bridge rails are designed to handle angular impacts but are not effective in handling the kind of near head-on impacts that occur at these gores.

Cushioning or energy-dissipating devices shall be provided in front of hazardous fixed objects. Several types and models of crash cushions are being used. These devices substantially reduce the severity of fixed-object accidents. In view of this reduction, adequate space should be provided for the installation of a crash-cushion device whenever it is found necessary to construct a major obstruction in a gore on a high-speed highway.

Tables in this section show **MINIMUM** designs for one lane of traffic and lengths may need to be increased based upon the traffic operational analysis. For two lanes or for other conditions see AASHTO's A Policy on Geometric Design of Highways and Streets. A design exception is required when design values are less than AASHTO minimums.

## PROCEDURES

Gore Area Design Details are to be furnished and included in the "2 series" plan detail sheets of the plan assembly at a recommended scale of approximately twice the plan scale. Gore Area design details shall show actual dimensions in accordance with details sheets provided below.

### Exit Ramps

- Interchange exit ramps are to be designed in accordance with details provided below. (Ref: AASHTO's A Policy on Geometric Design of Highways and Streets)
- Grading of the exit ramp gore area will be required to provide a recovery area for out-of-control vehicles. Unusual situations may require special handling of the slopes or the installation of an impact attenuation device; however, in no case will an earth berm be located in this area. All questions concerning individual designs should be discussed with the appropriate Assistant L&D Engineer.

### Entrance Ramps

- Entrance ramps are to be designed in accordance with the details provided below. Ref: AASHTO's A Policy on Geometric Design of Highways and Streets)

### Acceleration/Deceleration Lane Lengths and Grade Adjustments

- For lengths of Ramp Terminal Acceleration Lanes on flat grades (2 percent or less), see 2011 AASHTO Green Book, Table 10-3, page 10-110. Acceleration lane lengths on grades  $\geq 3\%$  must be adjusted in accordance with adjustment factors shown in the 2011 AASHTO Green Book, Table 10-4, page 10-112.
- For lengths of Ramp Terminal Deceleration Lanes on flat grades (2 percent or less), see 2011 AASHTO Green Book, Table 10-5, page 10-115. Deceleration lane lengths on grades  $\geq 3\%$  must be adjusted in accordance with adjustment factors shown in the 2011 AASHTO Green Book, Table 10-4, page 10-112.
- Lengths shown in the 2011 AASHTO Green Book are for single lane traffic. For two-lane ramps, or other conditions, consult the AASHTO Green Book for additional instructions.
- For Taper Lengths, see Table C-8-1 below:

- Page C-82 – Added “FIGURE C-8-1 RAMP GORE FOR EXIT RAMP”.
- Page C-83 – Added “FIGURE C-8-2 RAMP GORE FOR EXIST RAMP – TAPER TYPE”.
- Page C-84 – Added “FIGURE C-8-3 RAMP GORE FOR MAJOR FORK”.
- Page C-84 – Added “FIGURE C-8-4 RAMP GORE FOR ENTRANCE RAMP”.
- Page C-85 – Added “TABLE C-8-1 LENGTH OF TAPER FOR SPEED CHANGE LANES ON PARALLEL RAMPS”.

Added “TABLE C-8-2 MINIMUM LENGTH OF TAPER BEYOND OFFSET NOSE”.

## APPENDIX “F”

- Page F-27 – Added the following language at the end the of first paragraph; “*Note: For Limited Access Line and/or Fence Requirements, See Figures 2-9 and 2-10 in Chapter 2E of the Road Design Manual.*”
- Page F-35 – Revised the following language in TABLE 2-7 INTERSECTION SIGHT DISTANCE to revise the sight distance on SDL: (Where left turns are physically restricted) at 55mph from 560 ft. to 566 ft.
- Page F-36 – Added the following language to the forth sentence in the sixth paragraph to read; If the minimum intersection sight distance values in the table mentioned above cannot be met, “*including applying the adjustment factors for sight distances based on approach grades,*”...
- Page F-42 – Added the following language and detail; *For Truck Apron Curb use cell Mod. CG3 found in the cell library.*

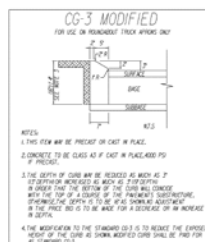

- Page F-44 – Replaced the “Roundabout Review Checklist” with the following;
  - *Design speed & fastest theoretical path*
  - *Design vehicle (WB-50 or WB-67)*
  - *Approach Grades/sight triangles/sight distances*
  - *Inscribed outer diameter of circulatory roadway*
  - *Apron composition, width, slope and curb standard*
  - *Circulatory lane width*
  - *Approach lane width/Deflection/radii*
  - *Departure lane width/Deflection/radii*
  - *Splitter island lengths/raised/flush*
  - *Pedestrian crossing locations/width, composition, raised/flush, markings.*
  - *Bicycle lane/approach & termination point.*
  - *Pavement markings (directional arrows, yield lines, edge lines, etc.)*
  - *Signing*
  - *Roadway Lighting (preferred)*
  - *Location of nearest entrances to outer inscribed diameter and nature of land use*
  - *Present & design year volumes/% trucks & turning movements on all approaches*
  - *AaSIDRA analysis on all approaches/peak hrs. LOS/queue lengths in design year*
  - *AUTO-TURN results of Design Vehicle for all turning movements. Planting scheme/landscaping for mounded Center Island and splitter islands.*
  - *Proximity of roundabout to nearest traffic signal.*
  
- Page F-54 – Added the following language at the bottom of the page; “Source: 2009 MUTCD, Section 6.”
  
- Page F-75 – Added the following language at the top of the page: “Acceleration lanes shall be considered on high speed roadways where WB 62 vehicles will be entering the roadway.”

Added the following language at the end of the page:

***Deceleration Lanes***

- *Storage and Transition Taper: See Section 3 – Turning Lanes, Figure 3-1 Left and Right Turn Lanes Criteria in this chapter.*
  
- Page F-89 – Replaced the following language in the first paragraph from; “AASHTO does not present guidelines as to the size of the functional area of an intersection; however the size must be much larger than the physical area (see Figure 4-2A). The functional area should be composed of the distance traveled during the braking Perception-Reaction Time plus the distance required to move laterally and come to a stop plus any required storage length (see Figure 4-3). The minimum maneuver distance assumes that the driver is in the proper lane and only needs to move laterally into a right turn or left turn bay.”  
To;  
 “The functional area on the approach to an intersection consists of three basic elements: perception-reaction decision distance, maneuver distance, and queue-storage distance.”

*These elements are identified in Figure 4-3. The distance traveled during the perception-reaction time will depend on such factors as vehicle speed. Where there is a left or right turn lane, the maneuver distance includes the length needed for both braking and lane changing. In the absence of turn lanes, it involves braking to a comfortable stop. The storage length should be sufficient to accommodate the longest queue expected most of the time.”*

Replaced FIGURE 4-3 FUNCTIONAL AREA OF INTERSECTION with revised detail and renamed to FIGURE 4-3 ELEMENTS OF THE FUNCTIONAL AREA OF INTERSECTION.