

CHAPTER 2E - PHASE III, FIELD INSPECTION

SECTION 2E – 1 - SOIL SURVEY AND PAVEMENT DESIGN

	Page
SOIL SURVEY AND PAVEMENT DESIGN RECEIVED.....	2E-1
RESOLUTION OF BORROW / SURPLUS AND UNSUITABLE MATERIAL ...	2E-1

SECTION 2E – 2 - DETAILED DRAINAGE DESIGN

	Page
DESIGNING DRAINAGE.....	2E-7
DEPICTING DRAINAGE ON PLANS	2E-7
NON-STANDARD ROADSIDE DITCHES	2E-8
END SECTIONS FOR PIPE CULVERTS	2E-9
PIPE ENDWALLS WITH LOAD CARRYING GRATE.....	2E-10
REMOVAL OF EXISTING PIPES.....	2E-11
REMOVAL OF BRIDGE APPROACHES.....	2E-11
BERM DITCH LOCATIONS.....	2E-11
EXTENSION OF EXISTING PIPES.....	2E-11
SKEW ANGLE OF DRAINAGE STRUCTURE	2E-12

SECTION 2E - 3 - DETAILED PLAN DESIGN

	Page
CURB AND GUTTER (ALSO SEE "MOUNTABLE CURB AND CURB AND GUTTER").....	2E-13
CURB (ALSO SEE "MOUNTABLE CURB AND CURB AND GUTTER").....	2E-14
MEDIANS (ALSO SEE "MOUNTABLE CURB AND CURB AND GUTTER")	2E-14
STAKING FOR CONCRETE ITEMS	2E-16
FENCE	2E-20
TRAFFIC BARRIERS - GUARDRAIL AND CONCRETE BARRIERS	2E-21
SHY LINE	2E-21
CLEAR ZONE.....	2E-21
RUN-ON TERMINALS.....	2E-21
RETAINING WALLS.....	2E-22
SOUND BARRIER WALL DESIGN PROCEDURES	2E-22
STEPS AND HANDRAILS.....	2E-23
SIDEWALK.....	2E-23
SIGN ISLANDS	2E-23
RAILWAYS: ADJACENT HIGHWAY DESIGN CONSIDERATIONS	2E-24
BICYCLE FACILITIES.....	2E-26
GREENWAYS	2E-26
UNDERDRAINS	2E-26
DEMOLITION OF PAVEMENT - OBSCURING OLD ROAD	2E-27
TREE WALLS AND TREE WELLS.....	2E-27

	Page
LABELING INCIDENTAL ITEMS.....	2E-27
PEDESTRIAN RAMPS.....	2E-27
MOUNTABLE CURB AND CURB AND GUTTER	2E-27
GRADING CONTOURS	2E-28
CONSTRUCTION OF CATTLE PASSES.....	2E-28

SECTION 2E - 4 - SHOWING BRIDGE LIMITS ON PLANS

	Page
DETERMINING APPROXIMATE LENGTH OF BRIDGE.....	2E-29
DETERMINING APPROXIMATE WIDTH OF BRIDGE	2E-29
DEPICTING ON PLANS	2E-29

SECTION 2 E - 5 - PROPOSED RIGHT OF WAY AND LIMITED ACCESS

	Page
DETERMINING PROPOSED RIGHT OF WAY ENCOMPASSING SLOPE LIMITS	2E-30
DETERMINING PROPOSED RIGHT OF WAY WITH SLOPE EASEMENT	2E-31
DETERMINING SLOPE EASEMENTS.....	2E-31
CONSTRUCTION EASEMENTS.....	2E-32
DETERMINING PERMANENT EASEMENTS	2E-32
UTILITY EASEMENTS	2E-33
LIMITED ACCESS LINES	2E-36
DEPICTING LIMITED ACCESS RIGHT OF WAY	2E-37
SEPARATE RIGHT OF WAY PLANS	2E-37
PROPERTY REQUIRING METES AND BOUNDS DESCRIPTION	2E-37
RIGHT OF WAY DESCRIPTION FURNISHED TO ENVIRONMENTAL DIVISION.....	2E-40
PLAN REVISIONS.....	2E-46

SECTION 2E - 6 - PREPARATION OF SUPPLEMENTAL SHEETS

	Page
TITLE SHEET (ALSO SEE FIGURES 2E - 11, 2E - 12, & 2E - 13).....	2E-47
IDENTIFICATION	2E-47
LAYOUT	2E-48
DESCRIPTION	2E-49
PROJECT LENGTH TABULATION.....	2E-49
FUNCTIONAL CLASSIFICATION - TRAFFIC DATA	2E-51
NOTES	2E-51
PROJECT LOCATION MAP (ALSO SEE FIGURE 2E - 16).....	2E-57
RIGHT OF WAY DATA SHEET (ALSO SEE FIGURE 2E - 17).....	2E-57
TYPICAL SECTION SHEET(S) (ALSO SEE FIGURE 2E - 18).....	2E-62
DESIGN FEATURES NOTE.....	2E-66

SECTION 2E-7- CONSTRUCTION COST ESTIMATE

	Page
ESTIMATING QUANTITIES - PREPARATION OF ESTIMATE.....	2E-67

SECTION 2E-8- CONSTRUCTABILITY QUALITY REVIEW

	Page
CONSTRUCTABILITY QUALITY REVIEW	2E-69

SECTION 2E – 9 - DISTRIBUTION OF FIELD INSPECTION PRINTS

	Page
PROCEDURE AND SCHEDULING.....	2E-70
PLAN ASSEMBLY	2E-70

SECTION 2E – 10 - FIELD INSPECTION

	Page
HOLDING THE FIELD INSPECTION	2E-73
SAFETY ITEMS AND SEQUENCE OF CONSTRUCTION	2E-74
REQUEST FOR SPECIAL DESIGN PLANS	2E-75
REQUEST FOR SOUND BARRIER WALL DESIGNS	2E-76
BRIDGES	2E-76
REQUEST FOR SPECIAL PROVISIONS	2E-76

SECTION 2E - 11 - REQUEST FOR ADDITIONAL SURVEY DATA

	Page
PROCEDURE FOR REQUEST	2E-77

SECTION 2E – 12- DISTRIBUTION OF PRINTS

	Page
PROCEDURE.....	2E-78

SECTION 2E-13 UTILITY FIELD INSPECTION

	Page
UTILITY FIELD INSPECTION	2E-79

LIST OF FIGURES

	Page
FIGURE 2E – 1 PLAN DEVELOPMENT/RESOLUTION OF BORROW/SURPLUS AND UNSUITABLE MATERIAL.....	2E-4
FIGURE 2E-2 TYPICAL METHOD OF PLACING UNSUITABLE MATERIAL.....	2E-5
FIGURE 2E-3 INCORRECT METHOD OF PLACING UNSUITABLE MATERIAL.....	2E-5

	Page
FIGURE 2E-4 TYPICAL METHOD OF SHOWING PLACEMENT OF UNSUITABLE MATERIAL ON PLANS	2E-6
FIGURE 2E-5 ANGLE OF SKEW FOR DRAINAGE STRUCTURES	2E-12
FIGURE 2E-6 TYPICAL STRAIGHT-LINE TAPER LANE	2E-17
FIGURE 2E-7 METHOD OF SHOWING REQUIRED INFORMATION ON ROADWAY PLAN SHEETS FOR RADIAL OFFSETS – TURN LANES – BULLET NOSES	2E-18
FIGURE 2E-8 SAMPLE TABULATION OF DATA.....	2E-19
FIGURE 2E-9 SAMPLE METES AND BOUNDS SHEET.....	2E-39
FIGURE 2E-10 DEPICTING LIMITED ACCESS RIGHT-OF-WAY	2E-41
FIGURE 2E-10 DEPICTING LIMITED ACCESS RIGHT-OF-WAY	2E-42
FIGURE 2E-11 SAMPLE TITLE SHEET (URBAN DESIGN)	2E-43
FIGURE 2E-12 SAMPLE TITLE SHEET (SECONDARD DESIGN)	2E-44
FIGURE 2E-13 SAMPLE TITLE SHEET (PRIMARY)	2E-45
FIGURE 2E-14 CONSTRUCTION TYPE CODE FOR HIGHWAY IMPROVEMENTS LINE ITEM CODES.....	2E-53
FIGURE 2E-15 INDEX SHEET FOR MULTI-PROJECT PLANS.....	2E-56
FIGURE 2E-16 SAMPLE PROJECT LOCATION MAP	2E-59
FIGURE 2E-17 SAMPLE RIGHT-OF-WAY DATA SHEET.....	2E-60
FIGURE 2E-18 SAMPLE TYPICAL SECTION SHEET	2E-61
FIGURE 2E-19 SAMPLE HYDROLOGIC DATA SHEET	2E-64
FIGURE 2E-20 SAMPLE HYDROLOGIC DATA SHEET (NO PLAN PROJECT)....	2E-65

CHAPTER 2E - PHASE III, FIELD INSPECTION

SECTION 2E – 1 - SOIL SURVEY AND PAVEMENT DESIGN

SOIL SURVEY AND PAVEMENT DESIGN RECEIVED

Soil survey and pavement design recommendations are not always received prior to field inspection. Should they be received just prior to the field inspection, every effort should be made to have the recommendations included in plans prior to printing. In some cases, the field inspection will be held based on the preliminary pavement design without the benefit of the soil survey. (See Section 2E-6-TYPICAL SECTION SHEET)

RESOLUTION OF BORROW / SURPLUS AND UNSUITABLE MATERIAL

VDOT's Road and Bridge Specifications requires that the contractor deposit unsuitable and surplus material off the project if the plans do not require that the material be placed within the right-of-way.

The procedural flow chart (See Figure 2E-1) is self-explanatory in the development of plans to resolve the disposition of materials on either a borrow or surplus project in connection with disposal areas and borrow pits.

The non-environmentally sensitive fill areas within the limits of a project should be reviewed for possible locations to dispose of unsuitable material. Do not place disposable material in areas where retaining walls or sound walls will be used. Check all proposed drainage items pertinent to this procedure. In some instances, the Materials Division will recommend that disposable material be placed in the bottom of fills; however, the available areas may or may not satisfy the volume of material to be disposed. The designer must therefore look to other methods of placing this material along with the placement of surplus root mat material that may be disposed of by using it to cover fill slopes. Placement of unsuitable material in fills is limited to an elevation 2 m (6') below the top of the proposed subgrade at the side slope. This will prevent entrapment of moisture in the embankment below the pavement structure (See Figure 2E-2). Unsuitable material is defined as highly plastic clay soil ($PI \geq 35$). Wet material (moisture content > 30 per cent above optimum moisture content), muck, peat, and other deleterious material. Organic material (stumps, tree trunks, limbs, roots, leaves, grass cuttings) shall not be disposed of on slopes. A plan for disposal of all unsuitable material shall be submitted by the Contractor to the Engineer at least 7 days prior to disposal for review. Inorganic material such as brick, cinder block, broken concrete,

(without exposed reinforcing steel) asphaltic concrete, rock or other such material may be disposed of in fills.

Consideration should be given to flattening slopes using borrow on top of unsuitable material instead of installing guardrail (Exception: When major slopes of 3:1 and flatter will provide an acceptable condition for a vehicle leaving the roadway. Provide recoverable 6:1 slope when possible (See [Appendix A](#) for guidelines). Gore areas of ramps and median areas of divided facilities (unless they are used for stormwater management) are prime areas for placing disposable material. (See Figures 2E-2 and 2E-4)

It is also likely that in some cases, such as the placement of unsuitable material in the bottom of fills, that borrow can be reduced, thereby reducing the cost of a project. Another case would be in the area between the normal and the proposed flatter safety slope.

In no case should a vertical line be used to separate the good material from the unsuitable material (See Figure 2E-2). Roadway compaction must be obtained over the width of the normal roadway section from toe to toe of fill.

Unsuitable material placed outside the normal roadway section will not normally require the standard practice for compaction of fills. If concurrence is received from the Materials Engineer to waive density requirements of fill material placement outside the normal roadway section, then the following note is to be shown with the typical sections denoting the method of placing unsuitable material, giving location, station to station, etc.

Note: "The density requirement for embankment will be waived in the placement of unsuitable material."
--

When the shoulders are being constructed of commercial material, this material should be extended to intersect the flatter slope (See Figure 2E-2).

Figure 2E-4 is a sample plan that has been prepared to denote, by a series of double hatched lines, the designated area for the placement of unsuitable material on slopes of a roadway facility being constructed in fills. Typical sections showing the theoretical methods to be used for the placement of such materials are to be included in the plans, along with the roadway typical sections. The designer is reminded to check all proposed drainage items pertinent to this procedure.

In essence disposal of unsuitable material within the project limits eliminates the need to haul the material to a waste site, which should reflect in the unit price for regular excavation. There could be a savings in right-of-way cost to acquire the site, if one is not available. Borrow excavation is reduced in some cases, depending on the position

the material is placed within the roadway fill section. With flatter slopes, some guardrail may be eliminated, reducing costs and providing a safer facility. The designer should make a careful analysis of where the unsuitable material is being removed and where it is to be placed to determine if a double haul will be required. If a double haul is required, it could make the design uneconomical due to the extra cost in handling and stockpiling. Consequently, once the soil survey is available, the method of disposing of unsuitable material must be reviewed and approved by the District Administrator or his/her designated representative.

When root-mat is disposed of by using it to cover fill slopes, the following note is placed on the plans on the [grading diagram and summary sheet](#):

" _____ m³ (_____ Cu. Yds.) of Root-mat topsoil is to be stockpiled and used for covering fills to a depth of _____ mm (_____ inches). Placement is limited in all situations to an elevation of at least 2 meters (6 feet) below the top of the proposed subgrade at the side slope and at locations where and as directed by the Engineer. All debris which would impede mowing operations is to be removed from the top 3 meters (10 feet) of the fill slope."

The designer is to adjust the depth used in an effort to use up the supply of root-mat. Removal and stockpiling root-mat is paid for as regular excavation and the basis of payment for spreading is to be "Topsoil Class A," by the acre.

The Grading Diagram and Summary, as discussed in [Section 2G-2](#), provides guidelines in arriving at usable cut quantities when using the Grading Diagram method.

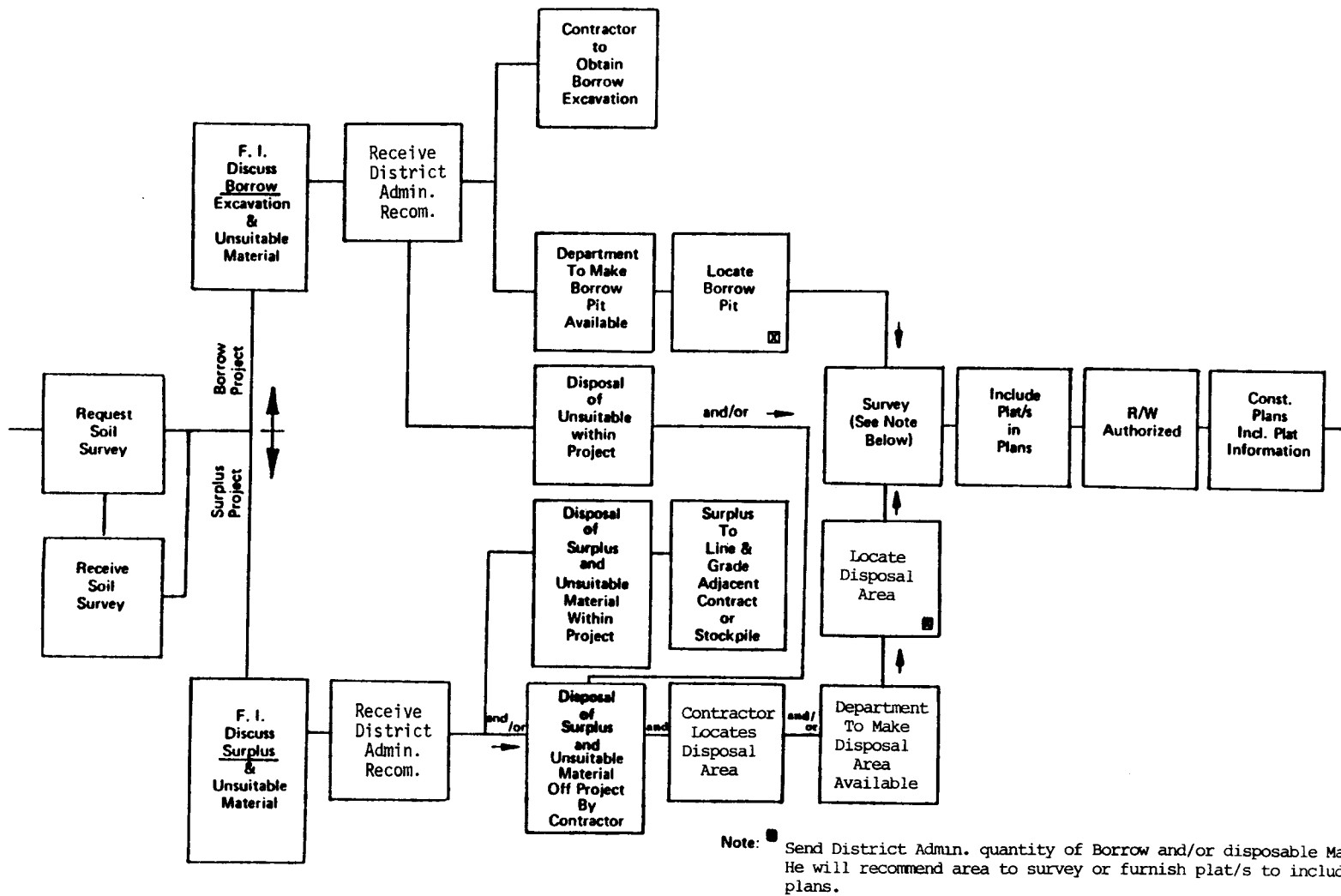

FIGURE 2E – 1 PLAN DEVELOPMENT/RESOLUTION OF BORROW/SURPLUS AND UNSUITABLE MATERIAL

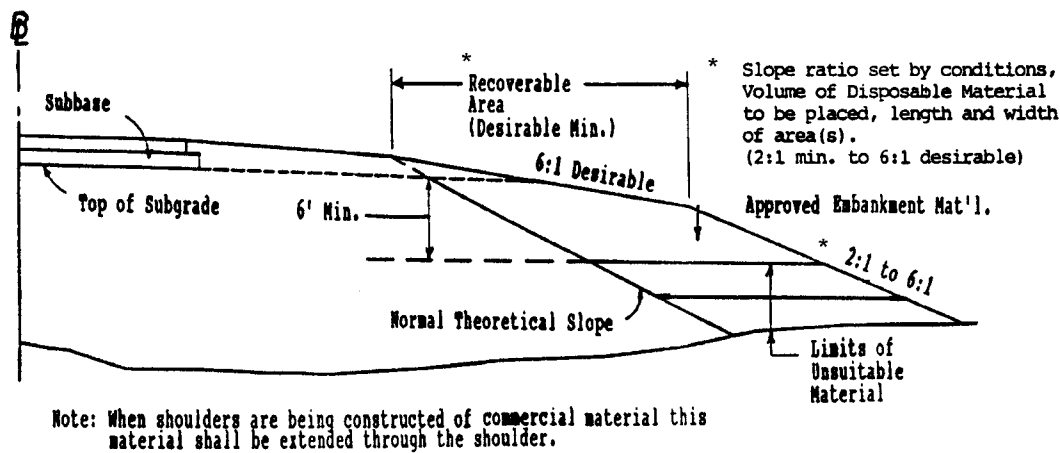
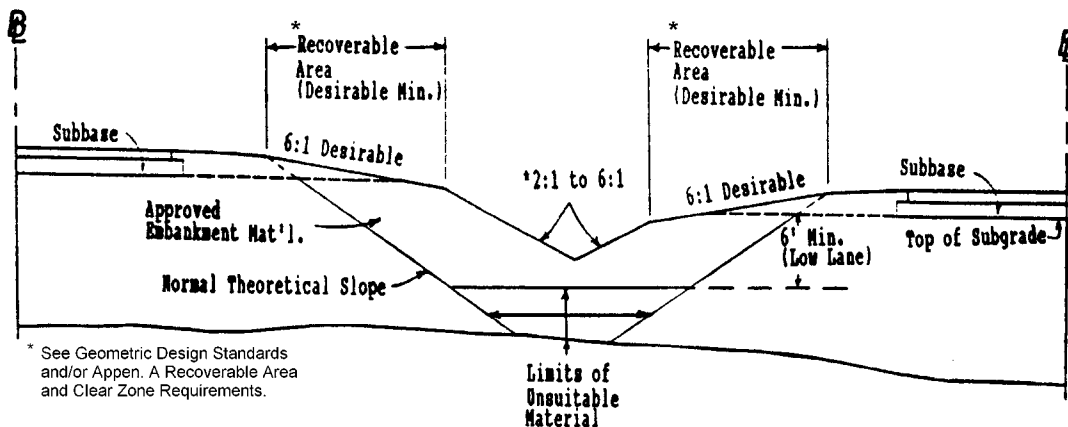

FIGURE 2E-2 TYPICAL METHOD OF PLACING UNSUITABLE MATERIAL

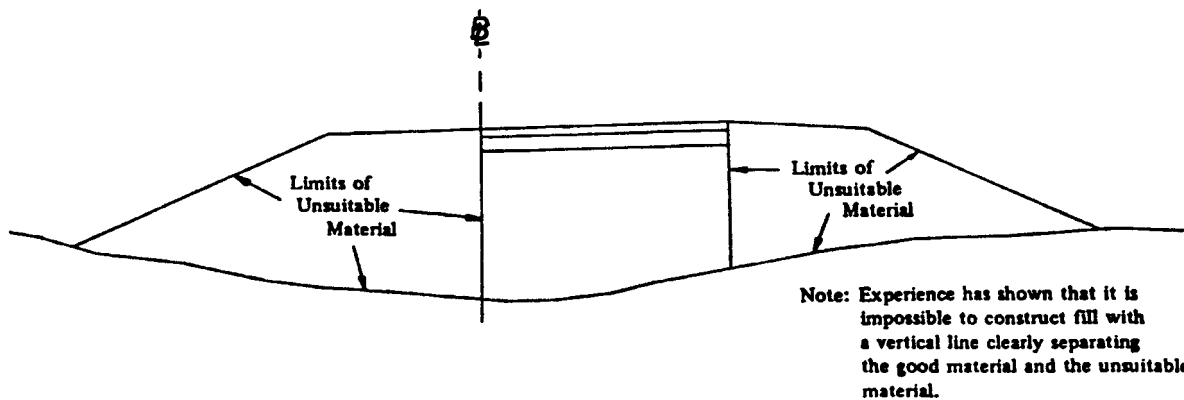

FIGURE 2E-3 INCORRECT METHOD OF PLACING UNSUITABLE MATERIAL

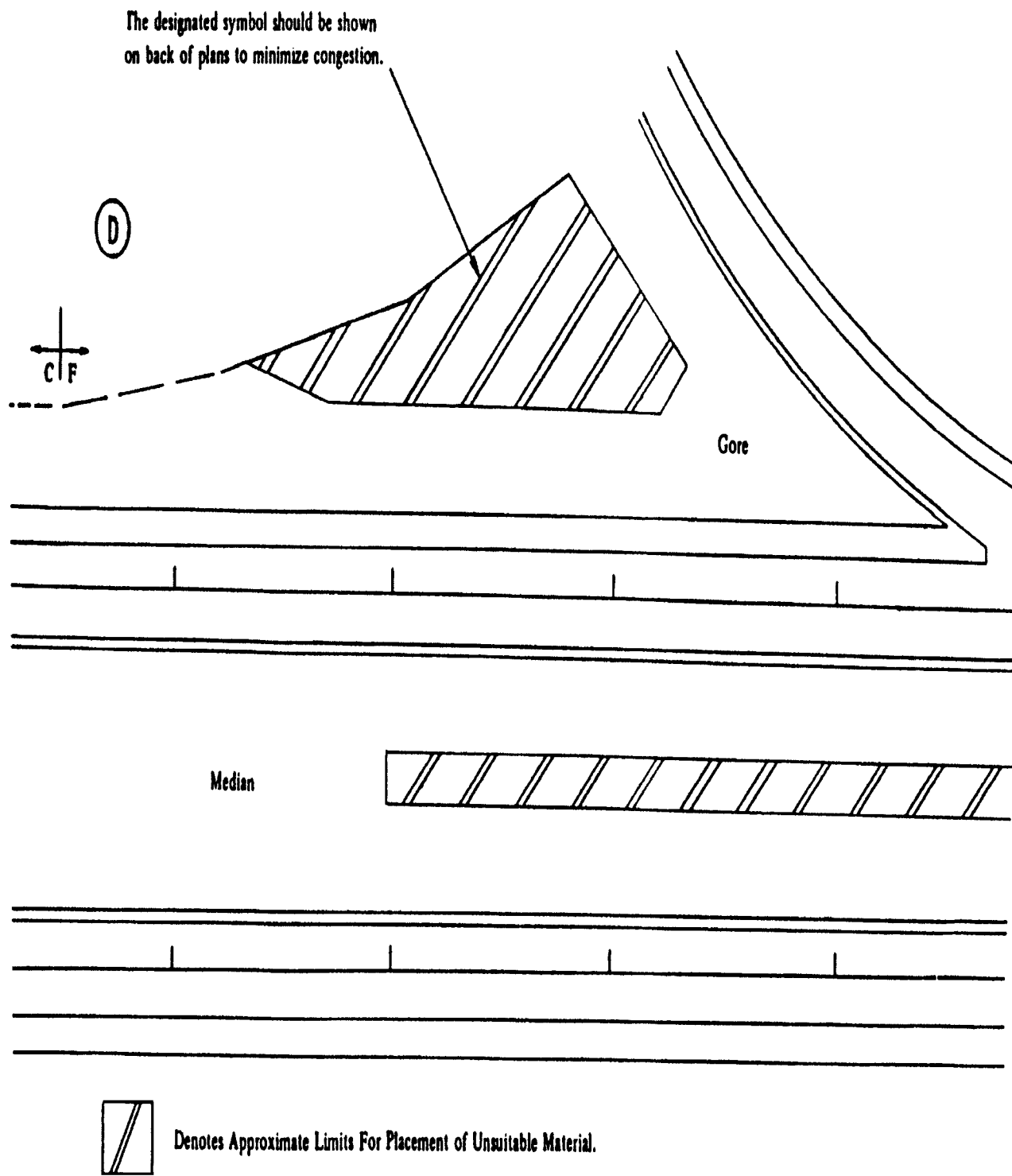

FIGURE 2E-4 TYPICAL METHOD OF SHOWING PLACEMENT OF UNSUITABLE MATERIAL ON PLANS

SECTION 2E – 2 - DETAILED DRAINAGE DESIGN

DESIGNING DRAINAGE

Drainage shall be designed in accordance with criteria established in the Drainage Manual and Instructional and Informational Memoranda.

Highway drainage will be designed by the District Drainage Engineer (with such technical assistance as may be necessary from the Central Office Hydraulic Section) or by the [Hydraulic Section](#) of the Central Office, depending on whether the road plans are being developed in the District or in the Central Office.

At the time the drainage design is initiated, the plans should be reviewed by the Hydraulic Section or the District Drainage Engineer for information as to areas that have been delineated as flood prone, have designated regulatory floodways and/or other constraints that may affect the design.

In developing the plans for field inspection, careful consideration must be given to erosion and sediment control. Required measures, in addition to those covered by construction specifications, that necessitate additional plan details, will be included in the plans and will be considered by the field inspection party on a site-by-site basis.

Guidelines for erosion and sediment control may be found in the VDOT Drainage Manual, the Virginia Soil and Water Conservation Commission's Virginia Erosion and Sediment Control Handbook, IIM LD-11, and IIM LD-195.

DEPICTING DRAINAGE ON PLANS

Proposed drainage items are to be shown on plans to scale, with [construction limits](#) being adjusted accordingly.

Drop inlets are to be drawn to actual scale, using a heavier line weight than the curb and gutter for distinction. Proposed pipes and box culverts are shown by dashed lines (See [Figures 2D-2](#) and [2D-3](#)).

Proposed pipes that are 1050 mm (42") or smaller are to be shaded, while 1200 mm (48") and larger pipes are to be shown using the open method with heavy lines. [Flow arrows](#) are to be shown at each proposed pipe, box culvert, and ditch.

Special Design drawings showing details for erosion and siltation control are available in

the CADD Directory. Frequently, additional special design drawings are required for a project. These sheets are to be inserted in the plans and numbered in the "2" series where applicable.

In cases where complexity will not permit individual labeling, [numbers within ellipses](#) are to be shown for individual structures. The first number within the ellipse will designate the sheet number of the plan sheet that contains the proposed item, and the second number will designate the assigned item number (See IIM LD-223). The corresponding descriptions are to be shown where space will permit. If all descriptions cannot be shown on the plan sheet, a separate sheet should be provided. This separate sheet is to be referenced on the plan sheet. When numbering storm sewer items, the individual numbers should be assigned to items at the ends of pipes such as drop inlets, manholes, endwalls, end sections, etc., with the pipe description labeled number to number. The pipe size should be shown adjacent to the pipe and as close to the flow arrow as possible.

Drainage descriptions should not be shown on profile sheets.

In cases where structure numbers are provided by the Hydraulic Section, these numbers should be shown as submitted. If, for some reason, it is necessary to change these numbers, the Hydraulics Section is to be advised so that computation sheets may be revised accordingly. Changes shall not be made without the knowledge and consent of the drainage designer.

Drainage descriptions are to be consistently worded and in the form shown in [Figures 2D-1](#) and [2D-2](#) and in IIM-LD-223.

Minor structure excavation is to be computed for all box culverts, pipes of 1200 mm (48-inch) diameter or over, and multiple pipe lines with a total span of 1200 mm (48 inches) or over, in accordance with [Road and Bridge Specifications](#), IIM LD-71 and recommendations received from the Materials Division. The minor structure excavation is to be shown in the applicable drainage description. (See [Appendix D-1 "Ratios For Minor Structure Excavation"](#))

NON-STANDARD ROADSIDE DITCHES

Safety, appearance, and economy necessitate that non-standard roadside ditches be eliminated from our plans or be minimized to the greatest extent reasonable for all highway projects.

Where the volume, flow, or other considerations dictate enlarging or deepening the roadside ditch or otherwise deviating from the standards, careful study must be given to the following:

1. Enclosing the drainage, where economically feasible, in order to eliminate the need for the non-standard roadside ditch or channel.
2. Minimizing the size and depth of the proposed non-standard roadside ditch or channel. Careful consideration of the available locations for the ditch (each side of the road and median area) could facilitate this.
3. Flattening the front slope (the slope adjacent to the highway shoulder) of the non-standard roadside ditch or channel. Where right of way is available, or can reasonably be obtained, the front slope of the non-standard roadside ditch or channel should be no steeper than the front slope of the standard roadside ditch for that particular project.
4. Locating necessary non-standard roadside ditches or channels as far from the proposed highway shoulder as the existing or proposed right of way will reasonably allow.

Hazardous and unsightly roadside ditches and channels must be eliminated from the plans wherever possible.

END SECTIONS FOR PIPE CULVERTS

The Standard ES-2 drawing in the Road and Bridge Standards includes a pay line designation that should not be interpreted as a required length of pipe to be attached to the end section. The connector section length may be whatever length the supplier wishes to attach, but the portion of the culvert included within the limits of the "C" dimension will be considered, for payment purposes, to be included with the end section.

Road and Drainage Designers should compute or measure the actual length of culvert required and deduct the "C" dimension length for summaries and pipe description on plans.

Metric Example:

Culvert req'd. = 30.0 m of 900 mm pipe and two end sections

Pipe description and summaries will read thus:

28.0 m - 900 mm Pipe Required

2-St'd. ES-1 or 2 Req'd.

Imperial Example:

Culvert req'd. = 100' of 36" pipe and two end sections

Pipe description and summaries will read thus:

94' - 36" Pipe Required

2-St'd. ES-1 or 2 Req'd.

The supplier may furnish CM sections with no connector section (Alternate connection) or

with whatever length of connector section is convenient. The supplier and contractor will be responsible for determining what combination of culvert pipe length will be required for various lengths of connector sections if any, they wish to furnish. Regardless of the length connector furnished as an attachment to the end section, that portion of the culvert designated "C" will be measured and paid for as end section.

It is especially important that inspectors and other field personnel are aware of these instructions in order that an end section will not be rejected simply because the length of the connector is not the same as that shown on the Standard. This variance is entirely acceptable provided the contractor has adjusted the length of the pipe.

PIPE ENDWALLS WITH LOAD CARRYING GRATE

Pipe endwalls with load carrying grates (St'ds. EW-11 and EW-11A) were designed as a safety feature to prevent an errant vehicle from encountering the hazards of a collision with conventional endwalls. They are intended for use on low height embankments which would be traversable by an out of control vehicle and where guardrail would otherwise not be required. The Standard EW-11A is designed for use at crossover locations where there is no other alternative to placing a pipe culvert under the crossover.

The designer is to carefully study each situation before specifying Standard EW-11 or EW-11A on the plans. Guidelines for the use of these designs are given below:

1. Pipe endwalls with load carrying grates are to be used with traversable slopes (3:1 or flatter) on all classes of highways.
2. Pipe endwalls with load carrying grates are not to be installed where guardrail is required.
3. Pipe endwalls with load carrying grates will not be required on culverts with ends located outside of the required clear zone width. For guidelines, see Section A-2.
4. Crossover locations should be carefully studied to eliminate the need for a pipe culvert under the crossover. In the event there is no other alternative, the Standard EW-11A is to be specified. The approach slopes of the crossover are to be graded 10:1, regardless of the need for a pipe. Cross slopes (i.e., median crossovers, intersecting roads, or driveways) on freeways and other high speed facilities with design or operating speeds of 80 km/h (50 mph) and higher should be desirably sloped at 10:1 or flatter with a 6:1 maximum slope. On low volume or low speed roads, where accident history does not indicate a high number of runoff the road occurrences, slopes steeper than 6:1 may be considered as a cost effective approach.
5. When pipe endwalls with load carrying grates are specified, the designer must be sure that all other hazards in the area are treated in an equally safe manner.

Each project presents the designer with unique circumstances which may require special treatment. If there is any question in the designer's mind, he is to discuss the situation with the appropriate Engineer.

REMOVAL OF EXISTING PIPES

Pipes to be removed, abandoned or cleaned out are to be indicated on the plans forbidding purposes and labeled "To be Removed", "To Be Abandoned", or "To Be Cleaned Out". Any large amount of pipe to be removed, such as an existing storm sewer, should be set up as a separate bid item and summarized in a separate column in the incidental summary. Incidental pipes to be removed should be included in other appropriate pay items such as Regular Excavation (to be specified in the General Notes) or Clearing and Grubbing. (See IIM-LD-110)

REMOVAL OF BRIDGE APPROACHES

In the process of building a new bridged waterway and approaches, it often becomes necessary to remove all or a portion of the existing bridge approach roadway fill throughout the floodplain area. This is necessary for two reasons. First, leaving portions of the old bridge approaches in place may hinder the hydraulic capacity and efficiency of the new facility. In most instances the hydraulic performance of the new facility was predicated on the complete removal of the old one. Second, many of the State and/or Federal Environmental review agencies require that the old bridge and roadway approaches be removed in their entirety and land graded back to its natural contour as a contingency for the issuance of certain environmental permits. The hydraulic engineer responsible for the performance of the hydrologic and hydraulic analysis for the proposed bridged waterway will notify the road designer as to whether or not it will be necessary to remove all or portions of the existing bridge and approaches with the standard form LD-293B memorandum. If it is found necessary to do so, the extent of such removal will be indicated in that memorandum. The details concerning the removal of the old bridge approach fills are more fully described in Chapter 12 of the VDOT DRAINAGE MANUAL.

BERM DITCH LOCATIONS

In all cases, except where severe right-of-way limitations exist, a minimum of 1.5 m (5 feet) and preferably more, is to be provided between the end of the cut slope round-off and the front slope of a berm ditch. Additional right-of-way is to be obtained for construction and maintenance of the berm ditch. (See St'd. PG-7)

EXTENSION OF EXISTING PIPES

Existing pipes are to be extended with the same size and type of pipe that is in place. If end sections are required, then only Standard ES-1 or Standard ES-2 of the same size pipe is to be used. Pipes for extension are to be so noted in the "remarks" column of the

drainage summary. An example of the plan description is as follows:

9 m - 450 mm (30'-18") C.M. Pipe Req'd. for Extension

3 m (9') Cover

1 St'd. ES-2 Req'd.

Projects on which the allowable pipe tabulation provides an option for new pipe installations and end sections are required, the drainage summary shall have a column indicating the optional standard, St'd. ES-1 or St'd. ES-2 Req'd., for the end section. A separate column is required when specifying either a St'd. ES-1 or St'd. ES-2 end section for extensions of pipes of a particular type.

SKEW ANGLE OF DRAINAGE STRUCTURE

The angle of skew shown on the plans for a drainage structure is the angle formed by the centerline of the structure and a line drawn perpendicular to the roadway baseline nearest the ends of the structure.

Where the roadway baseline at opposite ends of the structure are not parallel, an angle of skew for each end of the structure shall be shown on the plans and in the summaries. The angle formed by the structure centerline and a line drawn perpendicular to the mainline baseline shall be shown only on the plans.

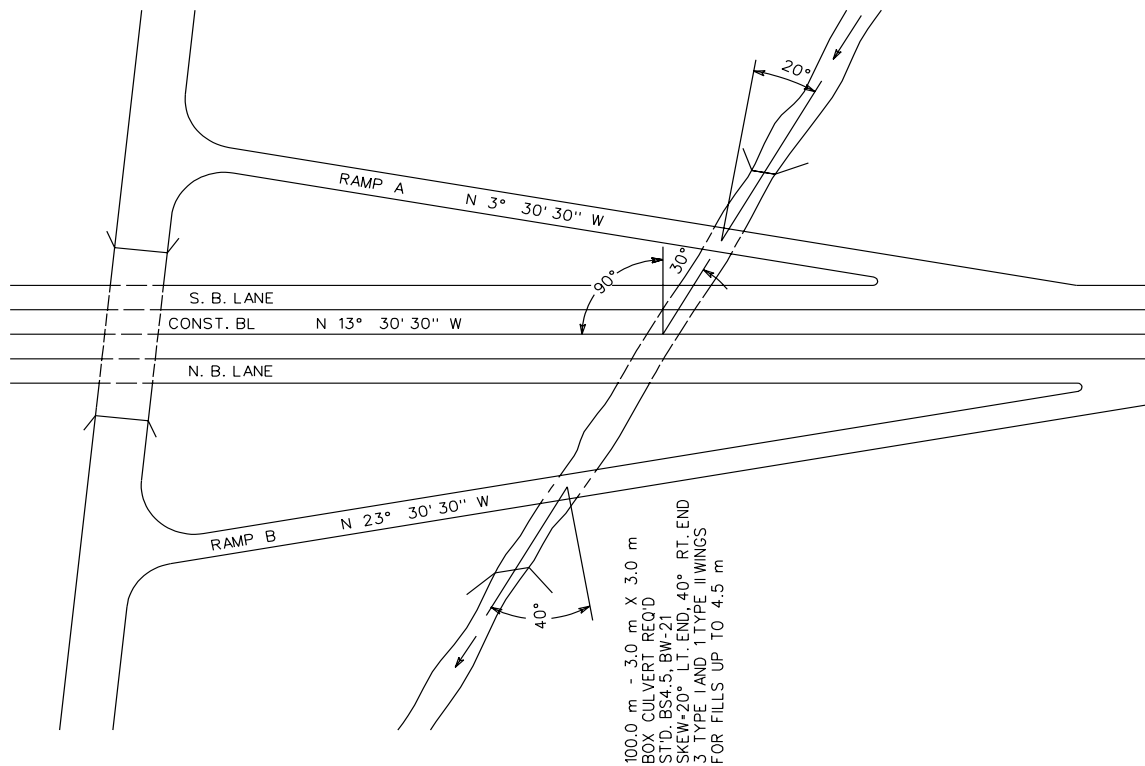

FIGURE 2E-5 ANGLE OF SKEW FOR DRAINAGE STRUCTURES

SECTION 2E - 3 - DETAILED PLAN DESIGN

CURB AND GUTTER (Also see "Mountable Curb and Curb and Gutter")

Curb and gutter on Urban projects will be specified on Form U-9 from the Local Assistance Division. This is the Location and Design Division's authorization to incorporate curb and gutter in the plans. On other projects, curb and gutter will generally be specified only as replacement in kind or as determined at the [Preliminary Plan Review](#).

When using an urban roadway typical section which includes curb and gutter and sidewalk, several design elements should be addressed. Following is a list of the most important items:

1. Will the utility poles be placed back of the sidewalk? While there is a safety advantage to placing poles back of the sidewalk, care must be taken to accommodate the pole crossarm with additional right-of-way and to be sure that local building codes are not violated by placing poles too close to existing buildings.
2. Proposed storm drainage should generally be accommodated under the proposed roadway. The preference of the municipality involved should be considered in this regard.
3. In some instances, retaining walls placed back of the sidewalk can also be in conflict with proposed drainage pipe and/or utilities.
4. The location of traffic signal poles and the need for additional rightt of way to accommodate them is to be considered.
5. The location of Curb Ramps is of prime consideration (See IIM LD-55).
6. The accommodation of rural type mailboxes must be considered on some projects.
7. The location of guardrail and the need for additional right of way to accommodate the guardrail is to be considered. [Fills may need to be widened if guardrail is required.](#)

St'd. CG-6 Curb and Gutter is to be specified unless a municipality specifically requests their own design and the request is approved by the Local Assistance Division. In this case, details are to be shown on the typical sections and basis of payment to be municipality's standard (example: Norfolk St'd. Curb and Gutter).

Curb and gutter is to be plotted to scale in a line weight heavy enough to readily reproduce and stand out over existing items, but not so heavy as to lose details. At street intersections, the face of the radial curb returns should have a minimum 9 mm (30') radius where this can be accomplished with minimum impact on adjacent property. Curb Ramps are to be provided in each quadrant of each intersection or at authorized crosswalks where sidewalk or sidewalk space is provided in conjunction with curb (See IIM LD-55 for additional Curb Ramp instructions).

CURB (Also see "Mountable Curb and Curb and Gutter")

Curb is shown in conformance with the Road and Bridge Standards in the "CG" or "MC" standards for various uses.

Curbs are to be depicted similarly to the previous instructions for curb and gutter.

MEDIANS (Also see "Mountable Curb and Curb and Gutter")

A median is defined as the portion of a divided highway separating the traveled way for traffic in opposing directions. The median width is expressed as the dimension between the through-lane edges and includes the left shoulders, if any. Some of the more common functions of a median are to:

1. Separate opposing traffic
2. Provide a recovery area for out-of-control vehicles
3. Provide a stopping area in case of emergencies
4. Allow space for speed changes/storage of left turning vehicles
5. Provide width for future lanes
6. Minimize headlight glare
7. Offer open green space and areas for landscaping
8. Provide refuge for pedestrians

Medians may be depressed, raised or flush with the pavement surface. The general range of median widths is from a minimum of 1.2 m to 2.4 m (4' to 8') or more. As far as the safety of motor vehicle operation is concerned, the wider the median the better for rural areas, while the opposite is true in urban/suburban areas. Notable exceptions to this are at-grade intersections, where wide medians may cause drivers to become confused over the operational characteristics and the increased time for vehicles to cross the median may lead to inefficient signal operation. Economic, environmental and land use factors very often limit the width of median that can be provided. Therefore, in the selection of a median width, the function(s) the median is to serve must be thoroughly evaluated in balance with the economic, environmental and other impacts.

Depressed medians are preferred on freeways and other high speed facilities where greater separation of opposing traffic is desired. They also allow for more efficient drainage and snow removal. Side slopes should be 6:1; however, a combination of 4:1 and 6:1 may be adequate. The recommended minimum depressed median width is 12.2 m (40') because from a physical and psychological sense, separation from opposing traffic is obtained when medians are 12.2 m (40') or wider. A 12.2 m (40') median also allows for two future lanes with 4.9 m (16') raised median. Again, the wider the median, the better, but with particular attention given to the operational characteristics of at-grade intersections. Also, [clear zone requirements](#) for a particular facility should have significance in the assessment of depressed median width.

Raised medians have application on arterial or urban streets where speeds are in the low to intermediate range and where it is desirable to regulate left turn movements. Raised medians have been found to be most advantageous under the following conditions:

1. High volume of through traffic
2. Little strip development or midblock left turn demand
3. Reasonable indirect access available to serve adjoining properties
4. Undeveloped areas composed of large land parcels
5. Areas where sight distance limitations prevent the use of a two-way left-turn median

The curb of raised medians should be offset 0.3 m (1') from the through lane edge. Raised medians should have a minimum width of 1.2 m (4'). When the raised median's primary purpose is to provide space for speed change/left turn storage, the minimum width should be the required lane width plus 1.2 m (four feet) (i.e. $3.6\text{ m} + 1.2\text{ m} = 4.8\text{ m}$ (12'lane + 4' = 16') total width).

All raised medians wider than 2 m (six feet) are to be seeded, unless they are deemed to create an unnecessary maintenance problem.

Flush medians have application on nearly all functional classifications of roadway. On low to intermediate speed facilities, where there is not a heavy concentration of left turn moves, flush medians can provide for two-way left turn lanes. Two-way left-turn medians are most beneficial under the following conditions:

1. Areas of strip development generating large mid-block left-turn demand
2. Areas with numerous small land parcels and many driveways
3. Sections with less than 12 public streets per 1.6 km (mile)
4. In corridors where operational flexibility is needed for future development and/or traffic needs

The recommended minimum width for this application should be the normal lane width plus 0.6 m (2') i.e., $3.3\text{ m} + 0.6\text{ m} = 3.9\text{ m}$ (11' lane + 2' = 13') total width). When used on higher

speed facilities, such as freeways, a median barrier is nearly always required (see AASHTO's Roadside Design Guide for selection and use of median barriers). The minimum median width for this usage is 3 m (10') i.e., 2 – 1.2 m shoulders plus 0.6 barrier (2-4' shoulders plus 2' barrier), when used with a four lane facility. When a flush median with median barrier is used on a six lane facility, the minimum median width is to be 6.6 m (22'). If truck DHV exceeds 250, then a median width of 7.8 m (26') is desirable. Additional clearance may be required to provide the minimum stopping sight distance along the median lane on relatively short radius curves, when a median barrier is used.

Left turn lanes for all median widths are to be designed using controls shown in [Appendix C, Section C-1](#).

Raised medians or median barriers are to be shown on plans in accordance with VDOT's Road and Bridge Standards and as shown on the approved preliminary design.

STAKING FOR CONCRETE ITEMS

Formed concrete items, such as curb and gutter, curb, median openings, straight line tapers, turn lanes, and channelization require that sufficient station pluses, offset distances, and radii be shown to the face of curb to insure that the project is constructed as proposed and to assist the survey party in staking out the project. This information is usually computed by the designer in order to properly show the design on the plans; therefore, the desired information is readily available and should be included in plans. Be sure that sufficient offsets, pluses, and radii are shown to insure that the staking party can set stakes without field computations.

To more clearly show the required information on the plans and to reduce plan clutter, minimal data is to be shown on the plans with the remaining data shown in tabulation form on a series 2 plan sheet. Figures 2E-6, 2E-7 & 2E-8 denote a typical straight-line taper detail, the method of showing the required information on the plan sheet, and the minimum data that is to be included in the tabulation of data for reverse curve turn lanes and radial offsets.

When reverse curve transition are dictated by local policy, offsets to the reverse curves at maximum 7.5 m (25') intervals along the transition radii of the turn lane are to be provided, in addition to the reverse curve lengths, radii, and begin and end stations with offsets. The radii for these reverse curves should be set using radius lengths such as 60 m (200') (most commonly used), 45 m (150'), or 30 m (100') to provide consistent radii intervals for the contractor. The length of transition for these three radii with a 3.6 m (12') offset only varies from 29 m (97')± to 25 m (84') to 20 m (68'). Therefore, other odd radii may only cause problems in forming concrete.

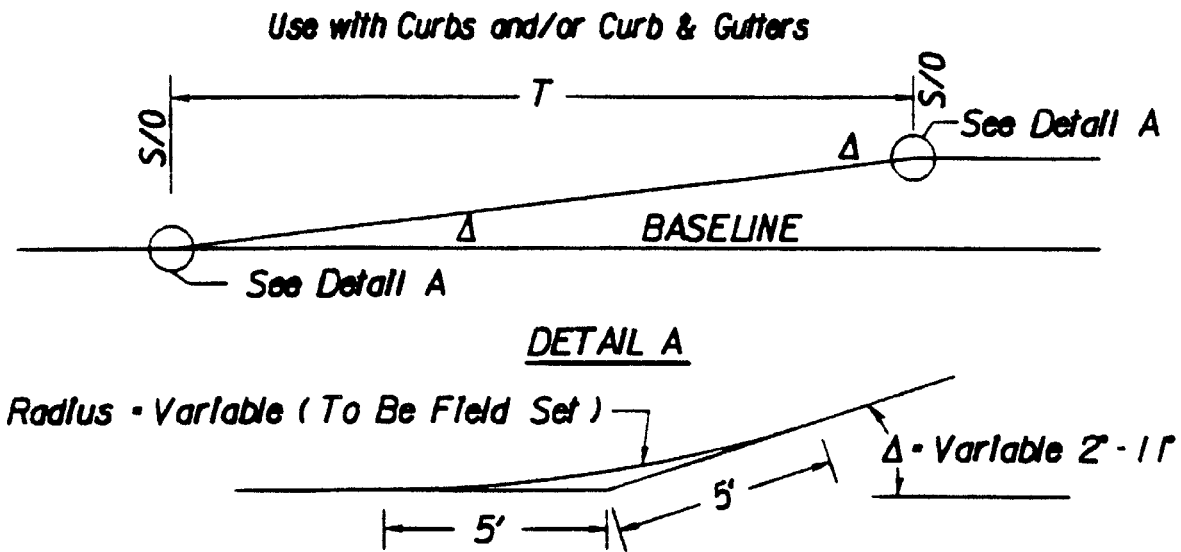

T - See plans for Length of T.

S/O - See plans for Stations and Offsets.

FIGURE 2E-6 TYPICAL STRAIGHT-LINE TAPER LANE

See Figures A-3-1 and A-3-2 for length of taper requirements.

The following note is to be included on the General Notes Sheet, under incidentals, when straight-line taper lanes are used in curb and/or curb and gutter sections.

I-17 For method of constructing straight-line taper lanes in curb and/or curb and gutter sections, see typical details on sheet__.

The Typical Straight-Line Taper Lane detail is to be shown on a number 2 series Typical Section, Detail or Summary sheet when required.

When used for right turn lanes on Urban projects with parallel R/W behind the C & G or sidewalk, the R/W shall be clearly labeled to assure that the desired R/W is obtained.

For method of showing required information on roadway plan sheets, see Figure 2E-8.

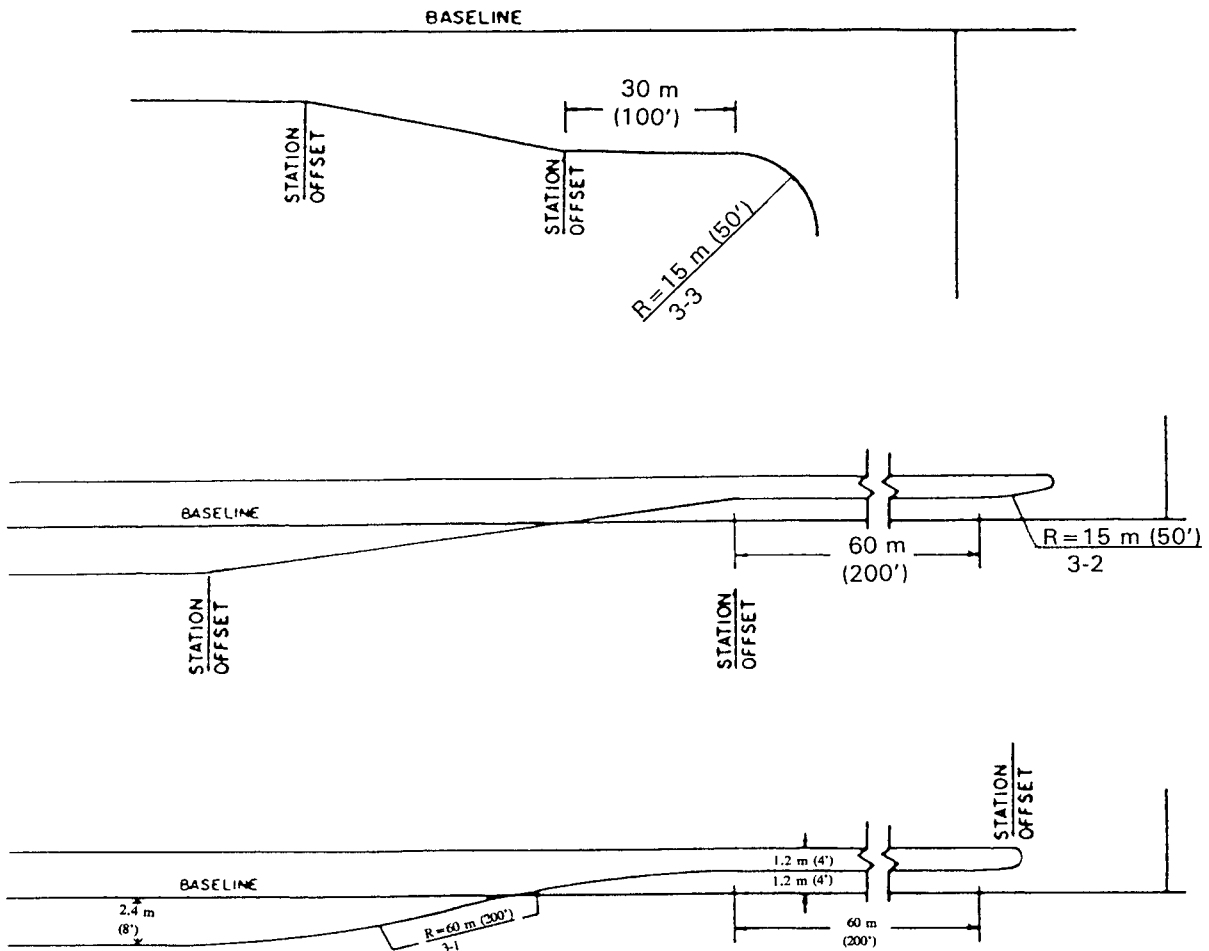

REQUIRED INFORMATION

- Radial Offset....Radius and Reference No.
- Turn Lanes.....Radii, Reference No. and Full Turn Lane Length
- Taper Lanes.....Begin and End Stations and Offsets
- Bullet Noses.....Main Radius and Reference Number

FIGURE 2E-7

**METHOD OF SHOWING REQUIRED INFORMATION ON ROADWAY PLAN SHEETS
FOR RADIAL OFFSETS – TURN LANES – BULLET NOSES**

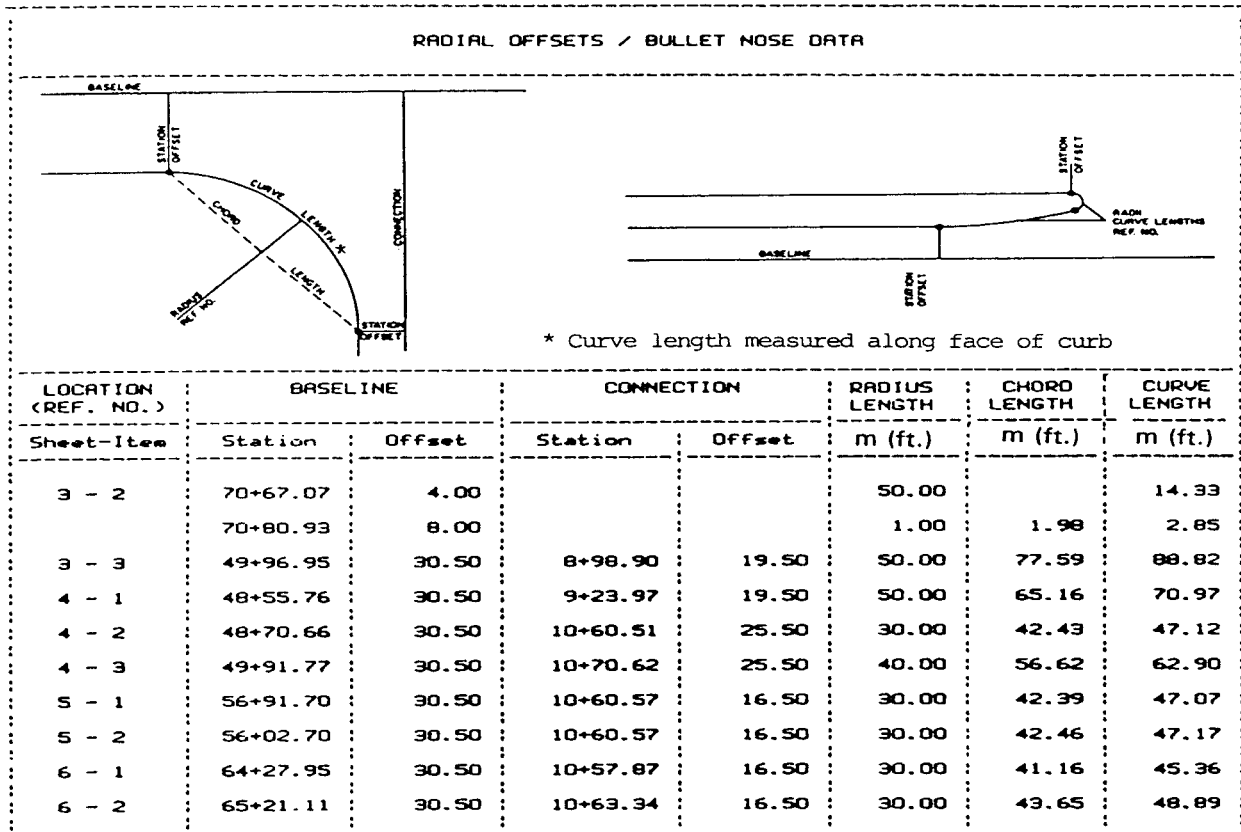
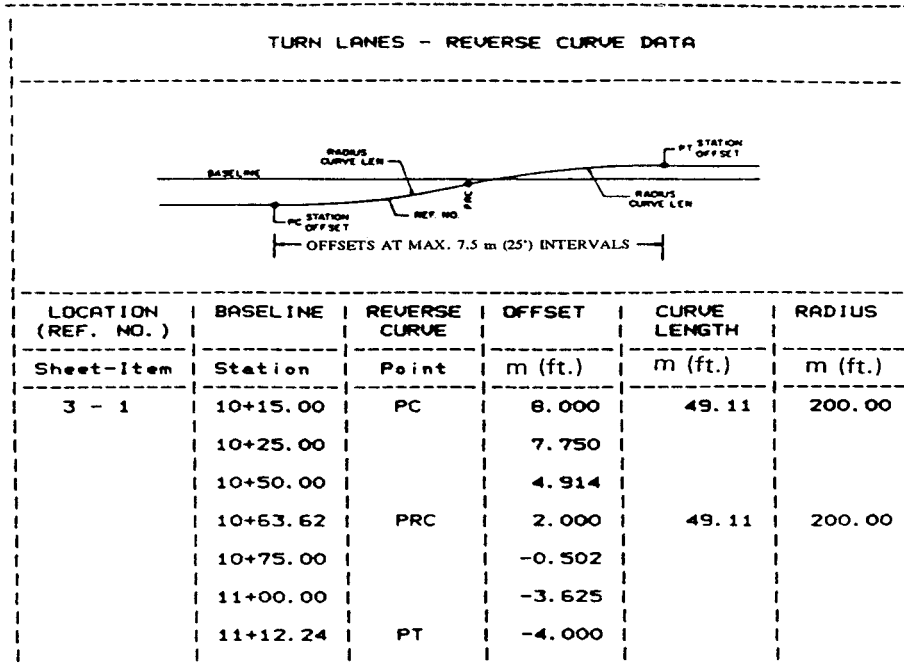

FIGURE 2E-8 SAMPLE TABULATION OF DATA

FENCE

Proposed fence is to be shown on previously determined fenced limited access projects as submitted on the approved preliminary design.

Fenced proposed right of way and limited access lines are denoted by showing "X"s along a solid line. Normally, chain link fence is used within municipalities or other urbanized areas and farm fence is used in rural areas. The type of fencing to be used should always be discussed at the project Field Inspection to assure compliance with local ordinances. Hazardous conditions (barbed wire) should not be created in areas where there will be pedestrians.

Plans are to specify Standard FE-W1 for farm fence, except where specifically recommended otherwise (spacing of vertical strands) as a result of field inspection.

Existing fence replacement is normally covered in right of way agreements and is not a contract item except in rare instances. Proposed fence or fenced limited access lines, where they deviate from proposed right of way lines, are denoted by a dashed line with "X"s between dashes, in a somewhat heavier line than existing fence.

All limited access roadways will be fenced, except where natural terrain prohibits access. Each project shall be studied individually to determine if the fence can be eliminated in locations where deep cuts, high fills, rivers, streams, or other natural means prohibit access. Areas where sound barriers are proposed near the right of way line should be examined to determine the possibility of eliminating fencing beyond the sound barrier at the normal fence line. Otherwise, permanent easements may be required for maintenance.

The maintenance requirements of the sound barrier should be thoroughly discussed at the field inspection to determine if the fence can be eliminated.

When it is recommended at the preliminary plan review not to fence the limited access line, each location is to be thoroughly discussed at the field inspection. Recommendations of these locations shall be included in the Field Inspection Report from the District Administrator and approved by the State Location and Design Engineer.

The above policy is in accordance with An Informational Guide on Fencing Controlled Access Highways - AASHTO 1990.

Fencing of Stormwater basins may occasionally be needed and should be used when:

- 1 - Basin's ponded depth is greater than 1m (3') and/or has side slopes two or more side slopes steeper than 3:1; or

- 2 - Basin is in close proximity to schools, playgrounds or similar areas where children may be expected to frequent; or
- 3 - Recommended by the Field Inspection Report, the Resident Engineer or the city/county (where city/county will take over maintenance responsibility.)

Metal fencing adjacent to an airport sometimes interferes with airport traffic control radar by causing erroneous display on the radar screen. In order to avoid this potentially dangerous situation, when a highway project is adjacent to an airport and has proposed fencing, the designer shall contact the Aircraft Operations Section, which will check with the Federal Aviation Administration to ascertain if metallic fencing will be a problem. Should the FAA determine that the metallic fencing will be a problem, then a nonmetallic design will be used.

Unless circumstances dictate otherwise, plus and distance references for fence breaks will only be required on plans where the fence deviates from the proposed right of way line.

TRAFFIC BARRIERS - GUARDRAIL AND CONCRETE BARRIERS

Traffic barriers are to be provided in accordance with the applicable "GR" or "MB" Standards and Appendix A (Section A-3 Traffic Barrier Installation Criteria).

SHY LINE

Shy line offset is defined as a distance beyond which a roadway object will not be perceived as a threat by a driver. In other words, a driver will not react to an object beyond the shy line offset. If possible, the roadside barrier should be placed [beyond the shy line offset](#). See [Appendix A \(Section A-2 Clear Zone Guidelines\)](#).

CLEAR ZONE

Clear zone is defined as the roadside border area, starting at the edge of the through traveled way (edge of pavement), available for safe use by errant vehicles. Previously, 9 m (30 feet) was considered to be standard clear zone, but current guidelines in [Appendix A](#) and AASHTO's [Roadside Design Guide](#) give values greater or less than 9 m (30 feet), depending on the roadside slopes, operating speed, and traffic volumes.

RUN-ON TERMINALS

[Guardrail terminals](#) are to be provided for all installations, regardless of Functional Classification. The termini of guardrail must be designed and located so there are no exposed rail element ends on which a vehicle could be impaled. With [Std. GR-2](#), the

preferred treatment is to bury the end of the guardrail, using the St'd. GR-6 end treatment, into a cut slope even if the guardrail must be extended a short distance to accomplish this. If the use of St'd. GR-6 treatment is not practical, the St'd. GR-7 or GR-9 is to be used. (See Section A-3 for further instructions).

For [concrete barriers](#) the run-on terminals are to be buried into a cut slope where feasible. When it is impractical to bury the terminal, an approved impact attenuator or a section of guardrail with an approved transition and guardrail terminal is to be used. When operating speeds are below 65 km/h (40 MPH), a turned down section of concrete barrier may be used. It will be necessary to review the location with the [Standards/Special Design Section](#) and, if approved, they will furnish design details.

Proposed guardrail is depicted on the plans similarly to existing guardrail, except that circles are to be shaded and lines are solid and somewhat heavier. Proposed concrete barrier is depicted by a series of parallel lines. See the CADD Manual and the cel library for existing & proposed guardrail cells.

RETAINING WALLS

Retaining walls are to be shown where specified on the approved preliminary plans. Refinement of alignment and grades may, however, necessitate some adjustment in wall locations. Handrail or fencing along the top of walls is to be thoroughly discussed at field inspection for safety considerations.

Where right of way damages may justify the use of retaining walls, the walls are to be shown on prints and presented at the field inspection along with an estimated construction cost. For comparison purposes, a projected right of way line (without the retaining wall) is to also be shown on field inspection prints.

Alternate retaining wall designs, such as cantilever, reinforced earth, etc., are to be considered and discussed with the [Standards/Special Design Section](#) for possible use in lieu of standard designs (especially if wall height exceeds 3 m (10 feet).)

Replacement of decorative or other walls, differing from standard walls, is to be thoroughly discussed at field inspection and, if a special design is necessary, a request is to be forwarded to the Engineering Services Section for design.

SOUND BARRIER WALL DESIGN PROCEDURES

The necessity for sound barrier walls is determined by the Environmental Division. If the wall is deemed necessary, the Environmental Division will contact the Road Designer concerning requirements for the sound wall design. Environmental Division will determine the location and profile elevation of the sound wall and the Road Designer will include the information in the plan assembly.

The contractor is responsible for the design and construction of the sound wall based on the Special Provision and applicable industry guidelines (such as AASHTO *Guide Specifications for Structural Design of Sound Barriers*). These Special Provisions specify the design and construction requirements as part of the road project specifications.

Special Provisions for the sound barrier wall designed by VDOT engineers are prepared by the Scheduling and Contract Division.

For sound barrier walls designed by consultants, Consultant Services Section shall advise the consultants to contact Engineering Services Section for input and direction prior to initiating the development of special provisions. When Engineering Services Section is made aware of a need for special provisions, it will coordinate with the Scheduling and Contract Division and provide Consultant Services Sections a suggested draft of the provisions.

STEPS AND HANDRAILS

Steps and handrails are to be provided where necessary, in accordance with St'd. S-1 or S-2 of VDOT's Road and Bridge Standards.

If decorative, wooden, etc., steps are desired for replacement, they are to be designed by the Engineering Services Section.

SIDEWALK

Sidewalk is to be provided as specified on Form U-9, for replacement in kind, or as shown on the approved preliminary plans.

Proposed sidewalk is depicted with solid lines. For CADD plans, however, proper labeling and line weights will depict. Please review IIM55.

SIGN ISLANDS

Standard Sign Islands are not to be shown on plans prior to field inspection. They will be shown on completed plans only where recommended by the District Traffic Engineer and in accordance with the standard. Sign islands for Secondary projects are to be shown only where recommended by the Resident Engineer.

RAILWAYS: ADJACENT HIGHWAY DESIGN CONSIDERATIONS

Design of Roadways in the Vicinity of Railways

The design of roadways in the vicinity of railways deserves special attention. Avoid designs where traffic signals, road intersections, road grades, and etc. could trap vehicles on the tracks. Design alternatives must be considered which avoid a highway-rail crossing relatively close to an adjacent highway, running parallel to the railway track. Inadequate stacking or storage of stopped vehicles, at an adjacent road intersection, may trap vehicles on the tracks. This topic should be discussed with the Traffic Engineer, who should communicate and coordinate with the railway authority for an acceptable design. They may consider an electrical circuit between the grade crossing warning system and the highway traffic signals which allows the normal sequence of highway signals to be preempted to avoid trapping vehicles on the tracks. The Federal Highway Administration Manual on Uniform Traffic Control Devices addresses the topic of traffic signals at or near grade crossings. Also, avoid highway-rail crossing at which there is an abrupt change in the level of the road's surface as it crosses the tracks.

Highway Construction Adjacent To Railway Tracks

Design details are to be included in the project plans when construction adjacent to a railway track requires temporary sheeting or a bulkhead to protect the tracks. IIM-LD-229 for the minimum railway roadbed section that must be retained (not undercut) for construction adjacent to the track and also denotes the limits where sheeting is required when excavation is involved. Actual requirements may vary slightly and the railway will determine specific submittal requirements.

The applicable typical section, plan, profile and cross section sheets and foundation information (i.e. borings, roadway soundings or consolidation information) for structures such as standard retaining walls, box culverts, etc., are to be furnished to the in the design of the temporary sheeting or bulkheads. The final design details for these structures will be included in the road plans. Bridge or other structure plans, under the supervision of the Structure and Bridge Division, will include the temporary sheeting or bulkhead design, when necessary, along with their other design details.

When required, three (3) copies of the detail drawing along with calculations covering the proposed design are to be furnished to the Department of Rail and Public Transportation for their use in obtaining Railway Company approval.

Criteria For Temporary Sheeting And Bulkheads To Protect Railway Track During Adjacent Highway Construction

1. The live load surcharge from track adjacent to sheeting and bulkheads shall be taken into account in the sheeting and bulkhead design. The recommended live load for each track is the Cooper E 80 load.
2. Allowable stresses contained in the American Railway Engineering Association "Manual for Railway Engineering"* (Chapters 7, 8 and 15) shall be used.
3. A construction procedure for temporary sheeting or bulkhead construction shall be included on the drawing. Show step by step sequence.
4. Safety railings shall be installed when temporary sheeting or bulkheads are within 4.6 meters (15 feet) of track.
5. A safety factor of 2 shall be used in the temporary sheeting or bulkhead design.

*Available from the Department of Rail and Public Transportation.

Drawings and Calculations Needed For Approval

1. Three (3) copies of detailed drawings showing the following:
 - a. Timber, steel, bolt and weld sizes and details.
 - b. Dimensions showing distances from centerline track to temporary sheeting or bulkheads and between supporting elements.
 - c. Section showing temporary sheeting or bulkhead heights and track elevation.
 - d. Note: Contractor to provide handrail protection (H = 0.9 meter (3'-0") minimum for excavation adjacent to track or leave sheeting 0.9 meters (3'-0") minimum above ground line adjacent to excavation.
 - e. Drawings must be to scale.
2. Calculations covering temporary sheeting or bulkhead design.

Clear Zone Requirements

A minimum of 6.7 meters (22') of [clear zone](#) is required adjacent to railway tracks.

BICYCLE FACILITIES

Bicycle Facilities are to be provided as specified, for replacement in kind, or as shown on the approved preliminary plans. Proposed Bicycle Facilities and crossing of bicycle facilities are to be depicted with light, solid lines and proper labeling.

GREENWAYS

All official Greenways (as defined in Chapter 1B, Section 1B-2) that cross the proposed highway right-of-way are to be depicted with light and solid lines.

UNDERDRAINS

Underdrains are installed for a number of purposes, most of which may be included in the following classifications:

1. Control of seepage in cuts or side hill location.
2. Lowering of ground-water table.
3. Base, subbase and subgrade drainage.

(See IIM LD- 130 for more information on underdrains).

St'd. UD-1 Underdrains are to be shown on the plans at locations prescribed in the soil investigation report from the Materials Division. The underdrains are to be depicted similar to pipe culverts and located generally parallel to the roadway as shown in VDOT's Road and Bridge Standards. St'd. UD-4 or UD-5 pavement edgedrains will be provided, where recommended, to provide drainage for pavement subbase, in addition to St'd. UD-1's as recommended at F.I.

St'd. UD-2 underdrains are to be located under raised grass medians at locations discussed at field inspection and recommended by the Materials Division.

St'd. EW-12 is to be used at the outlet ends of all St'd. CD's and UD's which do not tie to other drainage structures.

St'd. UD-2 underdrains are to be depicted on the plans as described for St'd. UD-1 underdrains. Care must be taken to insure proper treatment of drainage at the outlet end of the system. St'd. CD-1 underdrains are to be located where the proposed grade passes from a cut to a fill condition. They are to be placed only in cuts of appreciable length and in downgrade situations as shown in VDOT's Road and Bridge Standards.

They are to be depicted as described for St'd. U-1 underdrains. St'd. CD-2 underdrains are to be placed in sag fill situations and at bridge approach slabs as indicated in VDOT's Road and Bridge Standards. They are depicted as described for Standard UD-1 underdrains.

St'd. UD-3 Sidewalk Underdrains are to be provided as determined at the project Field Inspection.

Underdrains are to be provided in ramp gore areas to collect subsurface water on down grade situations as described in IIM LD 130.

DEMOLITION OF PAVEMENT - OBSCURING OLD ROAD

Demolition of pavement and obscuring old road are to be computed and depicted on plans as outlined in IIM LD 47. These items are to be shown on the plans after right of way has been plotted.

TREE WALLS AND TREE WELLS

The designer is required to review the proposed location and design of all tree walls and tree wells with the Environmental Division prior to inclusion in the plan assembly.

LABELING INCIDENTAL ITEMS

All incidental items, if not denoted individually, may be denoted by numbers within equilateral triangles [having 10 mm \(3/8"\) sides with a description of the particular item shown in a conspicuous location](#) on each plan sheet. Labeling should be consistent between plan sheets and typical sections.

PEDESTRIAN RAMPS

See Instructional and Informational Memoranda IIM LD- 55.

MOUNTABLE CURB AND CURB AND GUTTER

Mountable curb and mountable combination curb and gutter, St'd. CG-3 and St'd. CG-7, will be used on rural highways with a design speed greater than 65 km/h (40 MPH) and in developed Urban and Suburban areas with a design speed greater than 70 km/h (45 MPH). The use of barrier curb and combination curb and gutter, St'd. CG-2 and St'd. CG-6, will be limited to Rural projects with a design speed of 65 km/h (40 MPH) or less and 70 km/h (45 MPH) or less in developed Urban and Suburban areas. When St'd. CG-3 and/or St'd. CG-7 is specified on the plans, the regular designation for entrance gutters, street Connections, median strips, etc., will be used.

GRADING CONTOURS

The need to provide proposed grading contours at interchange locations should be discussed at field inspection. Particular attention should be given to contouring gore areas and areas where drainage structures will be constructed to insure that the final design can be safely traversed by a vehicle within the established [clear zone](#) for a particular project. Gore areas at entrance ramps in cut situations should also be discussed to assure that adequate [horizontal sight distance](#) will be provided. Unless otherwise directed, as a result of field inspection or written recommendations, proposed grading contours are to be included in the plan assembly using 1 meter (2-foot) intervals. The proposed contours are to cover either all or portions of the interchange area where the design can more clearly be defined in order that the plans clearly reflect the limits of fill or cut construction. This will also be of benefit in the placement of guardrail, in the interest of safety and general final appearance of the proposed design.

CONSTRUCTION OF CATTLE PASSES

Cattle passes will not be built on two-lane highways with right of way of 33 m (110 feet) or less; however, existing structures may be widened. If the property owner desires a cattle pass and pays the difference between such a structure and the structure that is required for drainage, then a cattle pass may be constructed. Where the right of way width is over 33 m (110 feet) and the plans for the present or future construction provide for a four-lane divided highway, cattle passes may be constructed under certain conditions. If the land on each side of the highway is under the same ownership, at least forty (40) head of horses or cattle are to be passed from one side of the right of way to the other daily, and its construction is recommended by the Right of Way Engineer and approved as to location by the Transportation Engineer, a cattle pass may be constructed upon approval by the Chief Engineer.

Previous studies and investigations have determined that a St'd. 1.5 m x 2.0 m (5' x 7') Box Culvert or an equivalent metal pipe is to be provided for access when the need has been established and so documented. In the location and design of the structure, especially on a four lane divided facility where the barrel length would be long, special attention is required to provide day-lighting when the barrel length approaches or exceeds 60 m (200 feet). Sufficient light must be available or the structure will not serve its intended purpose. Erosion control, if required, should have a smooth surface. Sufficient light and a smooth surface are both necessary for horses and cattle to enter a structure. The plan description shall indicate the purpose of the structure. Example: St'd. 1.5 m x 2.0 m (5' x 7') Box Culvert Req'd. For Cattle Pass.

SECTION 2E - 4 - SHOWING BRIDGE LIMITS ON PLANS

DETERMINING APPROXIMATE LENGTH OF BRIDGE

The approximate length of a proposed bridge is determined by projecting the spill slope upward from existing stream banks, proposed channel slopes, or existing or proposed roadway ditches to the finished grade line of the higher roadway.

These limits must be adjusted when bridge plans are completed.

DETERMINING APPROXIMATE WIDTH OF BRIDGE

The approximate width of proposed bridges is determined by applying the appropriate [geometric design standard](#), with additional sidewalk spaces where applicable.

DEPICTING ON PLANS

Outer limits of bridges, including wingwalls, are to be plotted with heavy solid lines. Beginning and ending of bridge projects are to be flagged.

SECTION 2 E - 5 - PROPOSED RIGHT OF WAY AND LIMITED ACCESS

DETERMINING PROPOSED RIGHT OF WAY ENCOMPASSING SLOPE LIMITS

All existing right of way acquired in fee will be shown on plans as established by the survey information or other data. The plans will not designate prescriptive or statutory right of way as existing right of way.

The width of [proposed right of way](#) shall be sufficient to accommodate the roadway cross-section elements and requisite appurtenances necessary for an adequate facility in the design year and for known future improvements.

Minimum right of way widths are to be set in accordance with the "CS" standards in VDOT's Road and Bridge Standards.

Right of way breaks are to be set at reasonable longitudinal distances so as not to obtain excessive right of way. Breaks are to be spaced at sufficient intervals so that the right of way line will not be unreasonably irregular and are to be located in accordance with the Criteria for Placement of Right of way Monuments covered in [Appendix C, Section C-3-RIGHT OF WAY](#).

There are instances when it is desirable to acquire an entire parcel. This occurs when only a portion of the parcel is required for the construction of the project, (e.g., - only small residue remains; dwelling, etc., taken by construction, and residue does not meet minimum requirements for reconstruction). These situations should be reviewed at the project [field inspection](#) and a decision regarding the property made at that time or during the right of way appraisal stage. When this occurs, the normal right of way line is to be established (clearly dimensioned) and labeled "Proposed Right of Way" and the residue property line(s) labeled "Proposed Acquisition Line" (See [Appendix C, Section C-3-RIGHT OF WAY](#)). By labeling the residue in this manner, the surplus property has been established and will be included in the Right of Way Division's "Residue Parcels Inventory" for disposal purposes.

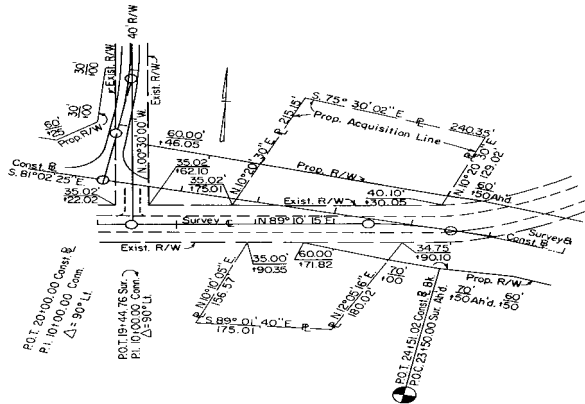

Right of Way breaks are to be shown as near as feasible to the applicable break, and lettered along a line parallel to the baseline. The distance from the baseline is to be shown above a solid line with the baseline plus below. When more than one baseline is used, the referenced line should be identified.

Proposed right of way is to be labeled on each side of the roadway at least once per plan sheet unless broken by a connection or relocation.

DETERMINING PROPOSED RIGHT OF WAY WITH SLOPE EASEMENTS

On most Urban projects, and in some other instances, it is desirable to acquire right of way only for the proposed roadway, buffer strips, and sidewalk. The proposed right of way line, in this case, is usually based on the computed back of sidewalk line or on a line parallel to the back of sidewalk.

DETERMINING SLOPE EASEMENTS

Permanent or temporary slope easements are acquired encompassing the area actually needed for slopes, plus a working area of approximately 1.5 m (5'). The need for maintaining the slopes following the completion of construction is to be determined at **Field Inspection**. Should continued maintenance be deemed necessary, then a permanent easement will be recommended. Otherwise, a temporary easement to terminate at the end of construction will be recommended.

The slope easement line is established spacing breaks similar to the method indicated previously in this section for right of way lines and is shown in a dot-dot-dashed medium weight line for temporary easements or dot-dashed line for permanent easements with the pluses and distances for the breaks shown in parentheses for temporary easements, or brackets for permanent easements. If an easement break falls on a right of way break, a separate easement break will also be shown.

A **note is to be shown** on each applicable plan sheet in a conspicuous location as follows:

"Note: Figures in parentheses and dot-dot-dashed lines denote temporary easements."

Or "Note: Figures in brackets, and dot-dashed lines denote permanent easements."

Or "Note: Figures in double brackets, and dot-dashed lines denote utility easements."

The usage of the easement will also be indicated on the plans (e.g. Prop. Temp. Slope Easement, Prop. Perm. Drainage Easement, etc.).

CONSTRUCTION EASEMENTS

Frequently, there are items located within the proposed construction easements, such as signs, light poles, steps, etc., which for some reason it is preferable to work around rather than remove. When it has been determined that certain items are not to be disturbed, this should be clearly noted on the plans so that the Right of Way Division will not purchase unnecessary items. These requirements are normally determined by the Right of Way Division.

DETERMINING PERMANENT EASEMENTS

Permanent easements are used where perpetual maintenance is required, such as slope easements as recommended by the District Administrator or where fee right of way is impractical, such as for ditches or pipes extending beyond the project limits. In these instances, the permanent easement is to generally parallel the item in question, clearing the construction limits by approximately 1.5 m (5') or a sufficient width for the required maintenance necessary.

The permanent easement lines are tied to the proposed right of way line and at necessary points around the periphery of the item in question, allowing adequate space for construction activity.

The permanent easement lines are to be dot-dashed and pluses and distances are shown in brackets. A [note](#) is to be shown, in a conspicuous location on each applicable plan sheet, as follows:

"Note: Figures in brackets and dot-dashed lines denote permanent easements."

The exact usage of the easement needs to be specified at each location, such as "Prop. Permanent Easement for Installation and Maintenance of Prop. Drainage Structure" or "Prop. Permanent Easement for Construction and Maintenance of Prop. Drain Ditch." If space is not available in the area of the easement, label the easement "Proposed Permanent Easement" with an asterisk (or similar notation) and show a note detailing the exact usage of the easement at another location on the sheet. Highway aerial easements are to be shown similar to the drainage easements and labeled "Proposed Aerial Easement for Bridge" and, if necessary, asterisks (or similar notations) are to be shown on all applicable easement breaks to distinguish the easement from other easements in the area.

In cases where permanent and temporary easement requirements overlap, the permanent easement takes precedence over the temporary easement; therefore, a temporary easement is to be tied into the permanent easement, not run through it. In some cases, a temporary construction easement will be necessary to generally run parallel to the permanent easement to provide adequate working and storage space. Where this is necessary, the temporary construction easement is to be shown, in its entirety, as the previously mentioned temporary slope easements and labeled "Prop. Temporary Construction Easement."

Easements that run away from the roadway (generally perpendicular) are to be dimensioned by pluses and distances to each corner.

UTILITY EASEMENTS

In the past, utility easements have not been identified on public hearing plans. Following the public hearing and even as late as construction, concerns have been raised that citizens have not always been informed that utility easements may be added after the public hearing.

Discuss the necessity of showing preliminary utility easements on project plans at the [scoping stage](#) and at [field inspection](#). Strong consideration should be given to showing proposed preliminary easements on project plans in residential areas prior to the willingness and public hearing stage.

The field inspection recommendation regarding inclusion of preliminary utility easements should be reviewed with the appropriate Assistant L & D Engineer or District Location and Design Engineer.

If the decision is made to add preliminary utility easements on the project plans, three sets of prints will be furnished by the designer to the District Utility Engineer along with a written request to develop preliminary utility easements for the public hearing stage. The date this information will be needed to meet the public hearing schedule will be included in the request.

If the decision is made not to add preliminary easements on the project plans, the appropriate plan note (note B) is to be shown on prints for the willingness, public hearing and prints furnished outside the department.

When the preliminary utility easement information is received from the utility section, they are to be shown on prints for the [willingness or public hearing](#) and prints furnished outside of the department along with the appropriate plan [note](#).

After the utility field inspection and before submission of approved right of way plans, detailed utility easement information will be provided by the Right of Way Division and shown on original plan sheets.

Notes A or B shall be removed from plans after the public hearing stage prior to submitting plans for right of way.

The following note should be shown on the title sheet and all plan sheets when preliminary easements are shown on plans.

NOTE A

PRELIMINARY EASEMENTS FOR UTILITY RELOCATIONS
ARE APPROXIMATE ONLY AND SUBJECT TO CHANGES
AS PROJECT DESIGN IS FINALIZED

When the decision is made not to add preliminary easements the following note is to be shown.

NOTE B

ADDITIONAL EASEMENTS FOR UTILITY RELOCATIONS
MAY BE REQUIRED BEYOND THE PROPOSED RIGHT OF
WAY SHOWN ON THE PLANS

One of the above notes should be shown on all prints for the willingness or public hearing stage and prints furnished outside the Department.

On prints for public hearing or willingness and prints furnished outside the Department, shade in yellow with highlighting marker, the above notes for additional emphasis.

A discussion concerning possible additional or adjusted utility easements shall be included in:

[Engineering presentation](#)
[Public Hearing handout/booklet](#)

The following are examples of how this discussion may be worded:

- (1) When preliminary easements are shown on project.

"As we further coordinate and finalize project development, preliminary utility easement locations shown on public hearing plans may change. The property owner will be informed of the exact location of the easements during the right of way acquisition process and prior to construction."

- (2) When preliminary easements are not shown on project.

"As we further coordinate and finalize project development, additional easements for utility relocations may be required beyond the proposed right of way shown on the public hearing plans. The property owner will be informed of the exact location of the easements during the right of way acquisition process and prior to construction."

Detailed utility easements requirements are determined by the District Utility Engineer after the Utility Field Inspection (Chapter 2E, Section 2E-13) has been conducted. The District Utility Engineer will furnish marked prints to the designer showing the utility easements which are to be shown on the plans. If this information is received prior to approved right of way plans, it is included as a part of those plans. Otherwise, it must be added as a revision to the approved right of way plans.

Marked plans furnished, showing the necessary easements, shall contain the appropriate note indicating type (standard or trim and overhang) and for which utility company the easement is being acquired. There are instances where joint use utility easements are proposed. In those cases, all companies are to be shown. Utility easements are separate from any other permanent or temporary easement and are not to be broken where they cross these other easements. They are to be stopped at any location where they intersect the proposed or existing right of way line.

The marked prints of utility easements shall contain adequate information to incorporate the utility easement into the plans. When a utility easement is parallel to the proposed right of way line and is of a consistent width, it is not necessary for the marked prints to show pluses and distances. The designer shall show and/or calculate the appropriate break points. For easements that are not parallel, the marked prints shall contain sufficient information for the designer to add the utility easements to the plans. (i.e. pluses and distances or distances on a property line). All easements must mathematically close.

The utility easement lines are to be dot-dashed with pluses and distances shown in double brackets [[-]]. Each line is to be labeled as to type and utility company. Parallel utility easements 1.5 m (5') apart or closer should be questioned. Normally these lines should be combined into a joint easement at the wider width; however, the District Utility Engineer should be consulted before making that change.

Once the right of way acquisition process has begun, requests for easement revisions must originate with or be coordinated with the District Right of Way office.

For utility easements, an appropriate note is to be shown on each plan sheet which contains an easement, using appropriate notes as furnished by the Right of Way Division and symbols as shown in the CADD Manual.

LIMITED ACCESS LINES

Where limited access lines coincide with proposed right of way lines, the common line is to be labeled "[Proposed Right of Way and Limited Access Line](#)" with breaks shown as previously described for proposed right of way.

Where limited access lines deviate from proposed right of way, they are to be shown as dashed lines and are to be labeled "Proposed Limited Access Line."

Proposed limited access lines are to be continuous for the length of the project, except at interchanges. Where frontage roads are provided, the limited access line is to tie to the proposed right of way line at appropriate points and usually run parallel to and between the frontage road and mainline. Where applicable, the limited access line is to be labeled: "Proposed Limited Access Line (insert distance) from and parallel to Frontage Road Baseline."

At interchanges, the limited access lines are to encompass the entire periphery of the interchanges and should extend beyond the ramp terminals a minimum of 30 m (100') in urban areas and 90 m (300') in rural areas. (See Figure 2E-9). These distances usually satisfy any congestion concerns. However, in areas where the potential for development exists which would create traffic problems, it may be appropriate to consider longer lengths of access control. The beginning and ending points of limited access lines are to be flagged with "Begin" and "End Limited Access" with stations referenced to the connecting road. Limited access lines are to be broken and flagged with stations based on the mainline at grade separations.

Unless specifically advised to the contrary by the Right of Way and Utilities Division, begin and end limited access is to be flagged only at or near the beginning and end of the right of way project and at interchanges and grade separations as previously noted.

On all projects designated as "Limited Access Highways", the date of the resolution passed by the commission, Board, etc., and the words "LIMITED ACCESS HIGHWAY" are to be [shown above the project block](#) on the title sheet and on each plan sheet. This is applicable to all new projects and also to all projects involving previously designated "Limited Access Highways".

Over the years the "Highway Commission" has been updated to the "State Highway and Transportation Commission", the "State Highway and Transportation Board" and as of January 1, 1987, is the "Commonwealth Transportation Board".

Following are the notes that are to be used along with the applicable project situations:

(1) LIMITED ACCESS HIGHWAY By Resolution of Commonwealth Transportation Board dated _____.

All projects designated after December 31, 1986 by "Commonwealth Transportation Board" (includes interstate and other highways that tied the original L/A line down by stations and thereby, require a new resolution)

(2) LIMITED ACCESS HIGHWAY By Resolution of Highway Commission dated _____.

All interstate highways and all highways previously designated by "Highway Commission".

DEPICTING LIMITED ACCESS RIGHT OF WAY

The method of designating Right of Way on a proposed limited access project should be as indicated in Figures 2E-9 and 2E-10. Unusual conditions, not covered by these examples, may require individual study and should be discussed at Field Inspection.

SEPARATE RIGHT OF WAY PLANS

If plan sheets are extremely congested with topography, etc., separate right of way plans may be justified. This determination is to be made by the Engineer in charge of the project design.

PROPERTY REQUIRING METES AND BOUNDS DESCRIPTION

Complete [metes and bounds](#) information is to be included in the approved right of way plan assembly for projects requiring procurement of property from unique clients (e.g. Federal and State governmental agencies, railways and Power companies). This requirement shall apply to all land and permanent easement acquisitions. It is not necessary to provide metes and bounds descriptions for temporary construction easements. Temporary construction easements shall be designated with conventional plus and distance on the breaks and acreage of take.

This information is to be shown on a "METES AND BOUNDS" sheet included in the approved right of way plan assemblies for applicable projects as a "1 series" sheet. Information shown shall include property owner names (including adjacent parcels), utility company names (e.g. Bell Atlantic, Virginia Power, Hampton Roads Sanitation District, etc.) types of easement (permanent drainage, permanent utility, temporary construction, etc.) property lines, right of way and easement lines (proposed and existing), centerline/baseline identification with stationing, bearings, lengths, curve data, and acreage of take. Right of way and permanent easement takes on radius are to show chord length, chord bearing, arc length, and radius.

The Metes and Bounds closure is to be calculated in a clockwise direction, with all break points labeled and information (bearings, lengths, curve data) shown in tabular form on the Metes and Bounds sheet. The point of beginning for each parcel will be a readily identifiable point, such as an iron pin, Right of Way monument or reference to the Construction Baseline. Deed records for railroad properties are to be referenced from a railroad mile post and tied specifically to railroad track stationing. The Metes and Bounds sheet should have sufficient descriptive detail to be used independent of the construction plan sheets; however, construction plans and Metes and Bounds sheets should reference each other for supplemental information.

A separate metes and bounds sheet may not be needed on non-complex projects, provided data can be shown legibly on the roadway plan sheet.

The District Survey Sections (or Central Office Survey Section) shall confirm that the metes and bounds are shown correctly. The road designer shall furnish any available original property line back up information to the Survey Section for this review. At the completion of the review, the road designer shall furnish the sheet to the Right of Way and Utilities Division, normally, as part of the approved right of way plan assembly for their use in preparing the deed description. (See sample Metes and Bounds Sheet 2E-9).

Some Federal agencies prefer that only a single roadway easement be shown, rather than separate easements for roadway, drainage, stormwater management or other types of permanent easement. It would be advantageous to the designer to contact the Right of Way and Utilities Division's Special Negotiations Section (804-786-2986) for directions prior to determining right of way requirements.

METES AND BOUNDS
FOR COMMONWEALTH OF VA.
NATIONAL GUARD

DESIGN FEATURES RELATING TO CONSTRUCTION OR TO REGULATION AND CONTROL OF TRAFFIC MAY BE SUBJECT TO CHANGE AS DEEMED NECESSARY BY THE DEPARTMENT

DATE	BY	REVISION	DATE	BY	REVISION
6-15-92					
	1	NA			
			58	0058-134-103, RW	202
				C-502	
					ID

AREA 1 PERMANENT DRAINAGE EASEMENT

LINE	BEARING	LENGTH	RADIUS
Ⓐ	N76°00'20"E	111.13'	
Ⓐ	N76°00'20"E	12.28'	
Ⓐ	S14°30'47"E	6.16'	
Ⓐ	S76°00'20"W	12.28'	
Ⓐ	N14°30'47"W	6.16'	

TOTAL ACREAGE = 0.002 ACRE

AREA 7, PARCEL 002 FEE RIGHT OF WAY

LINE	BEARING	LENGTH	RADIUS
Ⓐ	N76°00'20"W	175.89'	
Ⓐ	S67°26'50"E	105.16'	
Ⓐ	CHORD		319.30'
Ⓐ	S65°05'17"W	144.82'	
Ⓐ	S76°00'20"W	16.36'	
Ⓐ	S76°00'20"W	102.00'	
Ⓐ	N14°30'47"W	95.00'	

TOTAL ACREAGE = 0.470 ACRE

AREA 2 UNDERGROUND UTILITY EASEMENT FOR CITY OF NORFOLK

LINE	BEARING	LENGTH	RADIUS
Ⓐ	N76°00'20"E	123.41'	
Ⓐ	S14°30'47"W	10.00'	
Ⓐ	S76°00'20"W	123.56'	
Ⓐ	N37°39'40"W	10.10'	

TOTAL ACREAGE = 0.027 ACRE

AREA 4 PERMANENT DRAINAGE EASEMENT

LINE	BEARING	LENGTH	RADIUS
Ⓐ	S14°30'47"E	85.00'	
Ⓐ	S75°50'50"W	10.00'	
Ⓐ	N04°30'47"W	85.00'	
Ⓐ	N75°52'50"E	10.00'	

TOTAL ACREAGE = 0.020 ACRE

AREA 5 PERMANENT DRAINAGE EASEMENT

LINE	BEARING	LENGTH	RADIUS
Ⓐ	S14°30'47"E	95.00'	
Ⓐ	N76°00'20"E	77.00'	
Ⓐ	N76°00'20"E	25.00'	
Ⓐ	S06°13'05"W	40.50'	
Ⓐ	S75°59'26"W	11.00'	
Ⓐ	N04°00'31"W	38.00'	

TOTAL ACREAGE = 0.016 ACRE

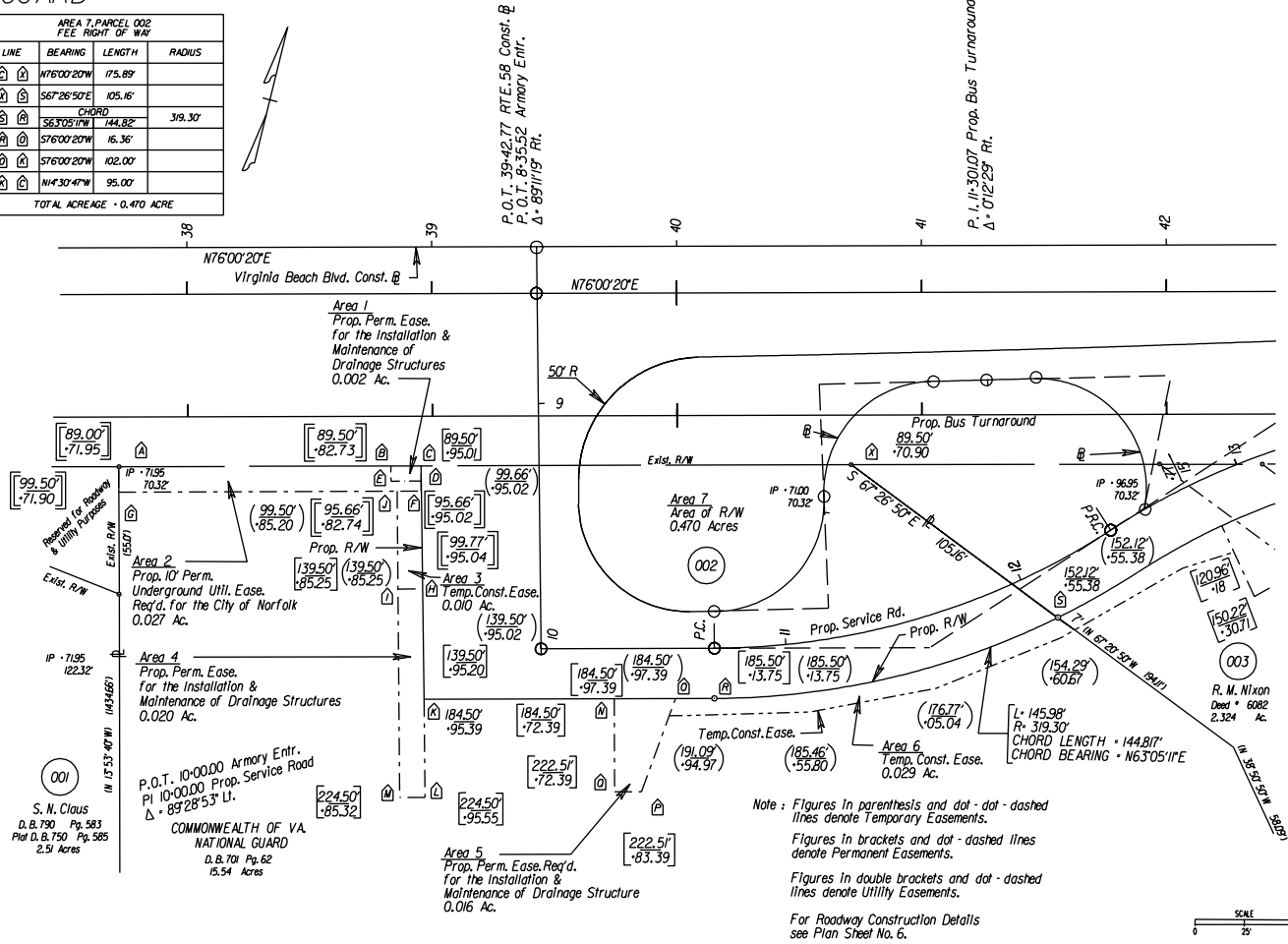

FIGURE 2E-9 SAMPLE METES AND BOUNDS SHEET

0058-134-103	ID
--------------	----

RIGHT OF WAY DESCRIPTION FURNISHED TO ENVIRONMENTAL DIVISION

The environmental planning process requires that the following right of way data must be furnished to the Environmental Quality Engineer upon request for an environmental document.

1. Both a right of way description and estimate of total right of way area will be included in all categorical exclusions and Environmental Assessment Documents.
2. The U.S. Farmland Protection Act requires that all federally funded highway projects be coordinated with the U.S. Soil Conservation Services to determine impact, if any, upon Farmlands. The process for coordination with the U.S. Soil Conservation Service requires that an estimate of the area of right of way for all projects be provided to the district conservationist.

"Right of Way", regarding the description and area, is defined as fee-simple right of way, temporary and permanent easements and donations of lands. Specify if the land required for "Right of Way" is developed residential, commercial, and/or industrial.

The following are example statements describing the right-of-way for an environmental assessment.

1. Less than 3 m (10') strips on both sides of the roadway for the length of the project.
2. Less than 2 ha (5 acres) for widening and removal of several hairpin curves.
3. Approximately 1 ha (2 acres) of right of way and easements for constructing bridge and improving 300 m (1,000') of approaches.

There are other situations which will require right of way descriptions and area estimates other than the above examples.

The area can be just a rough approximation of the combined right of way, easements, etc., and should entail only a minimum amount of calculation. This area will be helpful to the FHWA in deciding whether more than minor amounts of right of way are involved.

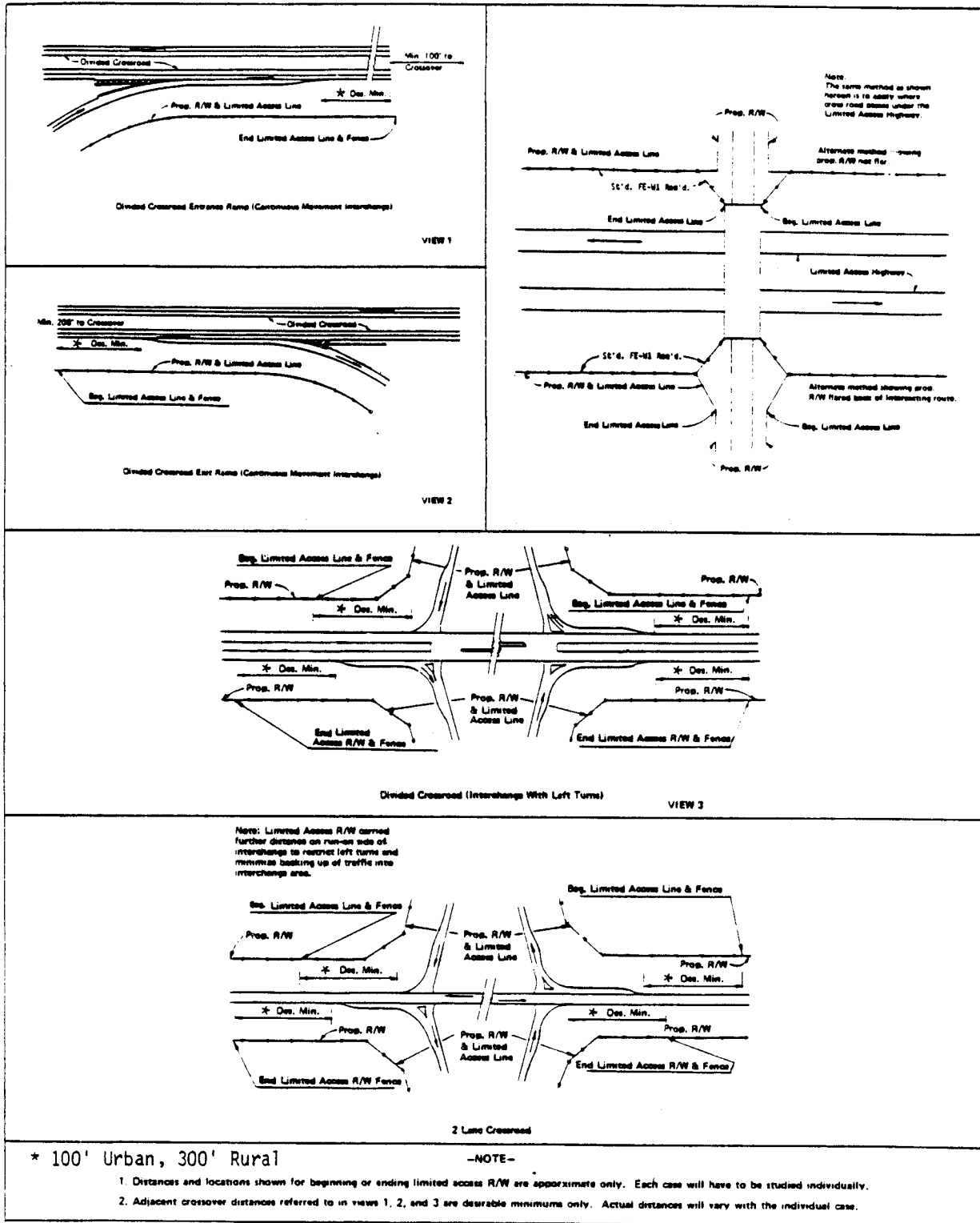

FIGURE 2E-10 DEPICTING LIMITED ACCESS RIGHT-OF-WAY

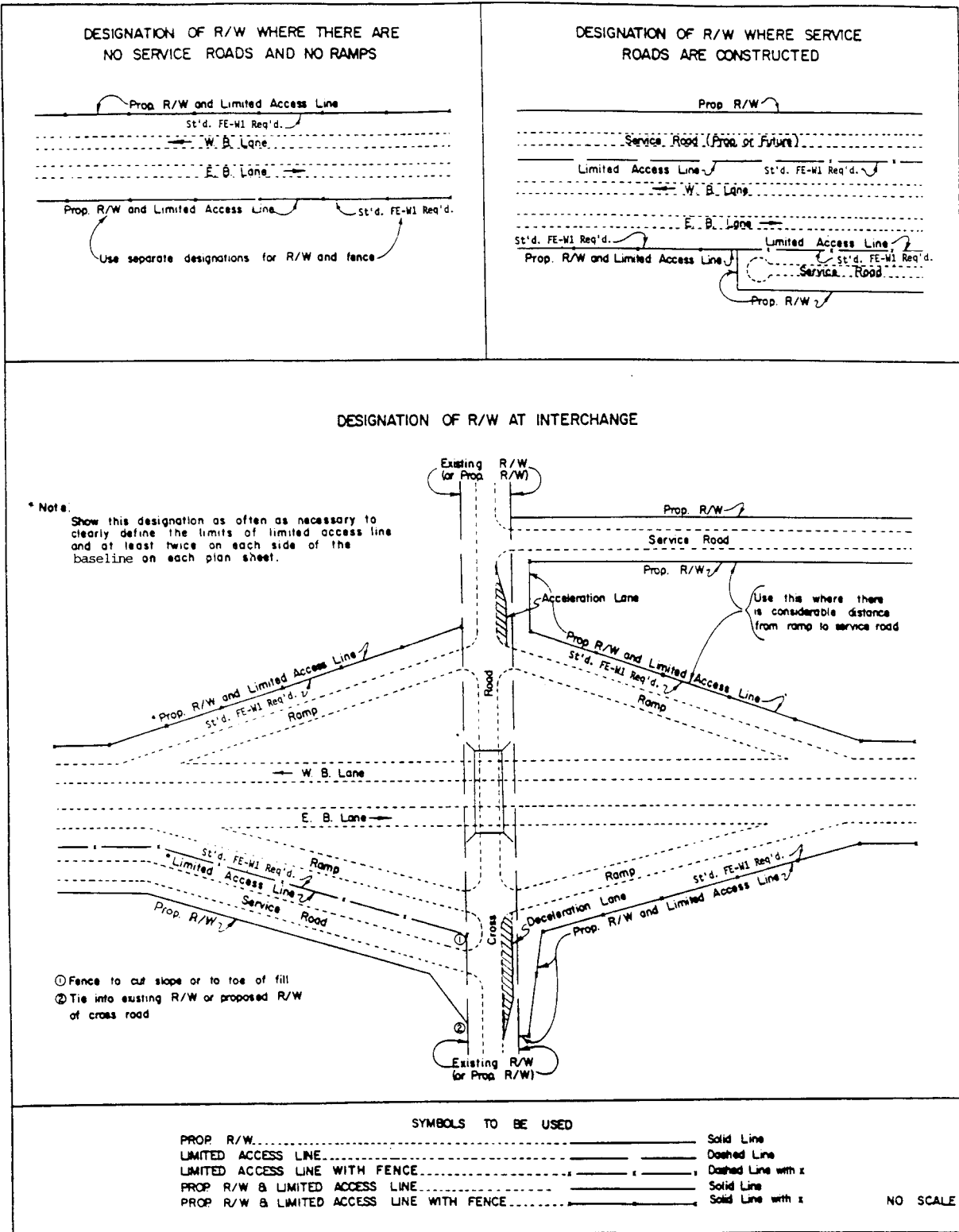

FIGURE 2E-10 DEPICTING LIMITED ACCESS RIGHT-OF-WAY

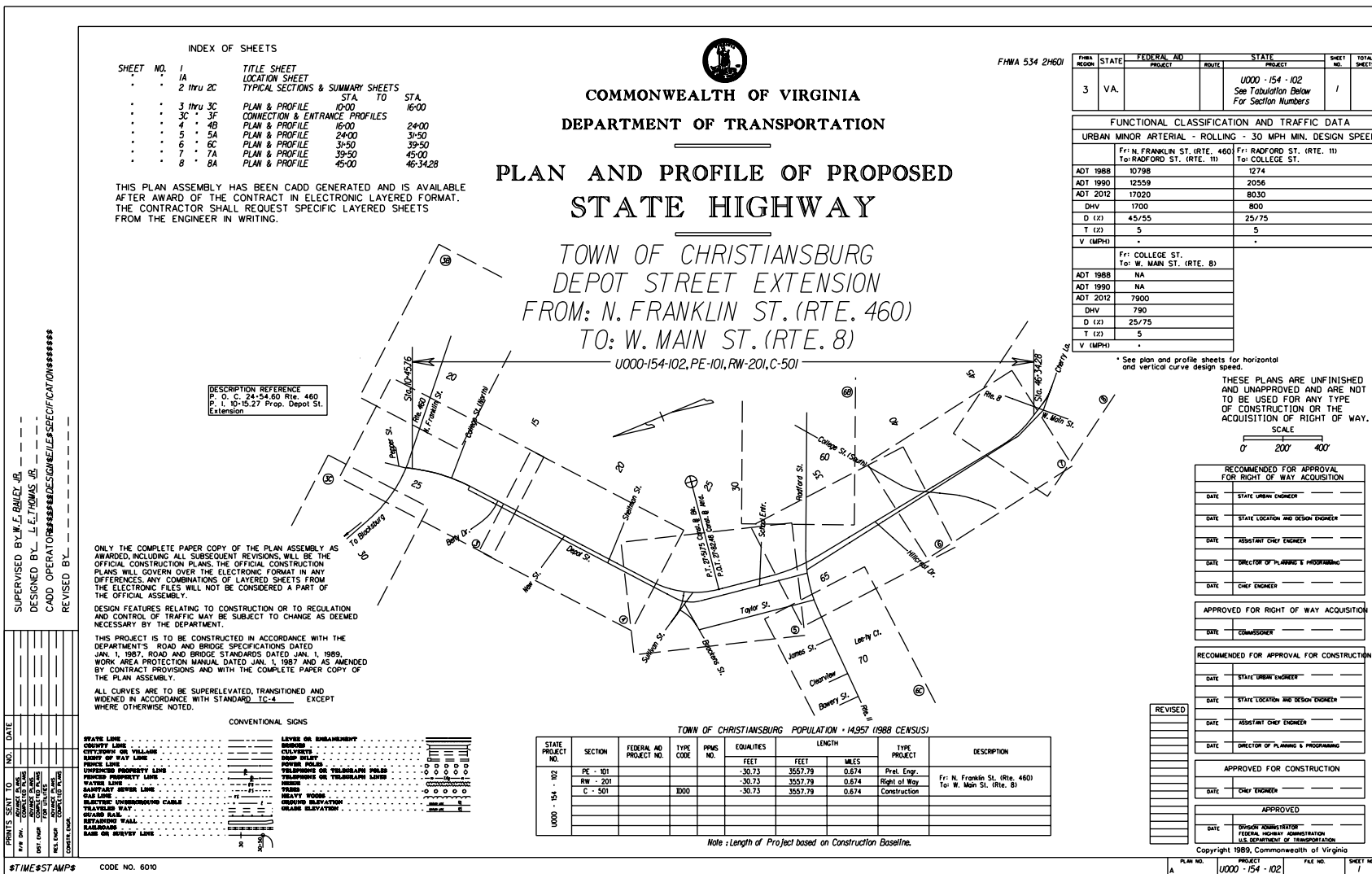

FIGURE 2E-11 SAMPLE TITLE SHEET (URBAN DESIGN)

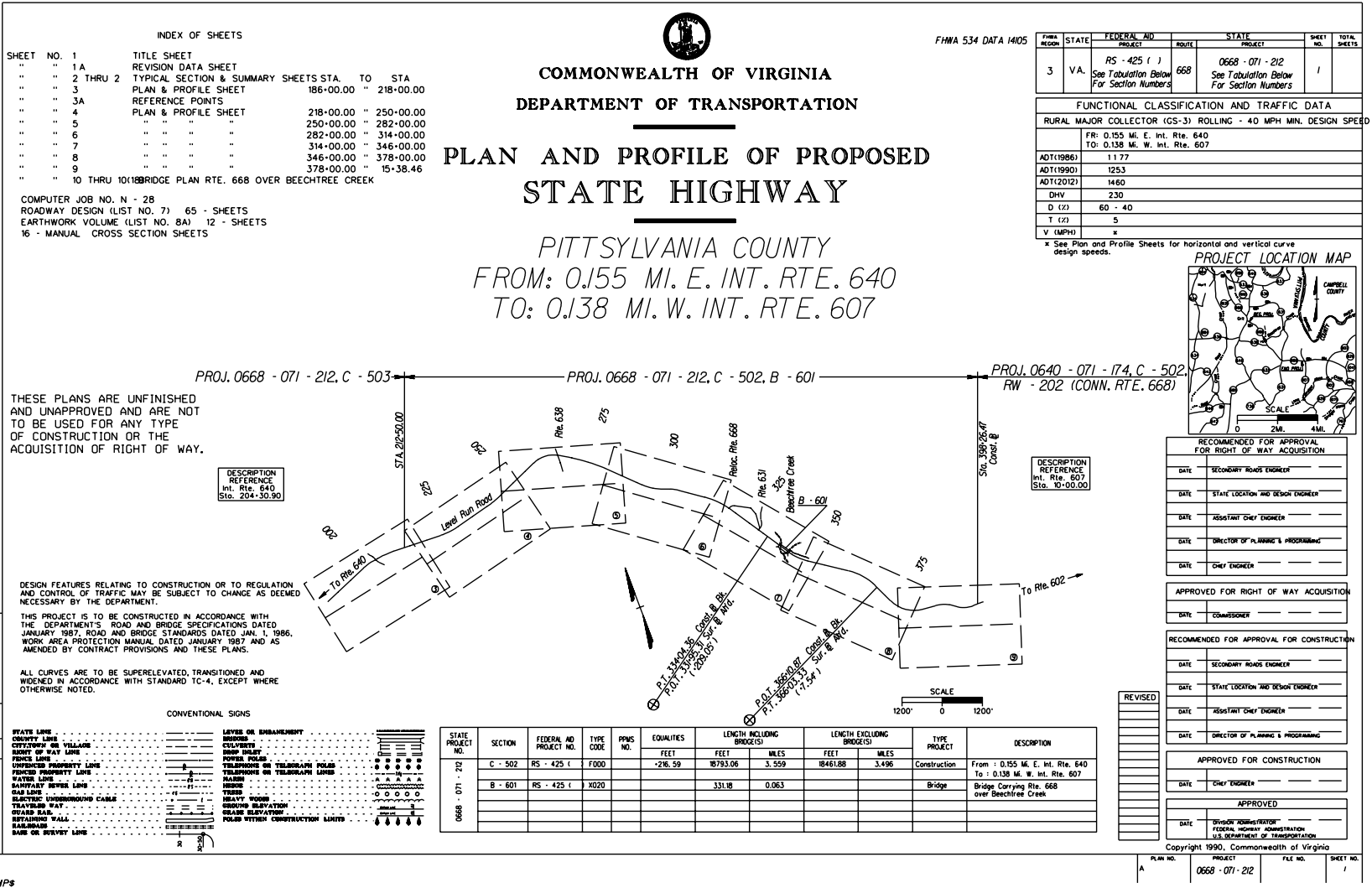

FIGURE 2E-12 SAMPLE TITLE SHEET (SECONDARD DESIGN)

SUPERVISED BY: S.C. Ward
DESIGNED BY: H.B. Moran - Lynchburg Dist.
CADD OPERATOR: DESSIGNE FILE & SPECIFICATIONS
REVISED BY:

PRINTS SENT TO	NO.	DATE

STIME&STAMPS

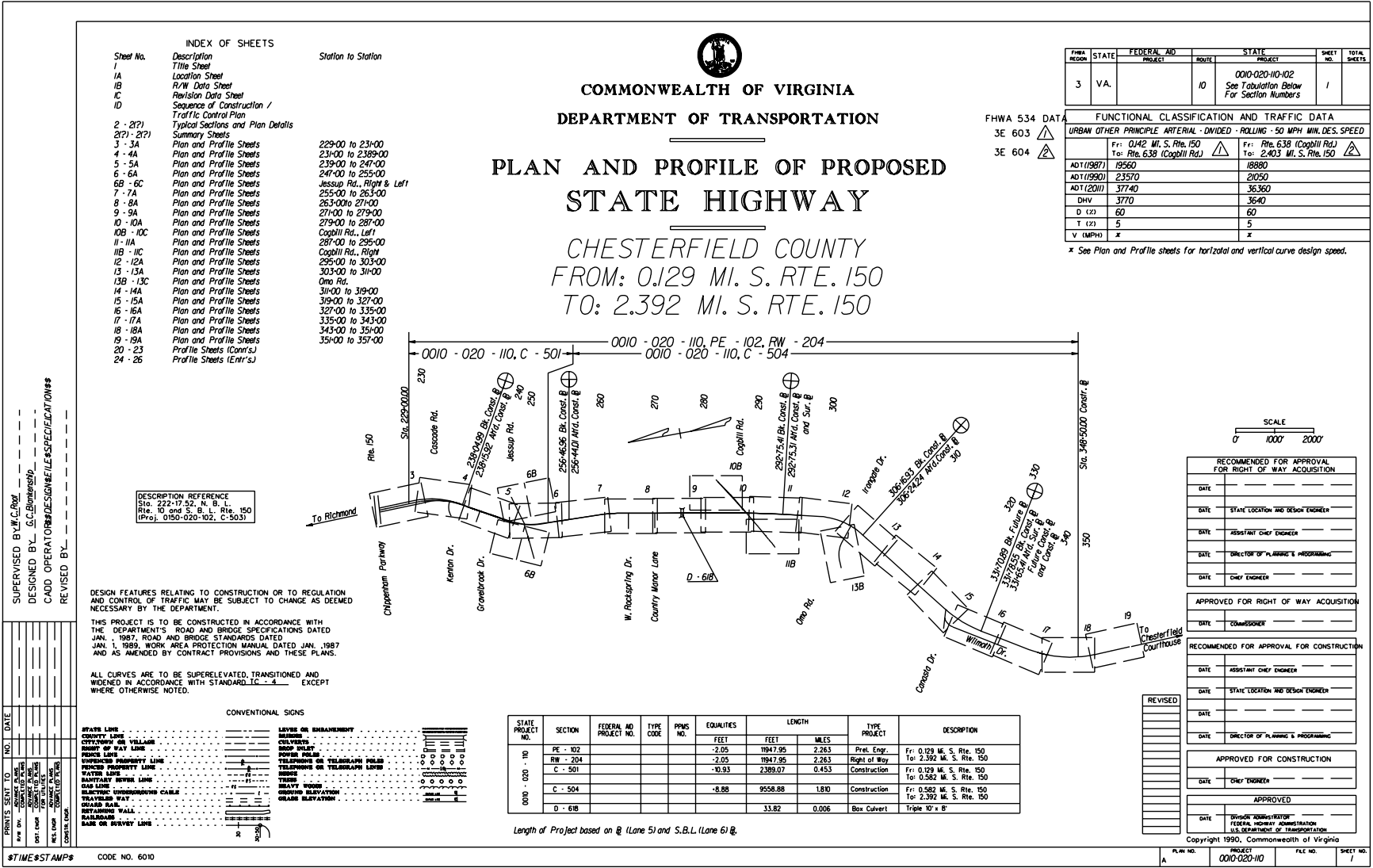

FIGURE 2E-13 SAMPLE TITLE SHEET (PRIMARY)

PLAN REVISIONS

When a request is made to revise plans that would change a proposed right of way line or proposed easement, the request should indicate to the designer if the property has already been acquired. If so, the original proposed right of way line or proposed easement is not to be removed from the plans and is to be designated as follows:

"Orig. Proposed Right of Way" or "Orig. Proposed type of easement". Label the revised right of way or easement lines "Rev. Prop. Right of Way (date)" or "Rev. Prop. type of easement and (date)," respectively.

SECTION 2E - 6 - PREPARATION OF SUPPLEMENTAL SHEETS

TITLE SHEET (SEE FIGURES 2E - 11, 2E - 12, & 2E - 13)

A title sheet is to be prepared generally for each project or group of projects previously determined to be advertised simultaneously. The basic sheet is to be adapted to all uses (such as limited access, urban projects, secondary projects, etc.)

IDENTIFICATION

The project base number(s) on all projects are to be shown in the block provided in the upper right corner of the title sheet. For Federal projects, an identifier will be added as a prefix to the project number on the title sheet. This identifier will be (FO) for projects with Federal Oversight and (NFO) for projects with No Federal Oversight. Federal-Aid number(s), when applicable, will be shown in this block (on the title sheet only), showing the parentheses without numbers within. All project numbers are to be referenced with a note to "see the project length tabulation block". The project base number(s) are to be shown in the block provided in the lower right corner of the sheet. The Federal-Aid number is to appear on the title sheet only.

See Example below:

STATE	FEDERAL AID	STATE		SHEET NO.
	PROJECT	ROUTE	PROJECT	
VA.	RS - 425 () SEE Tabulation Below For Section Numbers	668	(FO)0668-071-112 SEE Tabulation Below For Section Numbers	1

The [Highway Capital Outlay Code \(FHWA-534\)](#) is to be shown on the title sheet in the upper right-hand corner to the left of the project number block. (See IIM LD- 151 for further instructions).

The title sheet is always [numbered "1"](#).

The Designer's name and phone number (including area code) is to be shown in the middle left margin in the space provided. The Supervisor's name is to be shown directly above the Designer's name.

[Copyright date](#) is to be shown directly below the signature blocks in the lower right corner. (See IIM LD-186).

For [additional notes](#) to be shown on the title sheet, See IIM LD- 110.

The appropriate TC-5.01 designation (TC-5.01ULS, TC-5.01U, or TC-5.01R) must be shown on the title sheet.

LAYOUT

A layout of the project limits is to be plotted depicting the existing baseline of the mainline roadway, interchanges, connections, railroads, rivers, major (usually named) streams, and major landmarks. Street names, as well as route numbers, are to be shown where applicable. These items are to be labeled in accordance with the [CADD Users Guide](#) with destination for the mainline, connections, and railroads. Flow arrows are to be shown for rivers, etc..

The layout is to be plotted to a reasonable scale large enough to utilize the space provided but not so large as to encroach on other items (index, project tabulation, etc.).

[Description reference blocks](#) are to be shown to coincide with the project description and previous projects.

The number of and distance to the nearest railroad mile post is to be shown if the project crosses or involves a railroad.

A heavy solid line is to be shown depicting the proposed mainline, connections, ramps, frontage roads, etc., with station marks shown at appropriate intervals depending upon the length of the project.

[Station numbers](#) are to be shown above the station marks in accordance with the [CADD Users Guide](#) readable from the right end of the sheet.

[Equalities](#) are to be shown, where applicable to the project length, with symbols similar to previous instructions for plan sheets. (See Figure 2E-12).

[Light dashed lines](#) are to be shown over the layout delineating the limits of each plan sheet with the corresponding sheet numbers shown within light dashed circles.

Proposed bridges, culverts, or other items requiring "B" or "D" numbers are to be clearly shown and labeled in accordance with the with the applicable "B" or "D" number. (See Project Length Tabulation, this section)

Interchange ramps are to be labeled with the description used on the plans. (Ramp "A", etc.)

Vertical lines are to be projected upward from the begin and end project points with the applicable [State project numbers](#) shown in accordance with the [CADD Users Guide](#) along horizontal lines between them. Begin and end project station numbers are to be shown in

accordance with the CADD Users Guide along the vertical lines. If the preliminary engineering project limits extend beyond the normal project limits, the arrows for the PE numbers are to extend beyond the vertical lines indicating continuation of the project.

Tie-in project numbers are to be shown on each end of the project, where applicable, showing status such as "Under Const.", "Under Design", etc..

A north arrow and bar scale are to be shown in conspicuous locations with the scale in the lower center or right area of the layout.

DESCRIPTION

The **county or city name** is to be shown in the center of the title sheet, directly below the line under the large pre-printed title. Directly below this line, centered horizontally, is shown the project description, with distances from intersections, etc., shown to the nearest thousandth of a kilometer (mile).

If a **"from" and "to"** description is used, "from" is shown on the top line and "to" on the bottom. Descriptions are to be referenced from items such as county or city lines, primary routes, secondary routes, rivers or major streams, railroads, etc.

In cases where the mainline has a designated commonly used street name, it is to be shown between the county or city name and the description.

PROJECT LENGTH TABULATION

A block is to be provided in the lower center of the title sheet for the following information (Show in accordance with the CADD Users Guide where practicable):

State Project No." - Listing of applicable state project base numbers

Section" - Listing of various section numbers such as "PE-101", (if the PE number extends beyond the limits shown on the layout, no reference is to be made in the length tabulation) "RW-201", "G-301", "P-401", "C-501", "B-601", etc.

"Federal Project No." - Listing of complete Federal project number

"Type Code No."- Listing of applicable Type Code Nos. such as "F000", "I000", "K000", etc.

"P/PMS No." - Listing of applicable P/PMS Nos. "

"Equalities in meters (feet)" - Listing of equality lengths, whether "+" or "-" for the various sections. If none, the word "none" is to be shown.

"Exceptions, meters (feet) - Listing of exception lengths where applicable "Length, meters (feet), kilometers (miles)" - Listing of lengths of various roadway sections - to be shown to the nearest hundredth of a meter (foot) and nearest thousandth of a kilometer (mile); "Length Including Bridges", "Length Excluding Bridges", listing of bridge lengths based on the same line as the roadway lengths and affecting the roadway lengths; "Length Including Box Culverts", "Length Excluding Box Culverts", listing of box culvert lengths based on the same line as the roadway lengths and affecting the roadway lengths. (Only where traffic is placed directly on the top slab of the box culvert). All "B" and "D" projects are to be shown in the length tabulation block, but are to be included in the headings of the length columns only where they affect the roadway project length.

"Type Project" - Listing of project types such as: "Preliminary Engr.", "Right of Way", "Grading", "Paving", "Construction", "Bridge", etc.

"Description" - Listing of various section descriptions. See example:

STATE PROJECT NO.	SECTION	FEDERAL AD PROJECT NO.	TYPE CODE	PPMS NO.	EQUALITIES	LENGTH INCLUDING BRIDGES		LENGTH INCLUDING BRIDGES		TYPE PROJECT	DESCRIPTION
					FEET	FEET	MILES	FEET	MILES		
0668-071-202	C-502	RS-425 ()	F000	559	205.59	18,793.06	3.559	18,461.88	3.496	CONSTR.	From: 0155 Mi. E. Rte. 640
											To: 0138 Mi. W. Rte. 807
	B-601	RS-425 ()	X020	425	3.311	0.063					Bridge Carrying Rte. 668 over Peachtree Creek

The following codes will be used for all drainage structures measuring over 6 m (20 feet) along the centerline between the inner faces of the outer walls(as defined by 23 CFR 650 © National Bridge Standards, Section 650.301, Application of Standards). Such structures are classed as major structures and are to be set up as separate projects with separate lengths. Multiple lines of two or more pipes will be considered a "major structure" if the clear distance between the outer walls is more than the radius of the smaller pipe (or half the width of arch or elliptical pipes) of any two adjacent pipes in the group combination. The Structure & Bridge Division should be consulted in instances where the application of this guideline requires interpretation. The stations and length used on the plans for such a culvert shall be based on the distance between the back of the outside walls, not on the distance between the faces of same. Separate quantities are to be shown on the plans and estimates for these structures. In cases where the roadway and surfacing is carried over but is not a part of the structure, the roadway and surfacing quantities are not separated on the plans and estimates, but are included in the roadway project.

If no work is proposed on an existing major structure, it should not be set up as a separate project, but shown as an exception to the roadway project. Minor structures of less than 6 m (20'), however, should never be shown as exceptions.

"B" PREFIX

Special Design Bridges
 Standard Slab Span Bridges
 Special Design Box Culverts
 Special Design Rigid Frames
 Special Design Arches

"D" PREFIX

Standard Box Culverts
 Multiple Line Pipe Culverts

The identification numbers are to be requested using Form LD-219 and will be assigned initially in sequence, without regard to the prefix "B" or "D"; i.e. B-601, B-602, D-603, D-604, B-605, etc. Construction Type Codes for roadway and surface type, bridge type (includes culverts - any type box or culvert), and miscellaneous type construction are required for each construction section on all projects, e.g., C-501, B-601, D-602, C-502, L-801, S-901, etc. The Type Codes, as noted in Figure 2E-14, are required on the plans and are to be shown on the title sheet in the project length tabulation block adjacent to the Federal-Aid Project number block (regardless of whether the project is federally funded) for the applicable Section Number.

No Plan and Minimum Plan project Type Codes are to be shown on the title or cover sheet and are to be handled in variations of the above procedure, as required. This is also to apply to project plans, such as Landscape, Signs, etc., prepared by other divisions, that do not require road plans.

The Bridge Type Code is noted on the bridge plan cover sheet in the upper right hand border beside the project block and also on their final review transmittal Form B-45A or B-45B adjacent to the copy transmittal listing to the FHWA as - Bridge Type Code: X.

The Type Code is also to be shown in the Engineering Estimate.

FUNCTIONAL CLASSIFICATION - TRAFFIC DATA

A block is to be shown in the upper right corner below the project number block listing the class or type of road, whether divided or undivided roadways and type of terrain (level, rolling, or mountainous). See IIM LD-110 for further instructions. Traffic data is listed below this information, in the same block, as furnished to this Division by the Traffic Engineering Division on Form No. TS-25, or from the Transportation Planning Division on Form No. TPD-1A. Exceptions to design speed are to be noted as shown in Section [2D-8 DESIGN EXCEPTIONS](#).

NOTES

Notes are to be shown in the lower left corner of each title sheet furnishing curve superelevation data, specifications and standards data, and the "design features" note as shown in Section 2D-10.

A note is to be shown directly above the length tabulation block detailing the method used in computing project lengths, such as:

"Note: Lengths are based on Route 00 Survey baseline between Sta. 00+00.00 and Sta. 10+00.00 and on Off. Rev. baseline between Sta. 10+00.00 and Sta. 20+00.00."

A note is to be shown in a conspicuous location, within municipality boundaries, showing the name of the municipality, population, and census year.

Project Location Map (Secondary Projects)

On Secondary Projects the project location map is to be shown in the upper right corner and is to show sufficient surrounding area to provide obvious location of the proposed project. (See Figure 2E-12)

WORK CLASS

P	Planning (HPR/PR)	1	Preliminary Engineering
R	Research (HPR/PR)	2	Right of Way
T	Transit Related or Training	3	Construction

2/ ROADWAY AND SURFACE WORK TYPES

A000	Primitive	G000	Mixed Bituminous
B000	Unimproved Penetration	H000	Bituminous
C000	Graded and Drained Earth Concrete	I000	Bituminous
D000	Soil Surface Conc.	J000	Portland Cement
E000	Gravel or Stone	K000	All others
F000	Bituminous Surface Treatment		

Notes: All bituminous Surface Types to be Asphalt in Virginia

2/ BRIDGE WORK TYPE

X_ _ _ The first digit (code X) indicates bridge class
The second digit indicates nature of structure

XO_ _ Highway over waterway
X1_ _ Highway over railroad
X2_ _ Highway project over highway
X3_ _ Highway over waterway and railroad
X4_ _ Highway over waterway and highway
X5_ _ Highway project over railroad and highway
X6_ _ Highway under railroad
X7_ _ Highway project under highway
X8_ _ Highway project under railroad and highway
X9_ _ Other combination, including Highway over waterway, RR and highway also 3- and 4- level grade separations and miscellaneous.

The third digit identifies the material of principal supporting members of the span.

X_0_	Timber
X_1_	Masonry
X_2_	Concrete, not prestressed
X_3_	Steel
X_4_	Steel and concrete
X_5_	Timber and steel
X_6_	Timber and concrete
X_7_	Composite steel and concrete
X_8_	Concrete, prestressed
X_9_	Aluminum

The fourth digit identifies type of span (identifies main span type
if bridge comprises 2 or more span types)

X_ _0	Slab
X_ _1	Girder
X_ _2	Truss (except cantilever)
X_ _3	Rigid frame
X_ _4	Arch
X_ _5	Cantilever truss
X_ _6	Movable
X_ _7	Suspension
X_ _8	Box Culvert (bridge length) (any type Box or Pipe Culvert)
X999	Highway tunnel

2/ Roadway and surface type and bridge types:
First digit is alpha, remaining digits are numeric

SUPERVISING AGENCY

S – State
D – FHWA Direct Federal Construction

1/ MISCELLANEOUS WORK TYPE CODES

Y000	Miscellaneous (must have approval from FHWA, Washington Office)
Y002	Traffic Signs
Y003	Landscaping (planting and related work)
Y004	All clearing (includes acquisition or removal of advertising signs, acquisition of property rights-junk yards, removal or relocation)
Y005	Planting of Wildflowers
Y007	Minor structure, (storm sewers, culverts, snowshed, etc.)
Y008	Channelization of traffic
Y009	Slope stabilization/slide protection
Y010	Coal Ash
Y021	Safety rest areas and scenic overlooks
Y022	Comfort and convenience facilities
Y023	Screening unsightly areas
Y024	Recreational facility
Y025	Fringe parking
Y026	Carpool facility (HOV)
Y028	Vanpool acquisition
Y030	Highway lighting
Y031	Traffic signals
Y032	Freeway traffic surveillance and control systems
Y033	Computerized traffic signal system
Y034	Motorist and system
Y035	Highway information
Y036	Computerized matching program
Y041	Special relocations (rivers, channels, etc.)
Y050	Frontage road
Y051	Independent Pedestrian Walkways
Y052	Independent Bicycle Facilities
Y060	Utility adjustment
Y070	Archeological salvage
Y071	Paleontological salvage
Y072	Historical, archeological or scientific site
Y080	Training (construction contracts)
Y081	Training (NHI)
Y102	Fencing
Y108	Transit passenger facilities
Y109	Truck loading facility
Y110	MCSAP (Development Code)
Y111	MCSAP (Enforcement Program)
Y112	CDL (Developmental)
Y113	CDL (Testing operators)
Y200	Bus purchases
Y205	Purchase of rolling stock (fixed rail)
Y210	Administrative expenses
Y215	Operating expenses (net)
Y219	Ferry boats
Y220	Noise abatement
Y222	Truck scales, fixed
Y223	Truck scales, portable
Y224	Auto restricted zone
Y225	Terminal and transfer facilities
CENG	Construction Engineering
GMKR	Geodetic markers
INSP	Bridge inventory, inspection and classification and other special bridge projects
MAIN	Maintenance
PCON	Post construction
PENG	Preliminary engineering
PE-1	Route planning, location studies (Appalachian funds only)
PE-2	Engineering design and construction plans (Appalachian)
PLAN	Planning (HPR, PR and PL funds)
RESH	Research (HPR, PR, and PL funds)
ROWA	Right-of-Way
R/WS	Acquisition of scenic strips outside of ROW
RW/O	Replacement Housing Payments – Owners
RW/T	Replacement Housing Payments – Tenants
R-MP	Residential Moving Payments
RW/B	Business and Farm Payments
R-SC	Relocation Services Costs
SFTY	Safety Related Work
UPLN	Urbanized Planning
YHOV	HOV Facility

1/ Y – Miscellaneous types first digit alpha. remaining digits numeric:
Beginning with "CENG" the "O" s are alpha

**FIGURE 2E-14 CONSTRUCTION TYPE CODE FOR HIGHWAY IMPROVEMENTS
LINE ITEM CODES**

INDEX OF SHEETS

An index showing each sheet number and description is typically shown on a separate plan sheet and assigned sheet number 1B. The index of sheets can be shown on the Title sheet when practical and the sheet numbers adjusted accordingly.

Sheet No. 1 is always assigned to the Title Sheet.

Sheet No. 1A is typically assigned to the Project Location Map , Sheet No. 1B is assigned to the Index of Sheets and Sheet 1C is usually assigned to the Right of Way Data Sheet. (Note: Numbering in the "1" series for Secondary projects must be adjusted to allow for exclusion of the Project Location Map).

Some plans are broken into smaller projects with two, three, or more projects using the same title sheet.

A proposed method for the index of sheets is shown in Figure 2E-15.

Sheet No. 1D is assigned to the Revision Data Sheet.

Sheet No. 1E is assigned to the Stream Flow Hydrograph Sheets, as provided by the Hydraulics Designer, when applicable.

Sheet Nos. 1F, 1G, etc., are assigned to the Alignment Data Sheet, when applicable.

Sheet No. 1H is assigned to the CADD Level Structure Sheet.

Sheet Nos. 1I, 1J etc., (picking up from the last applicable number) are assigned to Maintenance of Traffic and Sequence of Construction Sheets, where applicable.

Sheet No. 2 is assigned to the main Typical Section Sheet. General notes are to be shown on this sheet, if feasible, e.g. Secondary projects or other projects that do not require multiple typical sections.

Sheet Nos. 2A, 2B, etc., are assigned to other Typical Section Sheets, Detail Sheets, Summary Sheets and the Hydrologic Data Sheet, where applicable.

Sheet Nos. 3, 4, etc., are assigned to Plan Sheets.

Sheet Nos. 3A, 4A, etc., are assigned to Profile Sheets following each corresponding plan sheet.

Sheets which only pertain to Right of Way (i.e. R/W Data Sheet, Revision Data Sheet) are to be denoted with an asterisk as shown below:

SHEET NO. 1	TITLE SHEET
SHEET NO. 1A	PROJECT LOCATION MAP

SHEET NO. 1B	INDEX OF SHEETS
*SHEET NO. 1C	RIGHT OF WAY DATA SHEET
*SHEET NO. 1D	REVISION DATA SHEET
*SHEET NO. 1K	METES & BOUNDS

*Denotes sheets which are not to be printed for construction.

The sheet no. following the last profile sheet is assigned to **Sign** Plans, where applicable. All **sign** plan sheets are assigned one number with the total number of sheets afterwards in parentheses, such as: Sheet No. 8 (1 thru 10).

The next sheet number is assigned to Lighting Plans, similar to "**Sign** Plans".

Signal Plans are numbered next, similar to "**Sign** Plans".

The next sheet number is assigned to Utility Adjustment Plans, see IIM LD-140 where applicable, similar to above.

Bridge Plans will be assigned a Plan No. and Sheet No. by the Structures & Bridge Division. The bridge plans will follow the cross sections and listed as "Special Design Bridge Plan Sheets, "B" No., Plan No. (Number of Sheets)", followed by a brief description.

Any remaining sheets will follow, in order, those listed.

For Federal Projects, the [complete Federal Project Number\(s\)](#) is to be shown on all title sheets.

The total number of cross section sheets is shown below the last listed sheet.

The following notes are to be shown in the upper left portion of the Title Sheet:

For Index Sheets see Sheet 1B.

For IGrds Projects:

THIS PROJECT WAS DEVELOPED UTILIZING THE DEPARTMENT'S
INTERACTIVE GRAPHIC ROADWAY DESIGN SYSTEM (IGrds).
IGrds COMPUTER IDENTIFICATION NO. (PPMS NUMBER) _____.

For non IGrds Projects:

COMPUTER JOB NO. (DRD JOB NUMBER) _____.

NO. 1

NO. 2

NO. 3

NO. 4

NO. 5

NO. 6

NO. 7

NO. 8

NO. 9

INDEX OF SHEETS

DESIGN FEATURES RELATING TO CONSTRUCTION OR TO REGULATION AND CONTROL OF TRAFFIC MAY BE SUBJECT TO CHANGE AS DEEMED NECESSARY BY THE DEPARTMENT

BRIDGE	STATE	FEDERAL AID		STATE		TOTAL
		PROJECT	BRIDGE	PROJECT	BRIDGE	
	IL					18

- 1 TITLE SHEET
- 1A LOCATION MAP
- 1B INDEX OF SHEETS
- 1C RIGHT OF WAY DATA SHEET / DEMOLITION OF BUILDINGS / CLEARING OF PARCELS
- * 1D REVISION DATA SHEET
- 1E(1-3) SURVEY BASELINES DATA SHEETS AND BENCH MARK DESCRIPTIONS, SURVEY CONTROL SHEET
- 1F ALIGNMENT DATA
- 1G(1-7) SEQUENCE OF CONSTRUCTION
- 1H '95 CADD LEVEL STRUCTURE SHEET

- 2 GENERAL NOTES
- 2A(1-4) TYPICAL SECTION SHEETS
- 2B(1) GRADING DIAGRAM AND SUMMARY
- 2C(1-3) SUMMARY SHEETS
- 2D(1) DRAINAGE SUMMARY
- 2E(1-3) STORMWATER MANAGEMENT BASINS
- 2F(1-39) DETAILS AND INSERTABLE SHEETS
- 2G(1-5) APPROACH SLABS AND ABUTMENT BACKFILL DETAILS
- 2H(1) SPECIAL DESIGN DETAILS
- 2 I NOT INCLUDED
- 2J(1) DETAILS FOR TEMPORARY CAUSEWAY
- 2K(1) PERMANENT PAVEMENT MARKING AND SIGN LAYOUT

- 3 PLAN 1-BI NBL 20-00 TO 24-00
- 3A PLAN 1-BI SBL 20-00 TO 24-00
- 3B PROFILE 1-BI NBL AND SBL 20-00 TO 24-00
- 4 PLAN 1-BI NBL 24-00 TO 28-00
- 4A PLAN 1-BI SBL 24-00 TO 28-00
- 4B PROFILE 1-BI NBL AND SBL 24-00 TO 28-00
- 5 PLAN 1-BI NBL 28-00 TO 32-00
- 5A PLAN 1-BI SBL 28-00 TO 32-00
- 5B PROFILE 1-BI NBL AND SBL 28-00 TO 32-00
- 6 PLAN 1-BI NBL 32-00 TO 36-00
- 6A PLAN 1-BI SBL 32-00 TO 36-00
- 6B PROFILE 1-BI NBL AND SBL 32-00 TO 36-00
- 7 PLAN 1-BI NBL 36-00 TO 40-00
- 7A PLAN 1-BI SBL 36-00 TO 40-00
- 7B PROFILE 1-BI NBL AND SBL 36-00 TO 40-00
- 8 PLAN 1-BI NBL 40-00 TO 44-00
- 8A PLAN 1-BI SBL 40-00 TO 44-00
- 8B PROFILE 1-BI NBL AND SBL 40-00 TO 44-00
- 9 PLAN 1-BI NBL AND SBL 44-00 TO 48-00
- 9A PROFILE 1-BI NBL AND SBL 44-00 TO 48-00

- 105 CROSS SECTIONS

SPECIAL DESIGN BRIDGE B-601, PLAN NO. 284-69 (63 SHEETS)
1-BI NBL OVER BUFFALO CREEK

SPECIAL DESIGN BRIDGE B-602, PLAN NO. 284-70 (49 SHEETS)
1-BI SBL OVER BUFFALO CREEK

* NOT TO BE PRINTED FOR CONSTRUCTION



SUBMITTED BY: []
 DESIGNED BY: []

#FINESTAMP

FIGURE 2E-15 INDEX SHEET FOR MULTI-PROJECT PLANS

PROJECT LOCATION MAP (SEE FIGURE 2E - 16)

A project location map sheet is to be included on all projects other than Secondaries, and is to show sufficient surrounding area to provide obvious location of the proposed project.

Applicable project numbers (right of way and construction) are to be shown in the proper blocks and Supervisor's and Designer's name and phone number (including area code) are to be shown in the left border.

The project construction baseline is to be made conspicuous by use of a heavy line, dashed line, etc., so that it will stand out over other items on the sheet. Lines are to be extended (usually upward) from the ends of the project and expanded, if necessary, so that the project numbers can be shown along longitudinal lines similar to those on the Title Sheet.

Tie-in project numbers are to be shown on each end of the project, where applicable.

RIGHT OF WAY DATA SHEET (SEE FIGURE 2E - 17)

A Preliminary Right of Way Data Sheet is to be included in each applicable set of plans. These sheets are available from the Engineering Services Section's Insertable Sheet directory.

The "RW" project number is to be shown in the appropriate blocks (construction project numbers are not applicable to this sheet), and Supervisor's and Designer's names and phone numbers (including area code) are to be shown in the left border. No other information is necessary on the sheet at this time.

When the [field inspection plans are sent out](#), the set to the District Right of Way Manager shall include a blank print of this sheet. As the parcel numbers are assigned, the District Right of Way Office will tabulate the parcel numbers, landowners, proffers, and corresponding plan sheet numbers on the print and return it to the Central Office Right of Way Division with the plans that accompany the Field Inspection Report. (For further instructions on proffers, See IIM LD-189). On projects designed in the Central Office, this tabulation will then be forwarded to the Location and Design Division for inclusion in subsequent plan submissions. The tabulation will be furnished directly to the District Design Engineer on projects designed in the District Design Sections.

This sheet must be kept current by making the changes indicated by the Right of Way Division. Changes made subsequent to submission of approved Right of Way plans will be considered "[formal](#)" [revisions](#). The Preliminary Right of Way Data Sheet will be used from field inspection time until it is replaced by the Right of Way Division's "Posted Right of Way Data Sheet."

Right of Way Division's Building Data Report will be furnished to the Designer ninety days prior to advertisement. This report will confirm regular demolition numbers (D-1, D-2, etc.) as well as furnish special "D" series numbers for any underground storage tanks, "non-significant" signs or real personal property on the project (See page 2F-1, [PARCEL NUMBERS AND DEMOLITION NUMBERS ON PLANS](#)).

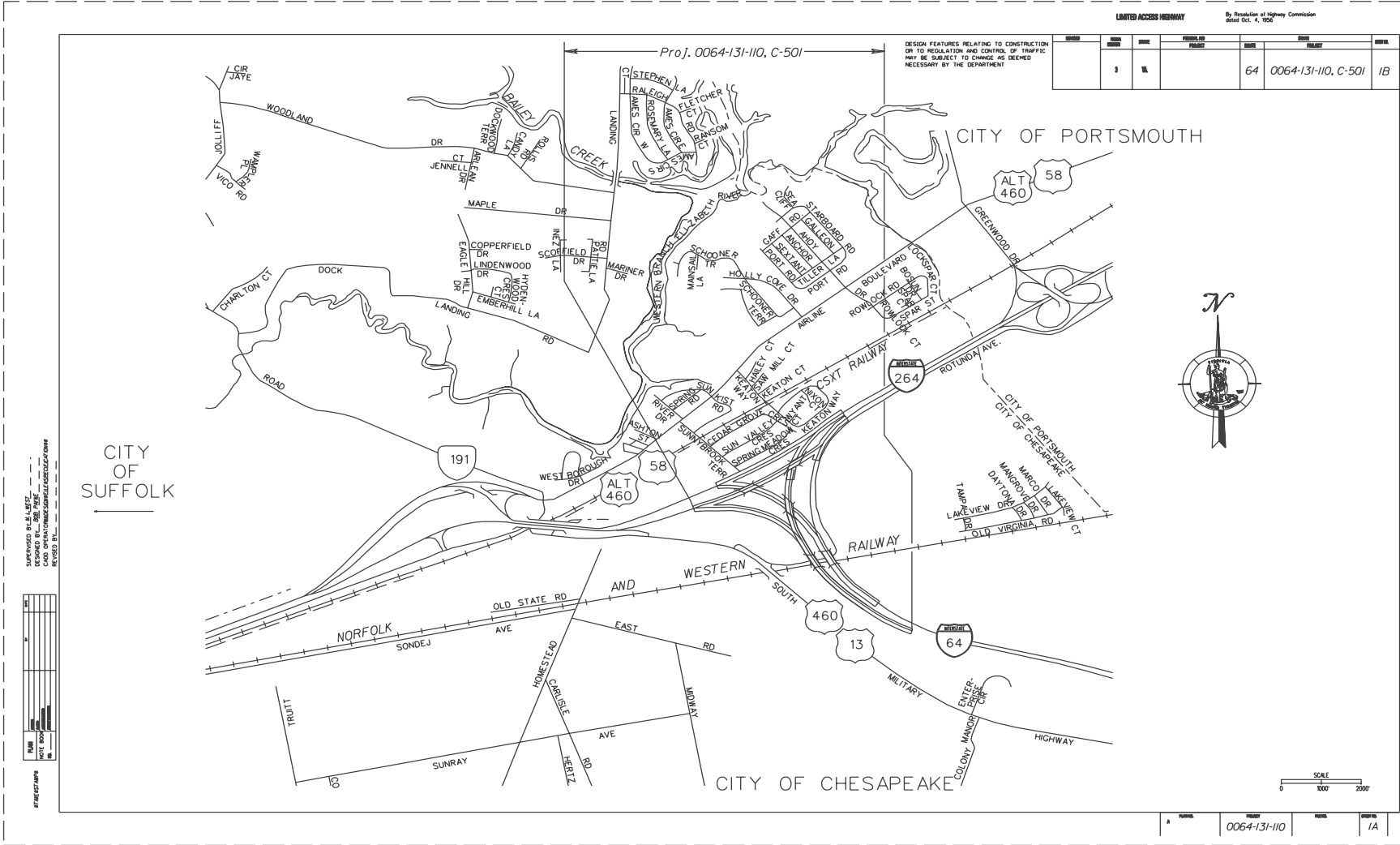

FIGURE 2E-16 SAMPLE PROJECT LOCATION MAP

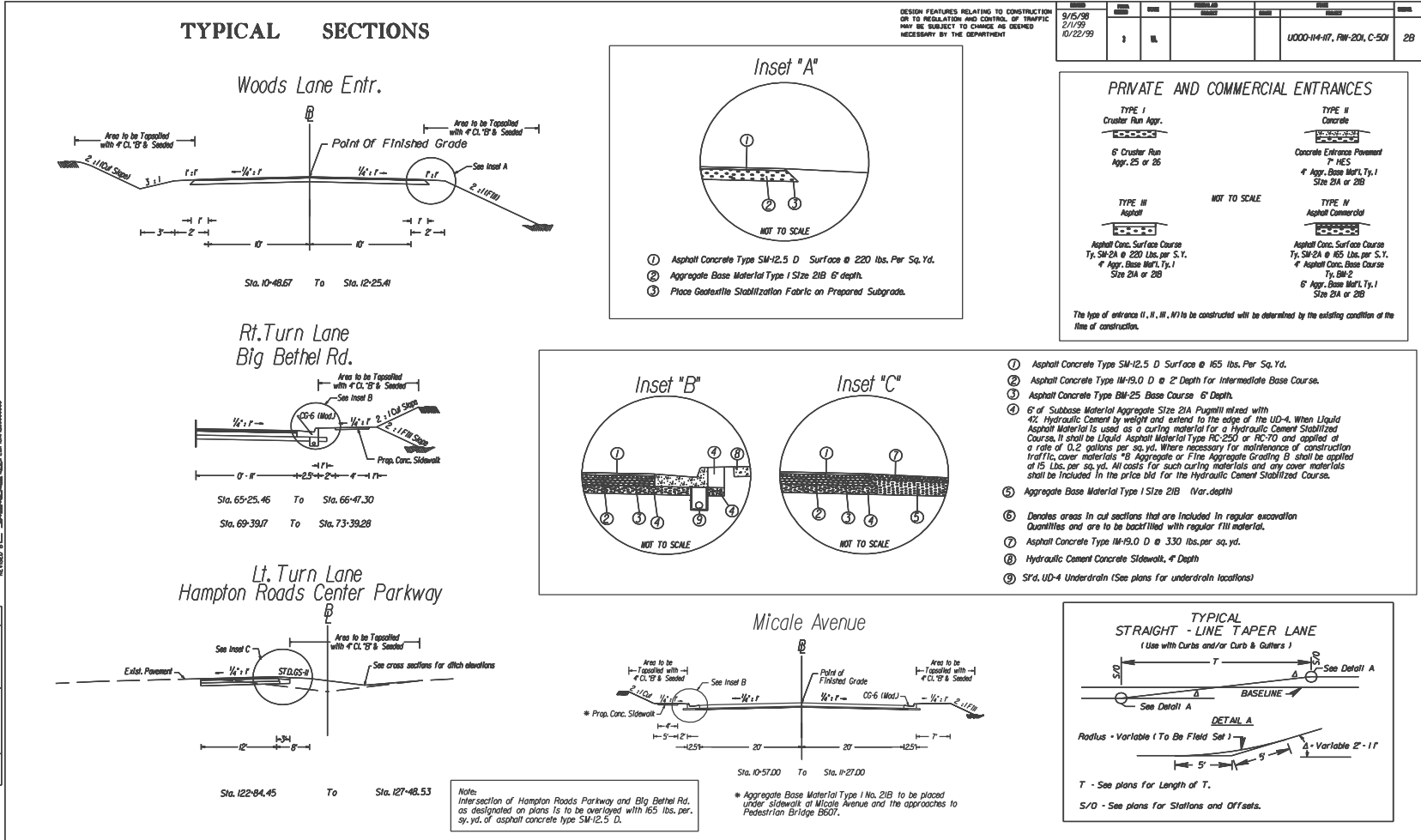

FIGURE 2E-18 SAMPLE TYPICAL SECTION SHEET

TYPICAL SECTION SHEET(S) (SEE FIGURE 2E - 18)

All applicable typical sections (mainline, connections, bikeways, ramps, frontage roads, etc.) are to be shown as a half section cut and half section fill, where applicable.

Applicable project numbers (right of way and construction) are to be shown in the proper blocks and Supervisor's and Designer's name and phone number (including area code) are to be shown in the left border.

The construction baseline is to be shown and labeled and the point of finished grade is to be clearly labeled with an arrow to the actual point.

If necessary (due to dual lanes, etc.), show existing roadway in dashed lines and label clearly. The existing baseline is to be depicted and labeled.

All slopes (pavement, shoulder, recoverable area, sidewalk space, side slopes, etc.) are to be shown immediately above the applicable line with arrows directed down grade to the slope. Pavement cross slopes for concrete and high type flexible pavement are to be 2%. Shoulder and ditch slopes are to conform to Design Guidelines (See [Appendix A](#)). Sidewalk or sidewalk space slopes are generally to be 2%. Side slopes, unless specifically recommended otherwise, are to conform to "CS" Standards for the particular roadway classification.

Dimensions are generally shown below the typical section with the first line showing dimensions of pavement, shoulder, recoverable area, ditch, curb and gutter, buffer strip, sidewalk space, etc., widths. The second line generally shows the roadway width.

Station to station for each typical section is to be shown beneath the dimension lines. The stations are to be broken for various projects and contracts.

Pavement courses are to be shown in accordance with the latest recommendations. If preliminary recommendations are used, this is to be brought to the attention of the field inspection party with the understanding that the pavement design will be updated accordingly once the soil survey and final pavement design recommendations have been received.

The depths of the various courses will be shown in an enlarged section, if necessary, to show detail.

Symbols are to be used to provide an obvious delineation of the courses. Pavement courses are to be shown in accordance with the CADD Manual.

Pavement courses, prime coats, incidentals, etc., are to be denoted with a number within a circle with a line to the denoted item. A legend is to be shown on each typical section sheet with complete descriptions of each item.

Ultimate sections are to be shown and clearly noted and delineated where applicable.

When placing and rolling flexible pavements, it is impossible to construct sides in a vertical plane without using forms. To make our drawings more realistic, show the side slopes at 1:1 as shown below. Do not denote the slope or the horizontal dimension (D) on the Typical Section. When computing quantities, no adjustment is to be made.

Projects without paved shoulders require a 0.3 m (1') wide "wedge" in accordance with IIM LD-158.

Typical Method of Grading Subsurface Material at High Side of Superelevated Curves with Shoulders Graded in Accordance with St'd. GS-11.

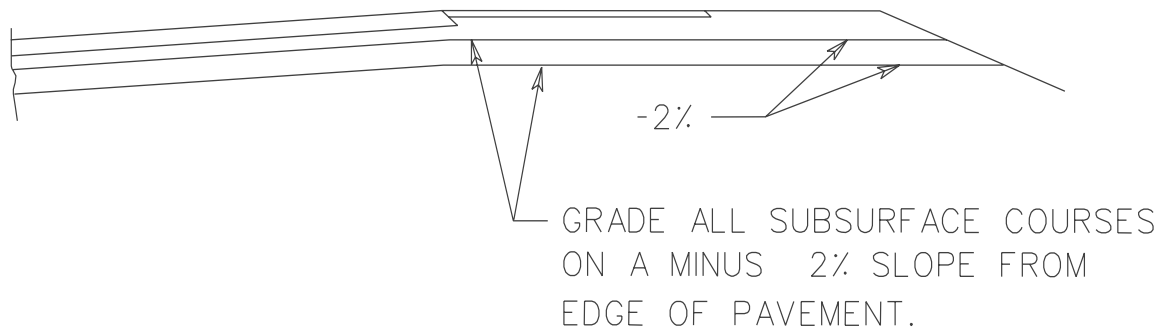

Bottom line of grading below pavement is to be parallel to pavement slope.

HYDROLOGIC DATA SHEET (SEE FIGURE 2E - 19 AND 2E - 20)

A Hydrologic Data Sheet is to be included in each applicable set of plans. The blank sheet is available in the Insertable Sheet directory. The drainage designer will furnish the project designer the data needed to fill in the Hydrologic Data Sheet at field inspection stage and again upon final completion of the drainage design. The project designer shall check with the drainage designer at this time to verify that the required water level information is shown on the profile sheets of the roadway plans.

DATE REVISION DATE REVISION DATE REVISION DATE REVISION DATE REVISION DATE REVISION DATE REVISION DATE REVISION

HYDROLOGIC DATA
 The data presented herein was statistically derived by empirical methods and from field observations. It is presented as an estimate of the hydraulic performance of these facilities during the passage of actual flood events.

1. Estimated 100 year frequency flood data (unless otherwise noted) This magnitude of flooding may pass through the proposed facility or it may obtain the necessary hydraulic conveyance by partial inundation of roadways and/or partial by pass of the facility.

2. Specified frequency flood data. It is anticipated that this magnitude of flooding will be conveyed through the proposed hydraulic facility under estimated conditions which satisfy the design criteria applicable to the site.

3. This data was obtained from observations by persons familiar with the area and/or of tidal records combined with an evaluation by empirical methods. The reliability of this data is relative to the accuracy of the source. A future flood of the same magnitude may achieve a significantly different stage elevation from that shown due to changes in the physical characteristics of the watershed.

DESIGN FEATURES RELATING TO CONSTRUCTION OR TO REGULATION AND CONTROL OF TRAFFIC MAY BE SUBJECT TO CHANGE AS DEEMED NECESSARY BY THE DEPARTMENT

DESIGN	DESIGN NUMBER	DATE	DESIGNER	CHECKED	PROJECT	SHEET
	1	11/1			U000-12-110, RW-201, C-501	21

FIELD INSPECTION STAGE <input type="checkbox"/>				FINAL DESIGN STAGE <input checked="" type="checkbox"/>				BASE FLOOD 1.				DESIGN FLOOD 2.				OVERTOPPING FLOOD 3.				HISTORICAL DATA			
Sheet No.	Station	Stream Name	Drainage Area	Structure Size	Discharge (C.F.S.)	Stage Elevation (F.T.)	Discharge (C.F.S.)	Estimated Exceedance Probability %	Stage Elevation (F.T.)	Discharge (C.F.S.)	Estimated Exceedance Probability %	Date	Stage Elevation (F.T.)	Estimated Exceedance Probability %	Remarks	Stage Elevation (F.T.)	Estimated Exceedance Probability %						
ID	57-55	Newmarket Creek	216 sq. mi.	49'	1367	22.0	746	ID	19.5	N/A	N/A	See Remarks											
REMARKS																							
Source of Information and Other Related Data																							
The historical high water mark and date shown on the bridge situation survey could not be substantiated. The calculated elevation for the ordinary high water discharge is higher than the high water mark for 1969. This historical high water mark should not be used. This crossing of Newmarket Creek is at a new location and therefore an accurate high water mark was not available.																							

SURVEYED BY _____
 DESIGNED BY _____
 DRAWN BY _____
 CHECKED BY _____
 DATE _____

9-19-1987
 SPECIAL DESIGN SECTION
 DRAWING NO. 2-A

DATE	PROJECT	DESIGN	SHEET
	U000-12-110		21

FIGURE 2E-19 SAMPLE HYDROLOGIC DATA SHEET

DESIGN FEATURES NOTE

A "[Design Features](#)" note is to be shown on all sheets, except cross sections:

DESIGN FEATURES RELATING TO CONSTRUCTION OR TO REGULATION AND CONTROL OF TRAFFIC MAY BE SUBJECT TO CHANGE AS DEEMED NECESSARY BY THE DEPARTMENT.

On the title sheet, the note is to be shown in the [lower left corner](#) as previously discussed in Section 2E-6 under "Notes".

On all other sheets, the note is to be shown to the left of the project identification block that is located in the upper right corner of the sheet. (See Figures 2E-18 and 2E-19).

SECTION 2E-7- CONSTRUCTION COST ESTIMATE

ESTIMATING QUANTITIES - PREPARATION OF ESTIMATE

Quantities for drainage (and minor structure excavation), pavement and incidental items as depicted on plans or work sheets, and total regular excavation and borrow or embankment quantities, along with estimated mobilization, clearing and grubbing, field offices, etc., are included in the project cost estimate.

When the estimate is received, a copy is to be sent to the Programming Division with the construction cost noted for field inspection stage. This applies to projects to be constructed with other than Urban or Secondary funds. For both Urban-funded projects and Secondary projects, a copy is to be sent to the Local Assistance Division. The estimate is to be entered into the P/PMS data bank.

A copy of the project cost estimate is kept in the appropriate file and the total cost is noted on the office copy of the field inspection prints for quotation at the inspection.

When not in use, cost estimates are to be placed in secure files and not left lying around for casual observation or possible copying by someone.

Cost Estimates made available outside of this division, such as to the Programming Division, the news media, etc., are the "total dollar cost" and are generally rounded off to the nearest thousand dollars. The construction cost estimate includes mobilization, construction engineering and contingencies.

The Project Manager reviews estimates (Preliminary Engineering and Construction) in PPMS at Scoping, Public Hearing, Field Inspection, Right of Way and Construction Stages, as well as at 90-day intervals between these milestones, for accuracy. If a project is significantly modified between these stages, the estimate must be adjusted and entered into PPMS and CES.

ALL Engineer's Estimates (Preliminary Engineering and Construction) will be reviewed by the Project Manager and updated, if necessary, for use by the Programming Division and Local Assistance Division in preparing the SYIP. At this time it is imperative that ALL estimates be reviewed for accuracy before incorporation into the new SYIP.

To obtain a cost estimate (total dollar cost), the freedom of Information Act requires written requests from persons outside the Department. The request is to be responded to within ten days of receipt.

Information indicating the specific unit cost for the various items in the estimate are to be retained by the project designer and secured when not being utilized. This information is available only through the Freedom of Information Act.

SECTION 2E-8- CONSTRUCTABILITY QUALITY REVIEW

CONSTRUCTABILITY QUALITY REVIEW

Constructability review is defined as the review of plans, specifications, and contract documents from a construction perspective to assure the documents propose an operation that is efficient, cost effective, and buildable. Its emphasis is primarily focused on “how” the documents propose the operation to be built and not on “what” gets built.

AASHTO defines constructability review as “a process that utilizes construction personnel with extensive construction knowledge early in the design stages of projects to ensure that the projects are buildable, while also being cost-effective, biddable, and maintainable”.

This analysis is normally performed at the Preliminary Field Inspection, Public Hearing, Field Inspection and Pre-Advertisement stage of plan development. Additional reviews can be performed as needed when the plans are further developed.

The constructability review includes the report of findings, a completed checklist, and cost savings report. This report is a detailed tabulation of any anticipated savings identified during the review. The Scheduling & Contract Division or its project team member will conduct the constructability review.

SECTION 2E – 9 - DISTRIBUTION OF FIELD INSPECTION PRINTS

PROCEDURE AND SCHEDULING

The [field inspection](#) is scheduled by the District Administrator who will arrange to have the plans reviewed, appropriate staff attend, and reports submitted by the appropriate divisions. A Project Engineer or Senior Inspector and a maintenance representative should be present to address project constructability and maintenance aspects and submit written reports.

Field inspections on urban projects will be scheduled by the Local Assistance Division in conjunction with the district office. A memorandum of confirmation is then sent to the Local Assistance Division. All appropriate parties will be advised by memorandum as to the time and location of the field inspection. Always advise the State Scheduling and Contract Division Engineer.

Copies of the applicable form (LD-99-I for rural projects, LD-99U for urban projects, or LD-103(SEC) for secondary projects) are attached to the field inspection prints and distributed in accordance with IIM LD-68. Form LD-99-I/(NV), LD-99-U(NV) or LD-103(NV)(SEC) are available for use on projects designed for the Northern Virginia District. Notice of the location and availability of prints should be furnished at least two weeks prior to the scheduled field inspection.

PLAN ASSEMBLY

The following is a general guideline of items to be included in the field inspection plan assembly and additional items may be required at times:

1. VDOT standard plan, profile and cross section sheets must be used (no rolls);
2. The [title sheet](#) should have a project layout with individual plan sheets indicated, a project description (must agree with PPMS description), the traffic data and functional classification block completely filled in, and a length tabulation for project numbers at bottom center;
3. Project [location map sheet](#) showing the project limits;
4. [Right of way data sheet](#) (blank);
5. Index of Sheets
6. Survey Data Sheet (horizontal survey alignment, reference data, bench marks);
7. Maintenance of traffic and sequence of construction sheets;

8. General Note Sheet with specific general notes for project;
9. Typical section sheets - mainline and all connections;
10. Underground utilities test hole information sheet;
11. Plan sheets (Nos. 3,4,5,6,7,etc.) must show:
 - a. Complete survey - topo, right-of-way, property lines, existing drainage elevations, invert elevations of existing sanitary manholes property owners, underground utilities, etc.;
 - b. Proposed horizontal alignment - bearings, curve data, superelevation, design speed;
 - c. Proposed right-of-way and easements - Pluses and distances; Show adequate right-of-way or permanent easements for all proposed permanent drainage items;
 - d. Proposed construction baseline, edge of pavements, medians, curbs, curb and gutter, sidewalk, construction limits, guardrail, etc.;
 - e. Proposed private entrances and tie-in points, grades are to be shown on profile sheets;
 - f. All required items should be labeled - St'd. CG-6 Req'd., St'd. MS-2 Req'd., St'd. CG-9D Req'd., St'd. RW-2 Req'd., etc.;
 - g. Required drainage - all pipes, drop inlets, end sections, etc., drawn to scale, complete drainage descriptions including elevations; Ditch typical sections should be shown for all nonstandard ditches;
 - h. Required erosion control items.
 - i. Tentative traffic control devices structures.
 - j. Tentative sound wall locations.
 - k. Tentative bridge design.
12. Profile sheet (Nos. 3A, 4A, 5A, 6A, 7A, etc.) must show:
 - a. Existing profile;
 - b. Proposed grades - gradient percents, vertical curves, vertical sight distances, design speeds;

- c. Proposed grades for all private entrances;
 - d. Drainage descriptions (required or existing) are not to be shown on profile sheets;
13. Cross sections with proposed design templates - mainline and connections;
Show all proposed ditches with grade elevations;
14. Completed computer estimate forms are needed at this time.

SECTION 2E – 10 - FIELD INSPECTION

HOLDING THE FIELD INSPECTION

The Field Inspection is presided over by the District Administrator or his/her representative, usually the District Construction Engineer.

A representative from the Design and Hydraulics Sections will attend every applicable field inspection with a set of prints reflecting all questions shown on the set supplied the District Administrator and any additional specific questions or comments necessary. The number of representatives is to be held to a minimum.

An experienced project inspector should be present to review a project for constructability and plan clarity. Also, someone should be in attendance who can address the maintenance aspects.

Review comments received prior to Field Inspection (e.g. Transportation & Mobility Planning, Traffic Engineering, Rail, etc.) are to be addressed at the Field Inspection or in a subsequent report.

All questions are to be completely legible and concisely answered on the office prints. The Location and Design representative is to return to the office with a complete understanding of all items discussed.

If an item is not addressed or a question not answered to the representative's satisfaction, it is his/her responsibility to make this known and to bring all items and questions to a satisfactory conclusion.

If any controversial item remains unresolved, the Location and Design Division representative, upon his/her return to the office, is to prepare a memorandum to the appropriate Assistant Location and Design Engineer and District Construction Engineer giving complete details of the situation.

All projects shall be reviewed on the site. All necessary safety equipment and precautions shall be utilized.

Reports from the District Materials, Traffic Engineering, Right of Way and Environmental Divisions, letters from municipalities, etc., are to be submitted to the District Administrator's representative, usually the District Location and Design Engineer. For projects managed in the Central Office the District Administrator/District Construction Engineer forwards the reports and a set of prints marked with comments to the State Location and Design Engineer within fourteen days in accordance with Form LD-99.

The Local Assistance Division submits a report on urban projects to the State Location and Design Engineer.

On consultant designed projects, the consultant shall prepare minutes of the Field Inspection and forward copies to individuals responsible for preparing reports.

The Project Manager will respond to the District Administrator or Urban Engineer outlining how plan development will proceed.

After the various Field Inspection reports are received, all necessary rulings on controversial questions are to be resolved and recommendations incorporated into the plans.

The Project Manager will respond to the Local Assistance Division Administrator for Urban Projects and the District Administrator or District Construction Engineer for all other projects with a resolution of all field inspection comments. Copies of this response which should include an explanation of reasons recommendations were not included in plans should be sent to all concerned.

SAFETY ITEMS AND SEQUENCE OF CONSTRUCTION

The safety of motorists, pedestrians, and construction workers during roadway construction must be carefully considered by the designer during the development of the road plans.

Safety during construction, sequence of construction, and maintenance of traffic are so closely related that they should be considered as one element.

"The Virginia Work Area Protection Manual" (See IIM LD- 93) is to be used as a reference to determine if barricades or channelizing devices need to be included in the contract plans.

In addition to determining the need for barricades and/or detours, the designer is to review the plans carefully for the possibility of shifting traffic lanes away from the normal position during construction. If this operation is necessary to construct the project, a sequence of construction is to be considered by the designer in conjunction with the appropriate Assistant Construction Engineers and/or appropriate Assistant District Engineer.

The Local Assistance Division, Asset Management Division, Structure and Bridge Division, and Traffic Engineering Division should be consulted on projects in their respective area of responsibility. The sequence of construction is to include diagrams and appropriate notes to inform the contractor as to how this operation is to be accomplished and advise of traffic problems that may be encountered. These shifts in

traffic flows are to be designed to conform to the geometrics shown in the standards for detours (St'd. GS-10) and/or as indicated in the "Safety Guidelines for Construction Zones" (See IIM LD- 93).

When a sequence of construction plan is considered necessary, it shall be included in the plans that are distributed for [review at the Field Inspection](#) and it shall be of sufficient detail to present the basic concept and to reflect environmental, traffic, safety, and right of way requirements.

A copy of the sequence of construction plan with the accepted Preliminary Field Inspection recommendations incorporated, is to be furnished to the Traffic Engineer prior to the public hearing/right of way stage. If detours and/or right of way (including easements) will be required for the maintenance of traffic, the sequence of construction must be completed in sufficient detail for the right of way requirements to be incorporated into the public hearing right of way plans.

Where a sequence of construction plan is considered unnecessary for a particular project, the file shall be documented accordingly with the listing of the names of those involved in the decision and the reasons for the decision.

The Field Inspection prints must also indicate that a sequence of construction plan is not necessary and that only such items as flagging, warning lights, etc., will be required.

All of the above items are to be discussed thoroughly at the Field Inspection and recommendations included in the Field Inspection Report.

REQUEST FOR SPECIAL DESIGN PLANS

After the Field Inspection questions have been resolved, requests shall be made to the [Standards/Special Design Section](#), by memorandum, to prepare the necessary special design roadway drawings for inclusion in the plans. This process is explained in Chapter 2G of this manual. The scheduled advertisement date, the project charge number, and prints of the pertinent plan sheets are to accompany the request. The designer is to furnish any required additional data and/or instructions to the Engineering Services Section to assure that correct specifications are incorporated in the drawing(s).

If circumstances dictate a change in the plans that would alter or eliminate the need for a special drawing that is in the process of being prepared, the Engineering Services Section is to be notified immediately.

The [Hydraulics Engineer](#) shall submit all requests for special design drainage items by

transmittal slip (copy to the Road Designer) to the Engineering Services Section. When the design is completed, the Engineering Services Section is to review the final design with the Hydraulics Section before furnishing the road designer with the drawing for insertion in the project assembly

REQUEST FOR SOUND BARRIER WALL DESIGNS

Sound Barrier Wall requirements for location and profile elevations are determined by the Environmental Division who will provide the roadway designer with the requirements. An explanation of this procedure is in Chapter 2G of this manual.

BRIDGES

When Field Inspections are held on projects involving new or existing bridges, particular attention must be paid to all discussions concerning these structures. The Structure and Bridge Division shall be notified of any decisions affecting a bridge design. A copy of the Field Inspection Report and any other applicable correspondence must be forwarded to them.

REQUEST FOR SPECIAL PROVISIONS

When a Project Manager is aware of the need for a Special Provision, the Project Manager will coordinate with the Scheduling and Contract Division as soon as possible.

If any doubt exists as to whether a given decision affects a bridge, the Structure and Bridge Division should be contacted informally and if a bridge is affected, a copy of the Field Inspection Report shall be sent them by memorandum explaining the facts.

SECTION 2E - 11 - REQUEST FOR ADDITIONAL SURVEY DATA

PROCEDURE FOR REQUEST

Necessary additional survey data is to be requested after the field inspection. A list of all additional survey needed is to be kept during plan development. Unless certain information is critical for plan development before this time, all items are to be held until one request for data can supply all information needed. Survey data is to be requested using Form LD-261.

The designer should check on site plan construction, and request additional survey for that portion of site plan affecting project design, when construction is completed or near completion.

SECTION 2E – 12- DISTRIBUTION OF PRINTS**PROCEDURE**

Whenever major changes occur as a result of the field inspection and/or Design or Combined Location and Design Public Hearing, such as interchange configuration, intersection design, etc., distribution is to be made in accordance with IIM LD- 68.

SECTION 2E-13 UTILITY FIELD INSPECTION

After field inspection recommendations have been resolved and incorporated into the plans, and the designer has evaluated any applicable test hole data (See IIM LD- 140) prints are to be submitted for Utility Field Inspection. Include the test hole data sheet and any available preliminary plans for bridges, retaining walls, traffic signals and lighting. (See IIM LD- 68)

The District Utility Engineer, or a representative, shall conduct the [Utility Field Inspection](#). On complex projects, the Designer may be requested to attend the Utility Field Inspection in order to provide an explanation of the design requirement. A Utility Field Inspection Report will be prepared with a copy to the Location and Design Engineer.

As soon as practicable after the Utility Field Inspection, the District Utility Engineer shall obtain replacement utility easement requirements from the affected utility companies. After review and approval of the utility easements, the District Utility Engineer shall transmit marked prints to the Transportation Engineer in charge of the project for addition to the Right of Way plans. The necessary utility easements shall be shown in accordance with Section 2E-5 -"UTILITY EASEMENTS".

The Utility Field Inspection Report will indicate which utility relocations will be placed in the highway contract. Usually a separate set of utility adjustment plans will be prepared and made a part of the project assembly. Screened reproducibles of the plan sheets and/or profiles are normally requested by the Utility Section for use in designing the utility adjustment plans.