

STP-2

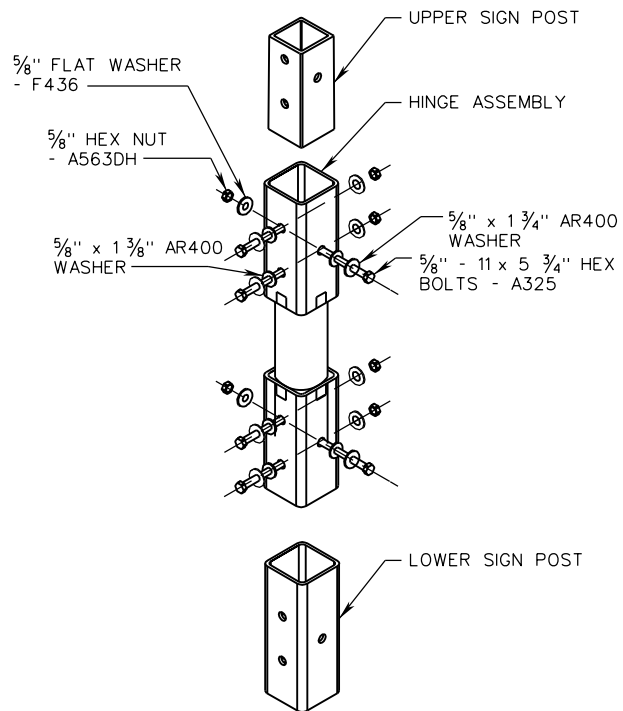

HINGE INSTALLATION DETAIL

NOTES:

1. HINGE ASSEMBLY SHALL BE USED FOR TWO AND THREE POST INSTALLATIONS ONLY.
2. HINGE ASSEMBLY BOLTS SHALL BE TORQUED TO 100 FT-LBS.
3. INSTALL PER MANUFACTURER'S INSTRUCTIONS.

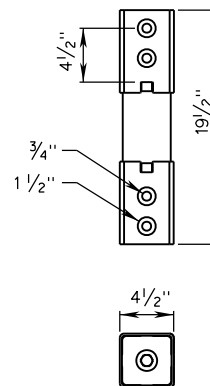

X4-HINGE ASSEMBLY

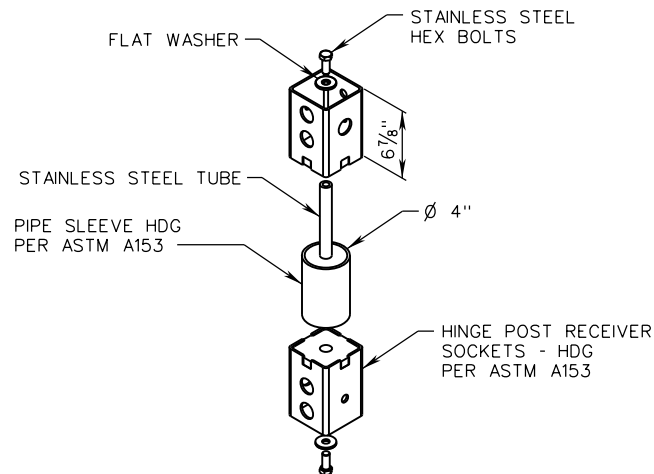

HINGE ASSEMBLY DETAIL

VDOT ROAD AND BRIDGE STANDARDS	
SHEET 4 OF 10	REVISION DATE NEW 09/18
1321.43	

A COPY OF THE ORIGINAL SEALED AND SIGNED DRAWING IS ON FILE IN THE CENTRAL OFFICE.
FOUR INCH SQUARE TUBE SIGN POST
HINGE ASSEMBLY DETAILS
 VIRGINIA DEPARTMENT OF TRANSPORTATION

SPECIFICATION REFERENCE
700