

SLIP BASE BREAKAWAY DETAIL

NOTES:

1. INSTALL PER MANUFACTURERS INSTRUCTIONS.
2. POST BOLTS SHALL BE TORQUED TO 100 FT-LBS.

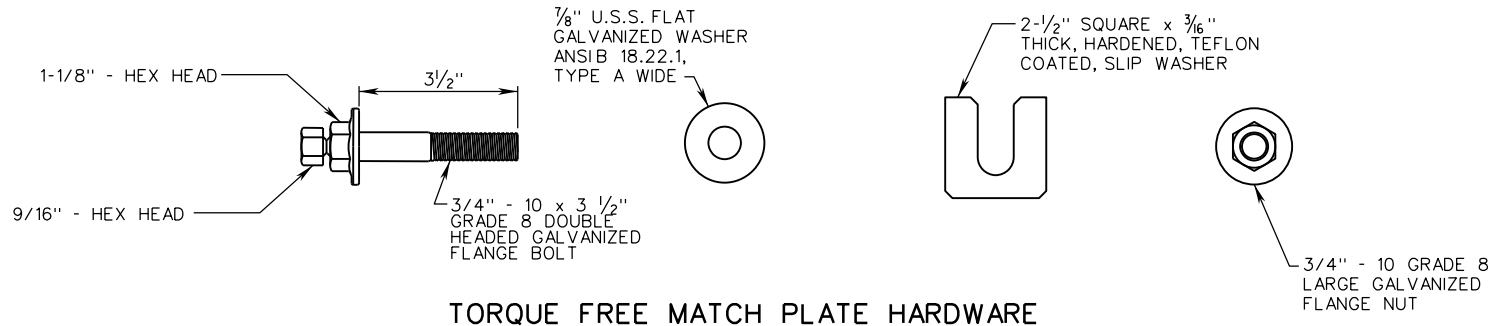

TORQUE FREE MATCH PLATE HARDWARE

SPECIFICATION REFERENCE
700

A COPY OF THE ORIGINAL SEALED AND SIGNED DRAWING IS ON FILE IN THE CENTRAL OFFICE.

FOUR INCH SQUARE TUBE SIGN POST
SLIP BASE DETAILS

VIRGINIA DEPARTMENT OF TRANSPORTATION

VDOT ROAD AND BRIDGE STANDARDS	
REVISION DATE	SHEET 3 OF 10
NEW 09/18	1321.42