

SINGLE

DOUBLE

MULTIPLE
(MAX. 4 BOXES)

24" MAXIMUM DEPTH (FOR METAL POSTS)

GROUPED

NOTES:

1. MAILBOXES SHALL BE OF LIGHT SHEET METAL OR PLASTIC CONSTR. CONFORMING TO THE REQUIREMENTS OF THE U.S. POSTAL SERVICE.
2. MAILBOX SUPPORTS SHALL NOT BE SET IN CONCRETE UNLESS THE SUPPORT DESIGN HAS BEEN SHOWN TO BE SAFE BY CRASH TESTS WHEN SO INSTALLED.
3. POSTS MAY BE 4" X 4" OR 4 1/2" DIAMETER WOOD POST, 2" DIAMETER STANDARD STRENGTH STEEL PIPE, OR OTHER STEEL OR ALUMINUM POST SHAPES OF EQUAL STRENGTHS.
4. THE POST-TO-BOX ATTACHMENT DETAILS SHOULD BE OF SUFFICIENT STRENGTH TO PREVENT THE BOX FROM SEPARATING FROM THE POST TOP IF THE INSTALLATION IS STRUCK BY A VEHICLE. HARDWARE SHOWN IS SUGGESTED ONLY, ALL GUIDELINES AS REQ'D. BY THE U.S. POSTAL SERVICE MUST BE FOLLOWED.

* DIMENSIONS VARY ACCORDING TO THE SIZE OF THE MAIL BOX.

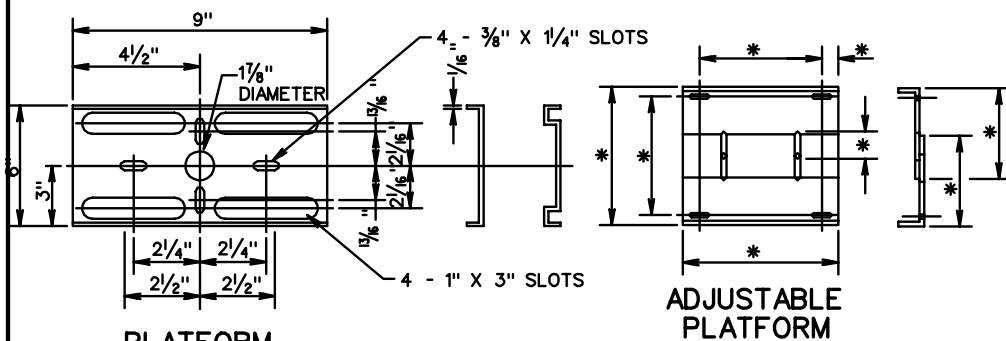

PLATFORM

ADJUSTABLE PLATFORM

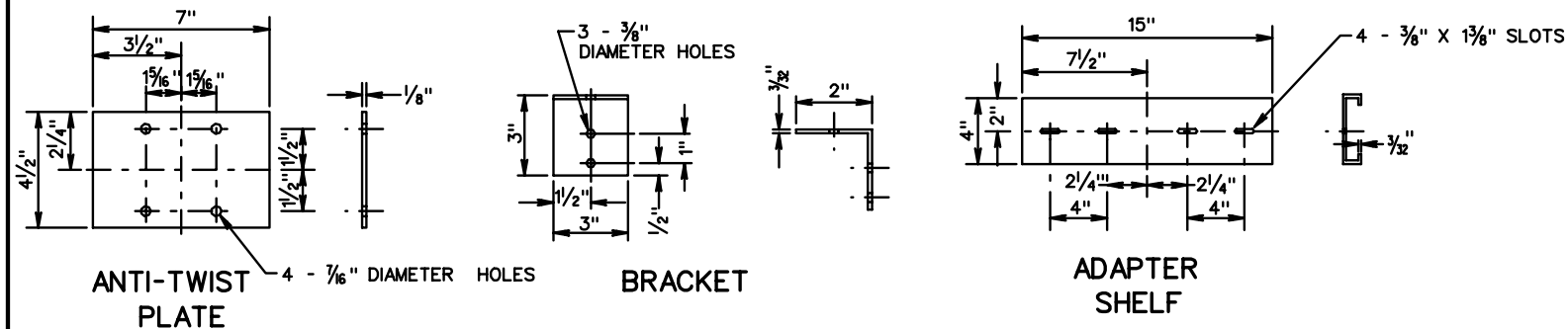

ANTI-TWIST PLATE

BRACKET

ADAPTER SHELF

| |
|-------------------------|
| SPECIFICATION REFERENCE |
| NONE |

STANDARD MAILBOX

VIRGINIA DEPARTMENT OF TRANSPORTATION



ROAD AND BRIDGE STANDARDS

REVISION DATE SHEET 1 OF 1

603.01