

MB-11A

STAKE LOCATIONS WHEN STAKING STANDARD MB-11A.
NOT TO BE USED ON BRIDGE DECKS.
4 PER PRECAST UNIT.
1 AT EACH CORNER.

STAKE LOCATIONS WHEN STAKING
STANDARD MB-11A.
NOT TO BE USED ON BRIDGE DECKS.
4 PER PRECAST UNIT.
1 AT EACH CORNER.

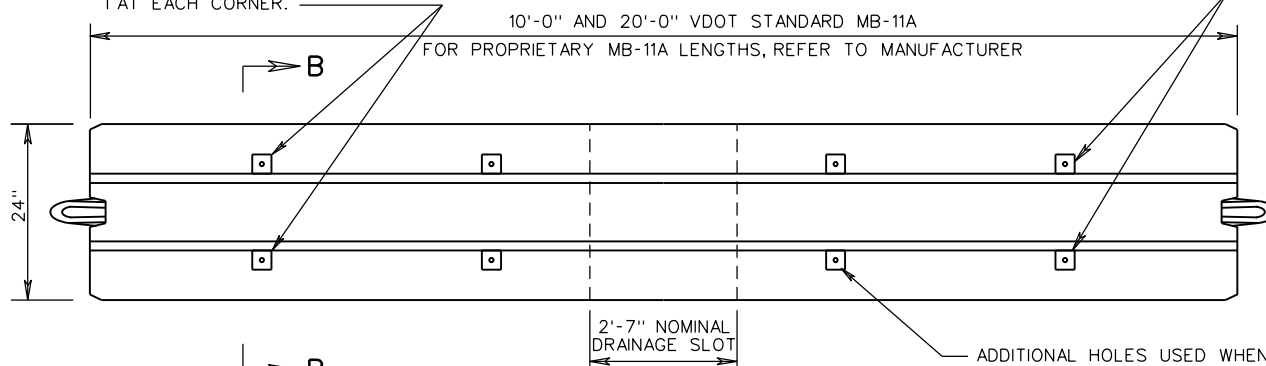

PLAN VIEW

FOR CONC. PAVEMENT
PRE-DRILL HOLES

ASPHALT CONC. PAVEMENT,
COMPACTED BASE MATERIAL,
CONCRETE PAVEMENT, OR
ASPHALT OVER CONCRETE PAVE.
1'-0" MIN. BEYOND EACH SIDE OF
BARRIER.

1" Ø X 24" GALV.
A36 STEEL STAKE.
4 PER PRECAST
UNIT. 1 AT EACH
CORNER. SEE
NOTE 3.

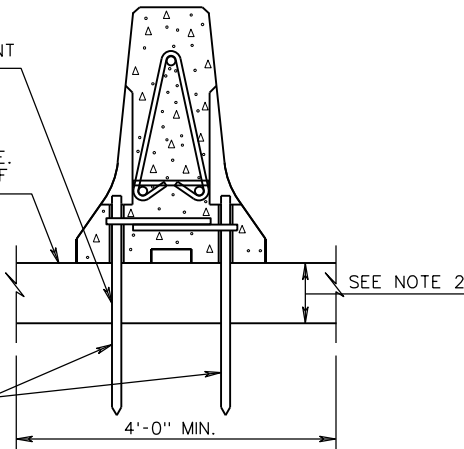

SECTION B-B

TEMPORARY INSTALLATION ON ASPHALT CONCRETE
PAVEMENT, COMPACTED BASE MATERIAL, CONCRETE
PAVEMENT, OR ASPHALT OVER CONCRETE PAVEMENT
(NOT TO BE USED ON BRIDGE DECKS)

NOTES:

1. STAKING OF STANDARD MB-11A TO ASPHALT CONCRETE PAVEMENT, COMPACTED BASE MATERIAL, CONCRETE PAVEMENT, OR ASPHALT OVER CONCRETE PAVEMENT IS REQUIRED WHEN TRAFFIC BARRIER SERVICE CONCRETE IS PLACED WITHIN THE TWO (2) FOOT OFFSET OF A TRENCHING OPERATION (4' OR GREATER IN DEPTH) OR WHEN DETERMINED BY THE ENGINEER.
2. 2" MIN. FOR ASPHALT CONCRETE.
6" MIN. FOR COMPACTED BASE MATERIAL.
3. DRIVE STAKE HEAD BELOW FACE OF BARRIER TO PREVENT SNAGGING.
4. CONTRACTOR TO VERIFY PAVEMENT STRUCTURE PRIOR TO PLACING STAKES.
5. UPON REMOVAL OF THE STAKES AND BARRIERS, REPAIR THE RESULTING HOLES AS FOLLOWS OR AS DIRECTED BY THE ENGINEER. CLEAN AND FILL WITH TYPE EP-4 OR EP-5 EPOXY MORTAR CONFORMING TO THE REQUIREMENTS OF SECTION 243 OF THE SPECIFICATIONS FOR HYDRAULIC CEMENT CONCRETE PAVEMENT AND ASPHALT CONCRETE PAVEMENT. CARE SHALL BE TAKEN NOT TO TRAP AIR WITHIN OR AT THE BOTTOM OF THE EPOXY MORTAR.



ROAD AND BRIDGE STANDARDS

SHEET 3 OF 3

REVISION DATE

502.15

01/09

TRAFFIC BARRIER SERVICE CONCRETE PARAPET
(DOUBLE FACE)

(FOR TEMPORARY INSTALLATION ON ROADWAYS)

VIRGINIA DEPARTMENT OF TRANSPORTATION

SPECIFICATION
REFERENCE

105
512