

MB-8A

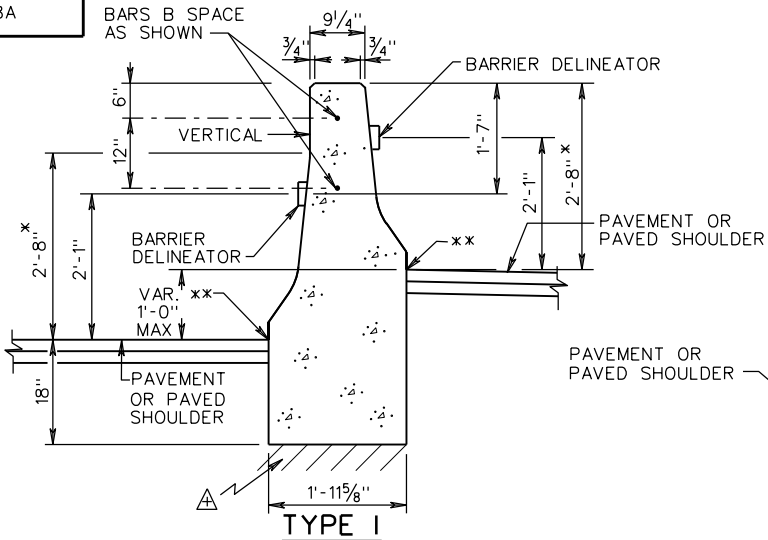

TYPE I (GREATER THAN 0 HT. DIFF., MAX. 1'-0")

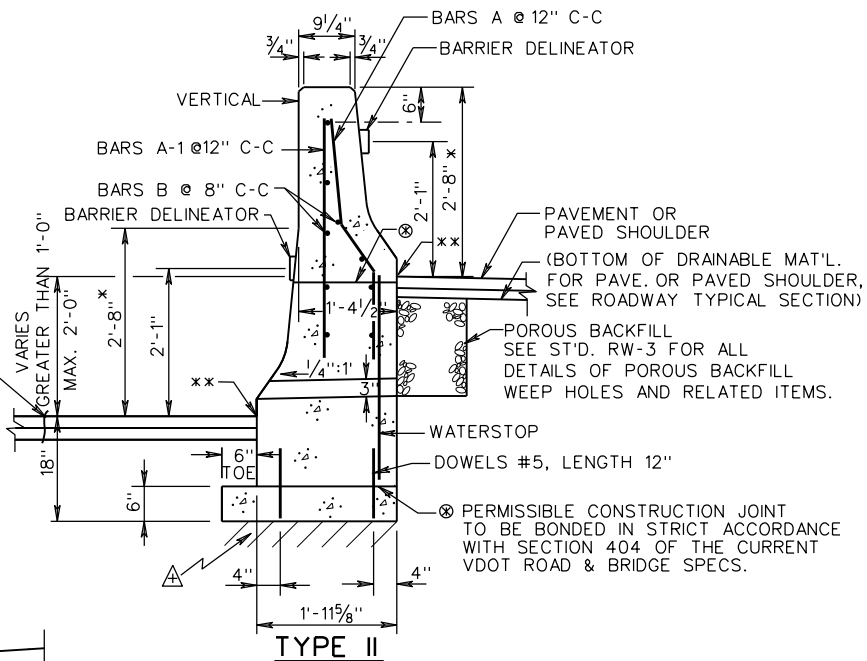

TYPE II (GREATER THAN 1'-0" HT. DIFF., MAX. 2'-0")

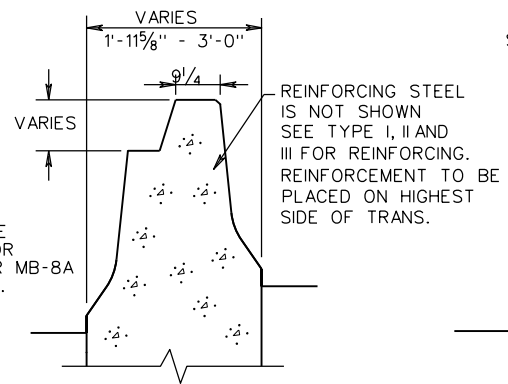
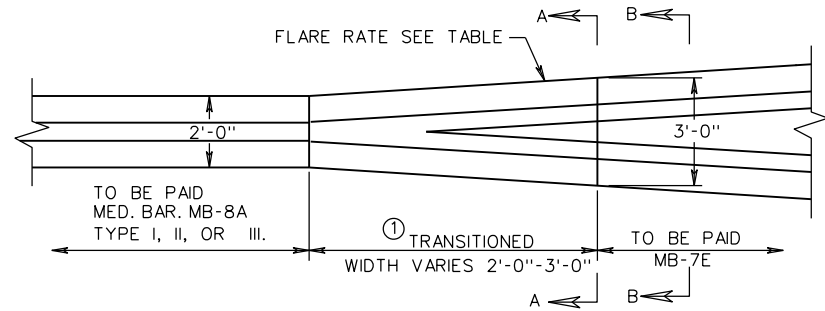

SECTION A-A (FOUNDATION NOT SHOWN)

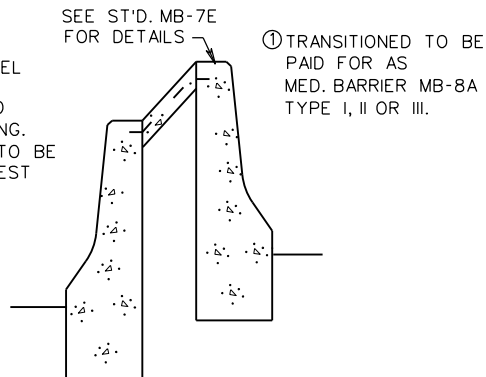

SECTION B-B (STD. MB-7E)

- \* MB-7D BARRIER FACE
- \*\* DENOTES FINISHED GRADE ELEVATION
- △ FOUNDATION MATERIAL UNDER MEDIAN BARRIER IS TO BE COMPACTED.

DESIGN SPEED	FLARE RATES	
	INSIDE SHY LINE	BEYOND SHY LINE
MPH	SHY LINE LS	FLARE RATE
70	10'	30 : 1 ②
60	8'	26 : 1 ②
50	6.5'	21 : 1 ②
40	5'	16 : 1 ②
30	3.5'	13 : 1 ②

② MAXIMUM FLARE RATE FOR RIGID BARRIER SYSTEMS.

VDOT ROAD AND BRIDGE STANDARDS  
SHEET 1 OF 2 REVISION DATE  
502.07

CONCRETE MEDIAN BARRIER  
TYPE I, II OR III  
VIRGINIA DEPARTMENT OF TRANSPORTATION

SPECIFICATION REFERENCE
105
404
502