

PLAN OF EXPANSION LIMIT

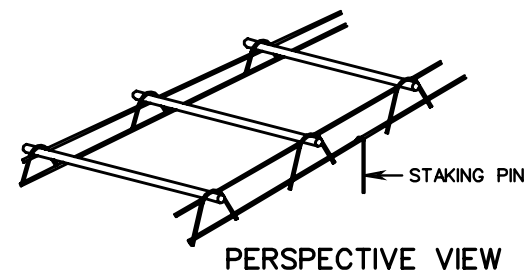

PERSPECTIVE VIEW

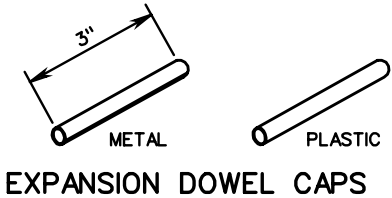

EXPANSION DOWEL CAPS

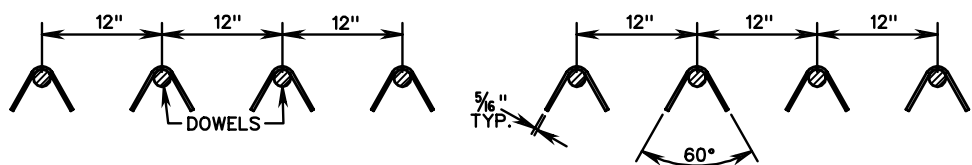

SECTION A - A CENTER FRAME

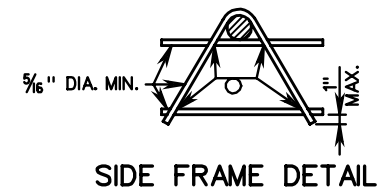

SIDE FRAME DETAIL

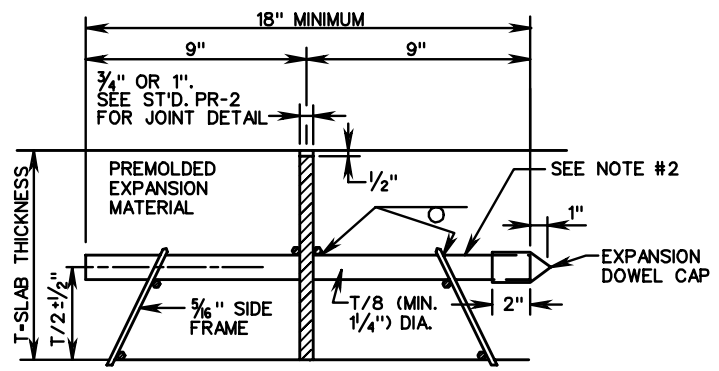

SECTION B - B THRU EXPANSION JOINT

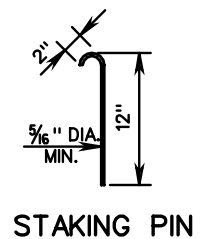

STAKING PIN

NOTES:

1. DOWEL BAR TO BE MIN. LENGTH OF 18". IF BAR IS NOT CENTERED THE LONG SIDE SHALL BE THE FREE END. SEE STANDARD PR-2.
2. ENTIRE BAR TO BE LUBRICATED.
3. STAKING PINS, A MINIMUM SIX PER ASSEMBLY, THREE TO EACH SIDE.
4. EXPANSION AND CONTRACTION JOINTS: THE DEVICE FOR SUPPORTING DOWELS AT EXPANSION AND CONTRACTION JOINTS SHALL BE SO CONSTRUCTED THAT IT WILL HOLD THE DOWELS FIRMLY IN POSITION, PARALLEL TO THE SURFACE AND CENTER-LINE OF THE SLAB.
5. NO MEMBERS SHALL BE PLACED SO THAT THEY WILL INTERFERE WITH THE FREE FLOW OF CONCRETE BETWEEN DOWELS.
6. ASSEMBLY AND WELDING OF ALL MEMBERS SHALL BE SUCH AS TO INSURE A GOOD WORKMANLIKE JOB, WITH ALL JOINTS TRUE AND SQUARE.
7. ASSEMBLIES WHICH HAVE BECOME WARPED OR DAMAGED IN TRANSIT OR STORAGE SO THEY WILL NOT CONFORM TO THE SUBGRADE SHALL NOT BE USED.
8. A SAMPLE OF THE SUPPORTING DEVICE SHALL BE SUBMITTED FOR APPROVAL PRIOR TO THE FILLING OF JOB ORDERS.

SPECIFICATION REFERENCE

STANDARD LOAD TRANSFER ASSEMBLY EXPANSION JOINT

VIRGINIA DEPARTMENT OF TRANSPORTATION



ROAD AND BRIDGE STANDARDS

REVISION DATE	SHEET 5 OF 5
	301.05