

SECTION
ENCASEMENT PIPE WITH CARRIER PIPE

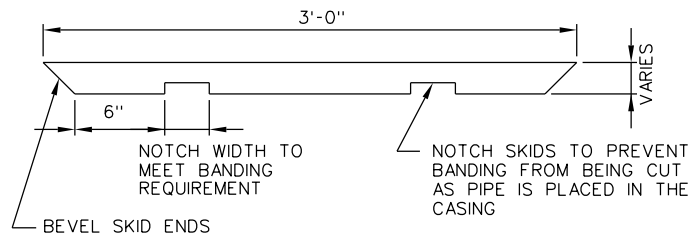

SKID

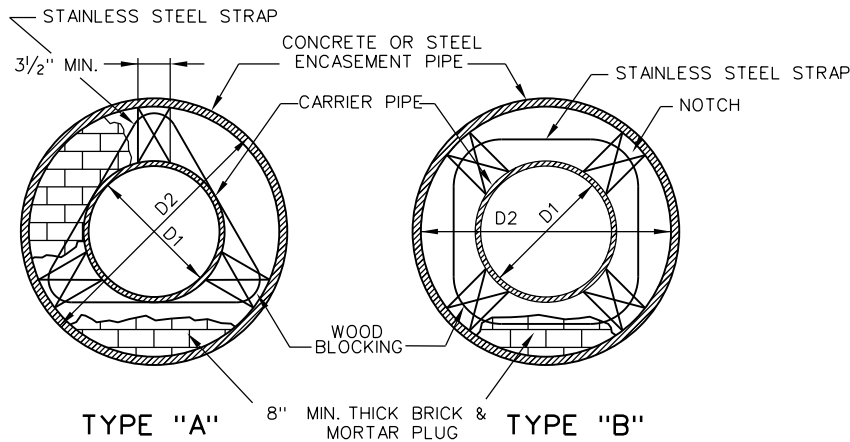

NOTES:

1. TIMBER SKIDS SHALL BE LOCUST, CYPRESS, PRESERVATIVE TREATED HARDWOOD, NEOPRENE, NYLON, PLASTIC OR OTHER MATERIAL OF HIGH ABRASION RESISTANCE AND A LOW FRICTION COEFFICIENT APPROVED BY THE ENGINEER. PRESERVATIVE FOR TIMBER SKIDS SHALL CONFORM TO SECTION 236 OF THE SPECIFICATIONS.
2. METAL STRAPS AND CLIPS HOLDING BLOCKING TO CARRIER PIPE SHALL BE STAINLESS STEEL WITH A MINIMUM CROSS SECTION OF 0.014 SQ. IN. STRAP SPACING SHALL BE A MINIMUM OF TWO (2) BANDS PER SKID LENGTH.
3. STEEL ENCASEMENT PIPE SHALL BE GRADE B AND SHALL CONFORM TO SECTION 232 OF THE SPECIFICATIONS OR AS SPECIFIED
4. CARRIER PIPE SHALL BE PUSHED OR PULLED THROUGH THE ENCASEMENT PIPE SO THAT JOINTS ARE ALWAYS BEING COMPRESSED.
5. CARRIER PIPE SHALL BE WRAPPED WITH TAR PAPER AT MASONRY PLUG.
6. MASONRY PLUG SHALL BE WATERTIGHT.
7. CONCRETE PIPE FOR H-20 LIVE LOAD AS PER STANDARD PC-1.
8. ENCASEMENT PIPE SHALL BE BEDDED IN ACCORDANCE WITH STANDARD PB-1.

SPECIFICATION REFERENCE

232
236

CONCRETE OR STEEL ENCASEMENT PIPE

VIRGINIA DEPARTMENT OF TRANSPORTATION

VDOT

ROAD AND BRIDGE STANDARDS

REVISION DATE

SHEET 1 OF 1

1404.01