

TYPE 1

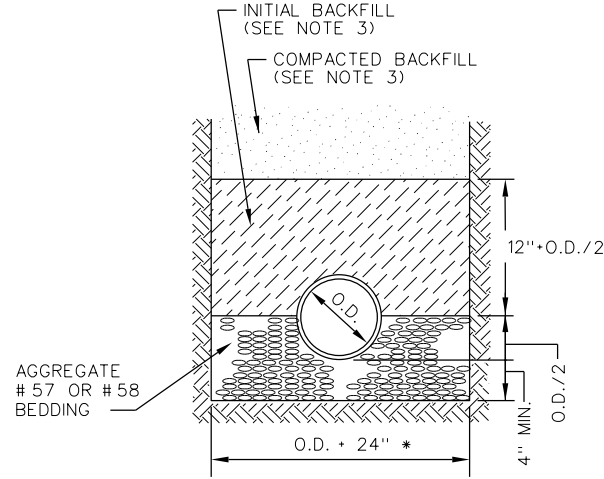

TYPE 2

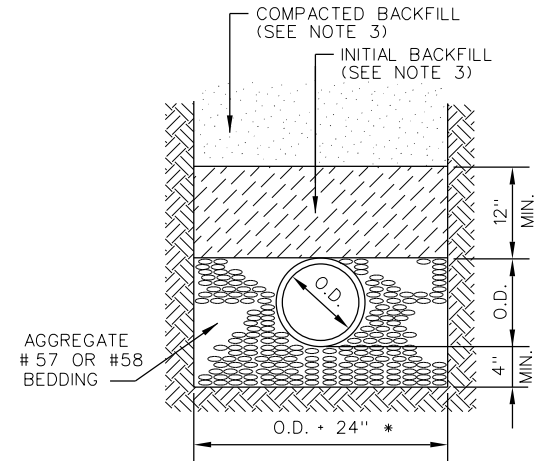

TYPE 3

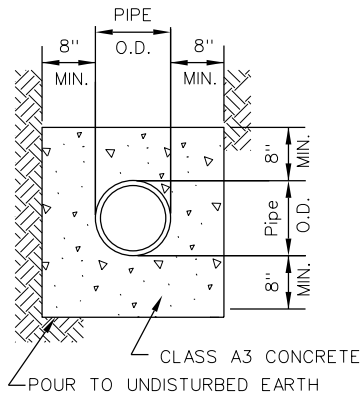

CONCRETE ENCASEMENT

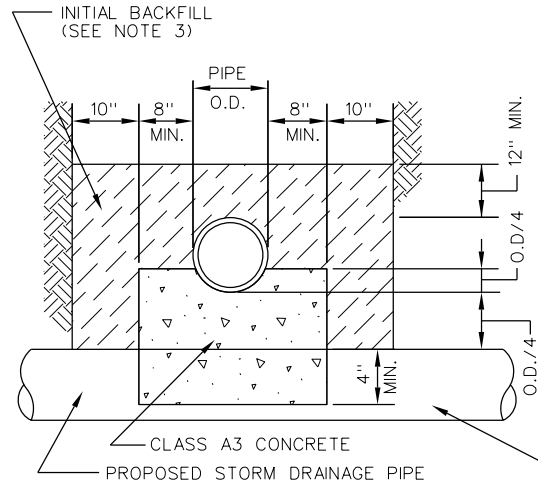

CONCRETE CRADLE

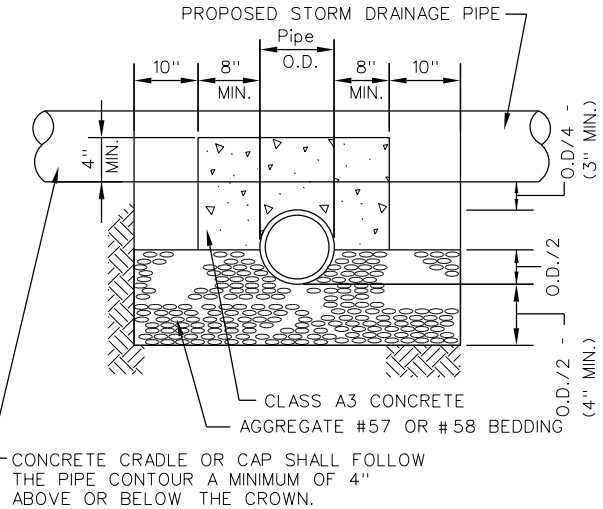

CONCRETE CAP

NOTES:

1. WHERE THE TRENCH BOTTOM IS IN ROCK, IT SHALL BE EXCAVATED TO A MINIMUM OF 8" BELOW THE BOTTOM OF THE PIPE BACKFILLED WITH BEDDING MATERIAL.
2. WHERE PIPE FOUNDATIONS ARE YIELDING, PIPE SHALL BE BEDDED ON A MINIMUM OF 8" BEDDING MATERIAL.

3. INITIAL AND COMPACTED BACKFILL SHALL MEET THE REQUIREMENTS OF SECTION 520 OF THE VDOT SPECIFICATIONS. CRUSHED GLASS CONFORMING TO THE SIZE REQUIREMENTS FOR CRUSHER RUN AGGREGATE SIZE 25 OR 26 AND MEETING THE REQUIREMENTS OF SECTION 520 OF THE VDOT SPECIFICATION MAY BE USED AS BACKFILL MATERIAL.

* FOR PIPE LESS THAN 12" THE TRENCH WIDTH MAY BE 36" MAXIMUM.

SPECIFICATION REFERENCE	<p>UTILITY BEDDING AND PROTECTION (WATER AND SANITARY SEWER FACILITIES)</p> <p>VIRGINIA DEPARTMENT OF TRANSPORTATION</p>	<p>ROAD AND BRIDGE STANDARDS</p>	<p>REVISION DATE</p>	<p>SHEET 1 OF 1</p>
520		<p>1401.01</p>		