

NOTES:

ALL CIRCUIT BREAKERS SHALL BE SINGLE POLE.

VOLTAGE AND AMPERAGE RATING OF CONTACTORS AND BREAKERS SHALL BE AS INDICATED ON THE PLANS.

NUMBER OF CIRCUITS SHOWN ARE TYPICAL. EXACT NUMBER REQUIRED SHALL BE AS INDICATED ON THE PLANS.

* CONTACTORS SHALL BE 2 POLES FOR SINGLE PHASE AND 3 POLES FOR THREE PHASE SERVICES. NUMBER OF CONTACTORS SHALL BE AS REQUIRED TO HANDLE THE NUMBER OF CIRCUITS ACTUALLY BEING UTILIZED.

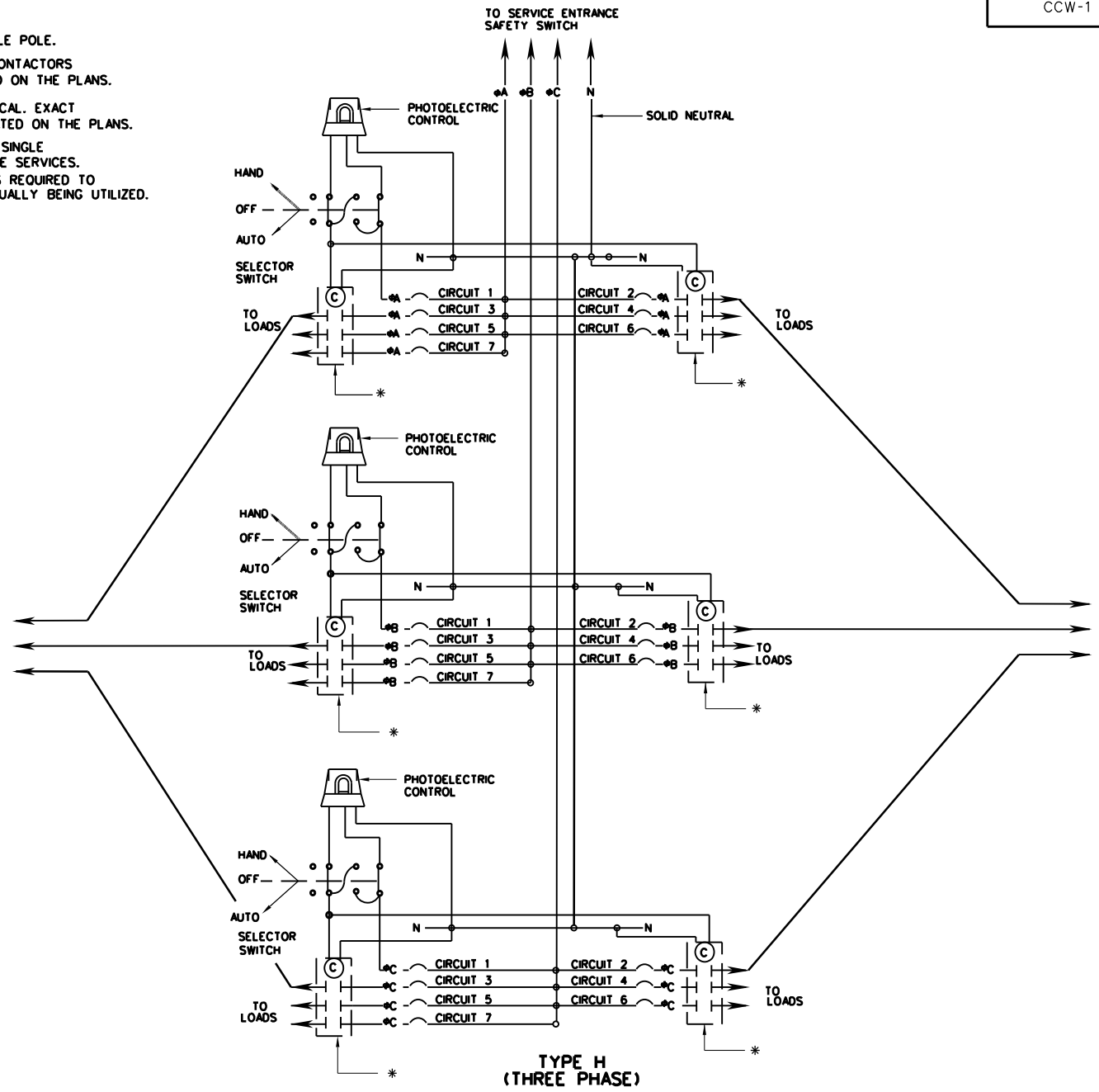

SPECIFICATION REFERENCE
700 705

CONTROL CENTER WIRING DETAILS

VIRGINIA DEPARTMENT OF TRANSPORTATION



ROAD AND BRIDGE STANDARDS

REVISION DATE SHEET 4 OF 4

1314.13