

MH-1

SEE STANDARD SL-1 FOR APPLICABILITY OF SAFETY SLABS.

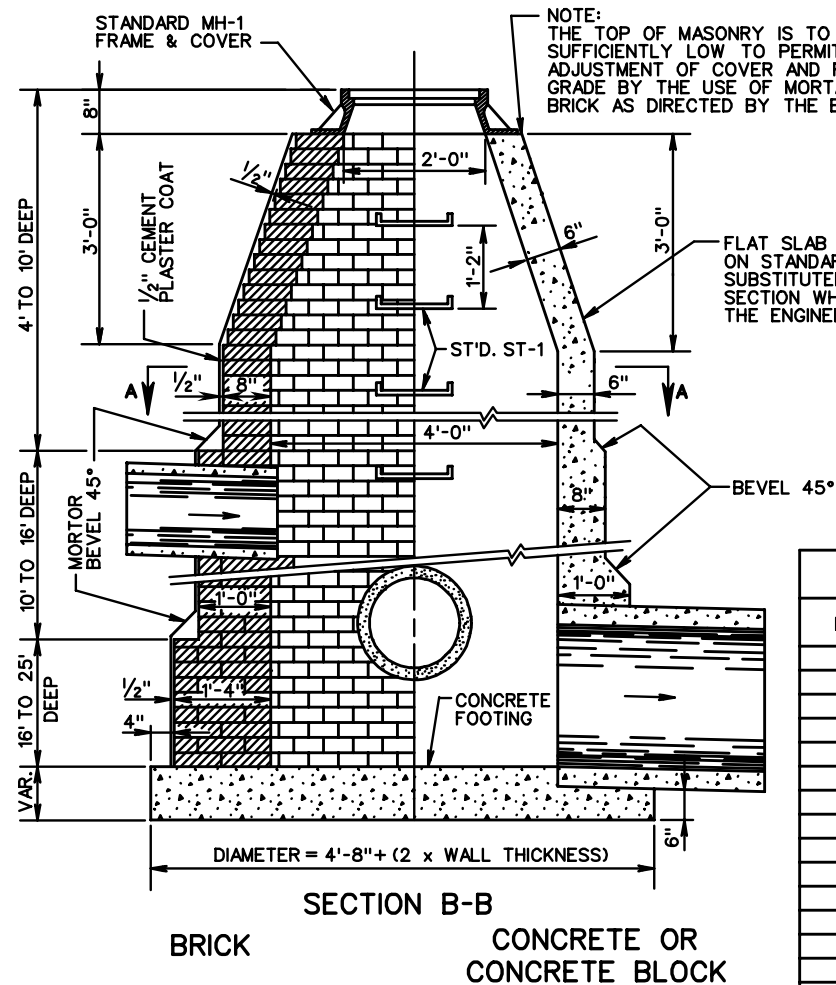

NOTE:
THE TOP OF MASONRY IS TO BE LEFT
SUFFICIENTLY LOW TO PERMIT PROPER
ADJUSTMENT OF COVER AND FRAME TO
GRADE BY THE USE OF MORTAR OR
BRICK AS DIRECTED BY THE ENGINEER.

FLAT SLAB TOP AS DETAILED
ON STANDARD T-MH-2 MAY BY
SUBSTITUTED FOR TAPERED
SECTION WHEN APPROVED BY
THE ENGINEER.

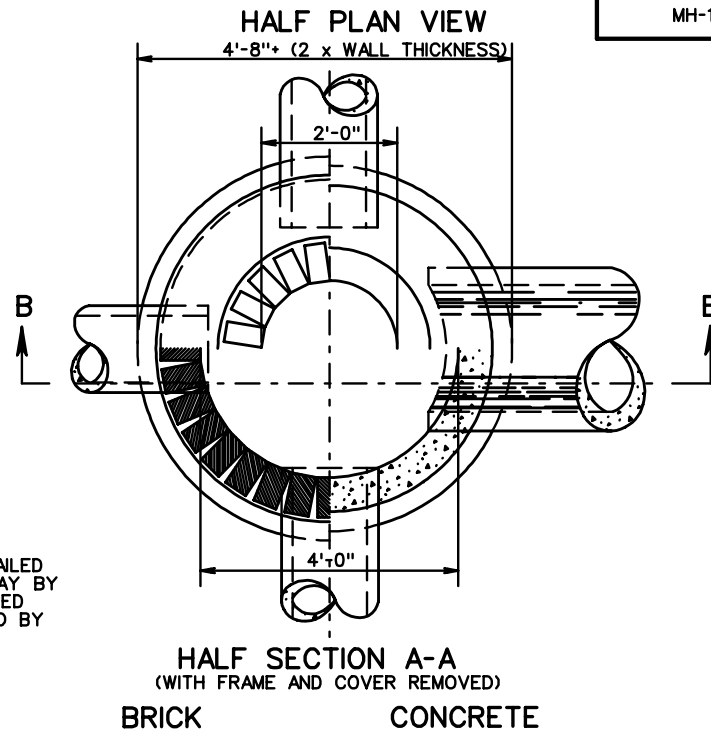

HALF SECTION A-A
(WITH FRAME AND COVER REMOVED)
BRICK CONCRETE

NOTES:

1. QUANTITIES SHOWN ARE FOR MANHOLE WITHOUT PIPES. THE AMOUNT DISPLACED BY PIPES MUST BE DEDUCTED TO OBTAIN TRUE QUANTITIES.
2. A BASE THICKNESS OF 9" WAS USED IN COMPUTING CONCRETE QUANTITIES.
3. INCREMENTS TO BE ADDED FOR EACH ADDITIONAL FOOT OF DEPTH.
4. MATERIALS MAY BE BRICK, CONCRETE OR APPROVED CONCRETE MANHOLE BLOCK.
5. IF BLOCKS ARE USED THE MINIMUM THICKNESS OF SAME IS TO BE 5". OTHER THICKNESSES ARE TO CONFORM TO WALL THICKNESS SHOWN FOR CONCRETE.
6. ALL CONCRETE TO BE CLASS A3.
7. WHEN SPECIFIED ON PLANS THE INVERT IS TO BE SHAPED IN ACCORDANCE WITH STANDARD IS-1. THE COST OF FURNISHING AND PLACING ALL MATERIALS INCIDENTAL TO THE SHAPING IS TO BE INCLUDED IN THE BID PRICE FOR THE STRUCTURE.

DEPTH	BRICK	MANHOLE	CONCRETE
FEET	BRICK	CONCRETE	CONCRETE
	THOUSANDS	CU. YARDS	CU. YARDS
4	0.5	0.785	1.437
5	0.7	0.785	1.699
6	0.9	0.785	1.961
7	1.0	0.785	2.223
8	1.2	0.785	2.485
9	1.4	0.785	2.747
10	1.6	0.785	3.009
11	1.9	0.970	3.455
12	2.2	0.970	3.817
13	2.5	0.970	4.179
14	2.8	0.970	4.541
15	3.1	0.970	4.903
16	3.4	0.970	5.265
17	4.0	1.173	6.032
INCREMENT	0.45	-	0.582

SPECIFICATION REFERENCE

302

MANHOLE FOR 12" - 48" PIPE CULVERTS

VIRGINIA DEPARTMENT OF TRANSPORTATION

VDOT

ROAD AND BRIDGE STANDARDS

REVISION DATE

SHEET 1 OF 5

106.01