

PI-1

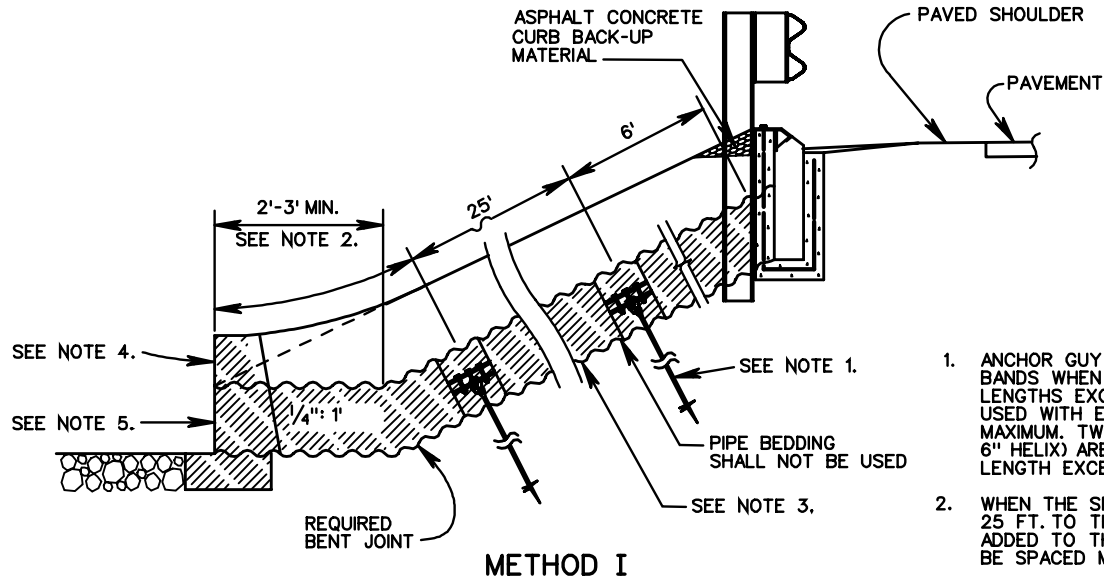

NOTES

1. ANCHOR GUY SCREWS ARE NOT TO BE USED WITH THE COUPLING BANDS WHEN THE PIPE LENGTHS ARE LESS THAN 50 FT. WHEN PIPE LENGTHS EXCEED 50 FT. TWO (2) ANCHOR GUY SCREWS ARE TO BE USED WITH EACH COUPLING BAND SPACED AT 25 FT. C-C MAXIMUM. TWO (2) ANCHOR GUY SCREWS, (1/2" DIAMETER X 5'-6", 6" HELIX) ARE TO BE USED WITH EACH COUPLING BAND, WHEN PIPE LENGTH EXCEEDS 50 FT.
2. WHEN THE SPACING OF THE LOWER COUPLING FALLS CLOSER THAN 25 FT. TO THE STORM SYSTEM STRUCTURE THE DISTANCE IS TO BE ADDED TO THE LAST FULL 12'-6" SPACE AND THE COUPLING IS TO BE SPACED MID-WAY OF THE TOTAL DISTANCE.
3. REQUIRED 15" CORRUGATED PIPE. SEE PLAN FOR LIN. FT. QUANTITIES. THE LIN. FT. COST FOR THE PIPE IS TO INCLUDE FURNISHING AND PLACING COUPLINGS AND ANCHOR GUYS. CORRUGATED POLY-ETHYLENE PIPE LENGTHS GREATER THAN 50 FT. MAY BE USED AS AN ALTERNATE PROVIDED THE COUPLING BAND ANCHORAGE DESIGN IS SUBMITTED BY THE MANUFACTURER FOR THE ENGINEER'S REVIEW AND APPROVAL.
4. REQUIRED 15" CORRUGATED PIPE MUST BE TERMINATED AT THE TOE OF FILL SLOPE WITH AN APPROPRIATE END TREATMENT. FOR 3:1 SLOPES AND FLATTER THE PIPE MAY BE TERMINATED WITH A STANDARD ES-2 END SECTION OR TIED INTO ANOTHER DRAINAGE STRUCTURE. FOR SLOPES 3:1 AND STEEPER (MAX. 1/2:1) THE 15" PIPE MUST HAVE ONE OF THE FOLLOWING END TREATMENTS (SEE PLANS FOR REQUIRED TYPE OF STRUCTURE):
 - METHOD I: TERMINATE PIPE WITH A STANDARD END WALL OR OTHER DRAINAGE STRUCTURE, TO BE APPROVED BY THE ENGINEER. FOR PIPE LENGTHS LONGER THAN 50 FT., COUPLING BANDS WITH ANCHOR GUYS ARE TO BE USED AT 12'-6" C-C MAXIMUM SPACING.
 - METHOD II: TERMINATE PIPE WITH A STANDARD ES-2 END SECTION ANCHORED WITH COUPLING BAND AND ANCHOR GUYS. ADDITIONAL COUPLING BANDS AND ANCHOR GUYS ARE TO BE PLACED AT 12'-6" C-C MAXIMUM FOR THE REMAINING LENGTH OF PIPE.
5. MORTAR REQUIRED CORRUGATED PIPE INTO THE WALL IF PRECAST STRUCTURE IS USED.

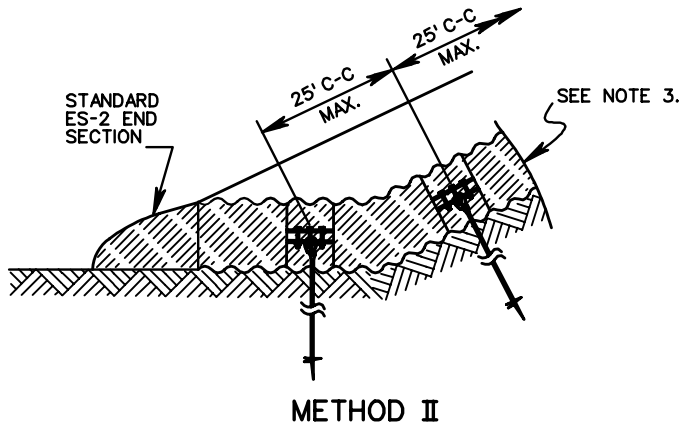

VDOT	
ROAD AND BRIDGE STANDARDS	
SHEET 1 OF 1	REVISION DATE
104.37	

METHOD OF OUTLET PIPE INSTALLATION FOR DI-13

VIRGINIA DEPARTMENT OF TRANSPORTATION

SPECIFICATION REFERENCE
232 302