

SECTION A-A

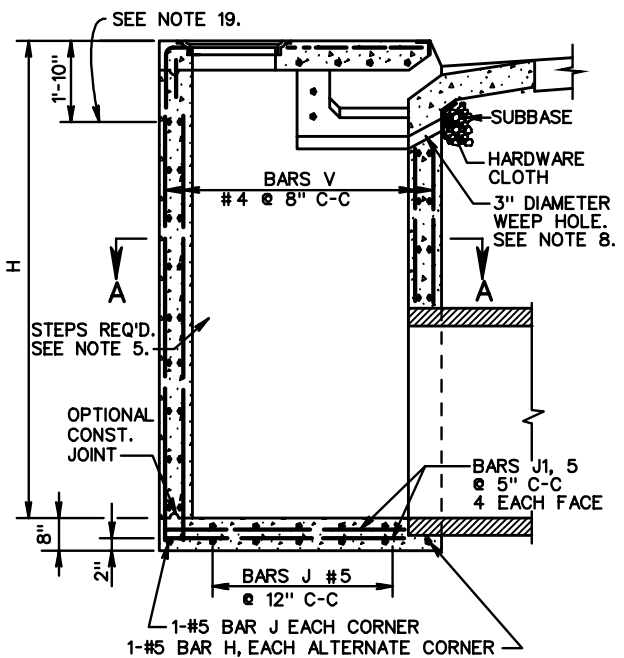

SECTION THROUGH ELEVATION

SCHEDULE OF REINFORCING STEEL SEE NOTE 17.					
BARS J		BARS J1		BARS V	
NO. REQUIRED	LENGTH	NO. REQUIRED	LENGTH	NO. REQUIRED	LENGTH
4X(H + 2)	5'-0"	4H+6	5'-6"	60	H-1'-4"

APPROXIMATE QUANTITIES FOR MINIMUM 8' DEPTH INLET			
TYPE	DIMENSION L SEE NOTE 18	REINFORCING STEEL	CONCRETE
	LIN. FT.	LBS.	CU. YDS.
4AA	4'-0"	798	5.14
4BB	6'-0"	856	5.56
4CC	8'-0"	914	5.97

NOTES

- DEPTH OF INLET (H) TO BE SHOWN ON PLANS. MINIMUM DEPTH (H) TO BE 8'-0". MAXIMUM DEPTH TO BE 20'-0". FOR INLETS LESS THAN 8' USE STANDARD DI-4A, 4B, AND 4C.
- THE "H" DIMENSION SHOWN ON THE STANDARDS AND SPECIFIED ON THE PLANS WILL BE MEASURED FROM THE INVERT OF THE OUTFALL PIPE TO THE TOP OF THE STRUCTURE. PLAN "H" DIMENSIONS ARE APPROXIMATE ONLY FOR ESTIMATING PURPOSES AND THE ACTUAL DIMENSIONS SHALL BE DETERMINED BY THE CONTRACTOR FROM FIELD CONDITIONS.
- WHEN SPECIFIED ON THE PLANS THE INVERT IS TO BE SHAPED IN ACCORDANCE WITH STANDARD IS-1. THE COST OF FURNISHING AND PLACING ALL MATERIALS INCIDENTAL TO THE SHAPING IS TO BE INCLUDED IN THE BID PRICE FOR THE STRUCTURE.
- IN THE EVENT THE INVERT OF THE OUTFALL PIPE IS HIGHER THAN THE BOTTOM OF THE STRUCTURE, THE INVERT OF THE STRUCTURE SHALL BE SHAPED WITH CEMENT MORTAR TO PREVENT STANDING OR PONDING OF WATER IN THE STRUCTURE. THE COST OF FURNISHING AND PLACING ALL MATERIALS INCIDENTAL TO THE SHAPING IS TO BE INCLUDED IN THE BID PRICE FOR THE STRUCTURE.
- STEPS ARE TO BE PROVIDED. FOR DETAILS SEE STANDARD ST-1.
- THIS ITEM MAY BE PRECAST OR CAST-IN-PLACE.
- #4 X 8" SMOOTH DOWELS AT APPROXIMATELY 12" C-C TO BE PLACED IN ALL AREAS ADJACENT TO ABUTTING CONCRETE TO PREVENT SETTLEMENT. IN LIEU OF DOWELS A 2" X 4" NOTCH MAY BE PROVIDED. SEE STANDARD T-DI-3, 4 FOR ALTERNATE DESIGN.
- 3" DIAMETER WEEP HOLE TO BE LOCATED TO DRAIN SUBBASE MATERIAL. WEEP HOLE WITH 12"X12" PLASTIC HARDWARE CLOTH 1/4" MESH OR GALVANIZED STEEL WIRE, MINIMUM WIRE DIAMETER 0.03", NUMBER 4 MESH HARDWARE CLOTH ANCHORED FIRMLY TO THE OUTSIDE OF THE STRUCTURE.
- ALL REINFORCING STEEL SHALL HAVE A MIN. COVER OF 2".
- ALL REINFORCING STEEL TO BE CUT CLEAR OF ALL OPENINGS BY 2".
- CAST-IN PLACE CONCRETE IS TO BE CLASS A3 (3000 PSI). PRECAST CONCRETE IS TO BE 4000 PSI.
- LENGTH OF SLOT (L) WILL, IN EVERY CASE, BE SHOWN ON PLANS.
- IF INLET IS CONSTRUCTED IN MEDIAN CURB OR WITH INTEGRAL CURB, GUTTER IS TO BE OMITTED (SEE DETAIL WITH STANDARD DI-4A, 4B, 4C).
- IF OPTIONAL CONSTRUCTION JOINT IS USED IT IS TO BE KEYPED. ALL SPLICES IN BARS V TO BE A MINIMUM OF 40 DIAMETERS (20").
- FOR PLAN VIEW OF INLET SEE STANDARD DI-4A, 4B, 4C.
- QUANTITIES SHOWN ARE FOR MINIMUM INLETS OF EACH TYPE. FOR INLETS OF GREATER DEPTH (H) OR LONGER SLOT (L) INCREMENTS SHOWN PER FOOT MUST BE ADDED. THE AMOUNT OF CONCRETE AND STEEL DISPLACED BY PIPES MUST BE DEDUCTED TO OBTAIN TRUE QUANTITIES.
- FOR NUMBER OF BARS A-H REQUIRED AND LENGTH SEE TABLE OF QUANTITIES FOR STANDARD DI-4A, 4B, 4C.
- FOR DESCRIPTION AND LOCATION OF DIMENSION L SEE SHEET STANDARD DI-4A, 4B, 4C.
- FOR ALL DETAILS, DIMENSIONS AND REINFORCING STEEL ABOVE THIS LINE, SEE STANDARD DI-4A, 4B, AND 4C.
- PROVIDE SAFETY SLABS WHEN SPECIFIED ON THE PLANS.

INCREMENTS TO BE ADDED FOR EACH ADDITIONAL FOOT OF DEPTH (H) AND/OR SLOT LENGTH (L)			
H		L	
CONCRETE CU. YDS.	STEEL LBS.	CONCRETE CU. YDS.	STEEL LBS.
0.479	84	-	-
0.479	84	0.22	23.5
0.479	84	0.22	23.5

VDOT
ROAD AND BRIDGE STANDARDS

SHEET 1 OF 1
104.17

REVISION DATE

STANDARD CURB DROP INLET
36" - 48" PIPE: DEPTH (H) 8' TO 20'
VIRGINIA DEPARTMENT OF TRANSPORTATION

SPECIFICATION
REFERENCE

233
302