

EW-9

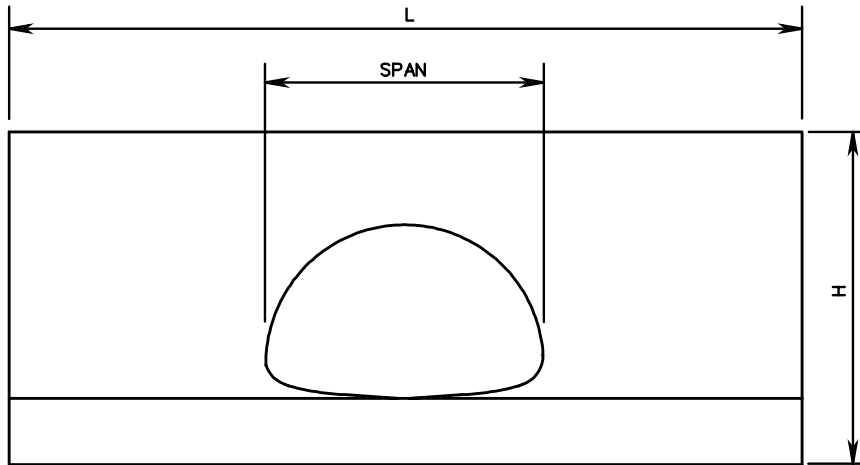

FRONT ELEVATION

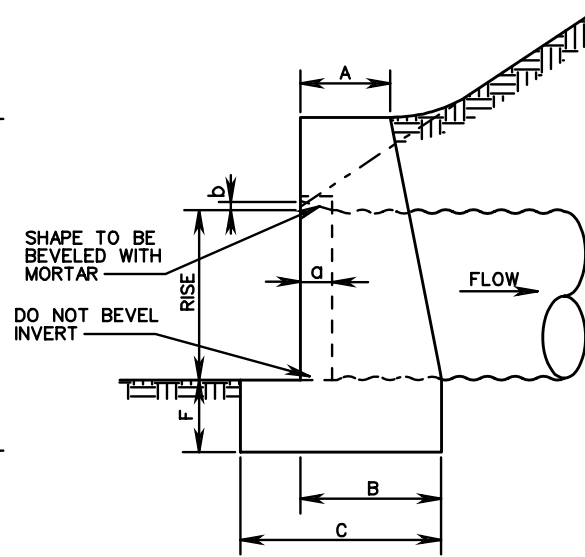

SIDE ELEVATION

NOTES:

1. THIS ITEM MAY BE PRECAST OR CAST IN PLACE.
2. ON SHALLOW FILLS, WHERE ENDWALLS ARE 1' OR LESS BELOW SHOULDER LINE, THE TOP OF THE ENDWALL SHALL BE CONSTRUCTED PARALLEL TO THE GRADE OF ROAD.
3. ALL CAST IN PLACE CONCRETE TO BE CLASS A3. FOR PRECAST SEE SHEET 101.23.
4. IN NO CASE SHALL TOP OF ENDWALL PROJECT ABOVE FILL SLOPE, DITCH SLOPE, OR SHOULDER.
5. HEADWALL TO BE BEVELED IN ALL AREAS EXCEPT WHERE A CONFLICT WITH INVERT AND WINGWALLS OCCUR.
6. BEVEL EDGE IS REQUIRED ON THE HEADWALL AT THE INLET END OF THE CULVERT (WHERE THE FLOW ENTERS THE CULVERT). HEADWALL AT THE OUTLET END OF THE CULVERT MAY BE EITHER SQUARE EDGE OR BEVEL EDGE.
7. 3/4" CHAMFER MAY BE PROVIDED ON ALL EDGES AT MANUFACTURER'S OPTION.

CORRUGATED METAL PIPE										
NOMINAL DIMENSIONS OF PIPE ARCH		DIMENSIONS FOR ONE SINGLE ENDWALL						CUBIC YARDS CONCRETE FOR ONE ENDWALL	a	b
SPAN	RISE	A	B	C	F	H	L			
17"	13"	0'-6"	0'-11"	1'-4"	0'-6"	2'-2"	4'-3"	0.258	0'-2"	0'-1/4"
21"	15"	0'-6"	0'-11"	1'-4"	0'-6"	2'-4"	5'-1"	0.322	0'-2 1/2"	0'-1 1/2"
24"	18"	0'-8"	1'-1 1/2"	1'-7"	0'-8"	3'-0"	6'-1"	0.626	0'-3"	0'-2"
28"	20"	0'-9"	1'-3"	1'-9"	0'-8"	3'-2"	6'-11"	0.823	0'-3"	0'-2"
35"	24"	0'-11"	1'-6"	2'-2"	0'-9"	3'-7"	8'-6"	1.371	0'-4"	0'-2 1/2"
42"	29"	1'-0"	1'-9"	2'-6"	0'-9"	4'-0"	10'-4"	2.072	0'-4 1/2"	0'-3"
* 40"	31"	1'-0"	1'-9"	2'-6"	0'-9"	4'-4"	11'-11"	2.520	0'-5 1/2"	0'-3 1/2"
49"	33"									
* 46"	36"									
57"	38"	1'-0"	2'-0"	2'-9"	0'-9"	4'-9"	13'-10"	3.427	0'-6"	0'-4"
* 53"	41"									

*3" x 1" AND 5" x 1" CORRUGATION DIMENSIONS.



ROAD AND BRIDGE STANDARDS

STANDARD ENDWALLS FOR PIPE ARCHES

13" - 38" RISE

VIRGINIA DEPARTMENT OF TRANSPORTATION

SPECIFICATION REFERENCE

SHEET 1 OF 1

REVISION DATE

105
302

101.22