



# COMMONWEALTH of VIRGINIA

## DEPARTMENT OF TRANSPORTATION

### DIVISION: Location & Design

### Road & Bridge Standards Revision

August 24, 2017:

EC-15 Page: 113.19

Drawings Prepared By Matthew Cross for : Jeffrey S. Bragdon, P.E.

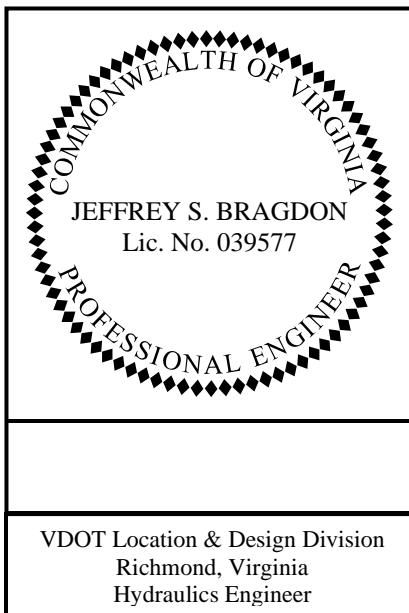

Responsible for attached Page

**NOTES:**

1. THE STANDARD FOR SEDIMENT RETENTION ROLLS (SRR) SHALL INCLUDE COMPOST FILTER SOCKS AND SEDIMENT TUBES, UNLESS SPECIFICALLY NOTED.
2. SRR SHALL BE INSTALLED PARALLEL TO THE SLOPE ALONG THE GROUND CONTOUR. SRR SHALL NOT BE INSTALLED WITHIN 10' OF THE TOE OF THE SLOPE. SRR SHALL NOT BE USED IN STREAMS.
3. COMPOST FILTER SOCKS USED IN SLOPE APPLICATIONS MAY REMAIN IN PLACE TO BIODEGRADE. SEDIMENT TUBES SHALL BE REMOVED FROM THE SLOPES AFTER STABILIZATION IS COMPLETE. THIS MAY BE ACCOMPLISHED BY CUTTING THE TUBE OPEN AND SPREADING THE FILL MATERIAL ON THE SITE. ALL NON-BIODEGRADABLE MATERIAL AND STAKES SHALL BE REMOVED.
4. ONLY SRR PRODUCTS LISTED ON THE VDOT APPROVED PRODUCTS LIST MAY BE USED.
5. SEDIMENT RETENTION ROLLS (SRR) USED FOR SLOPE APPLICATIONS WILL BE PAID IN ACCORDANCE WITH SECTION 603 OF THE SPECIFICATIONS.
6. PAYMENT SHALL INCLUDE ALL MATERIALS AND LABOR NECESSARY FOR INSTALLATION, MAINTENANCE AND REMOVAL.
7. SEDIMENT SHALL BE REMOVED FROM BEHIND THE SRR WHEN IT HAS ACCUMULATED TO ONE-HALF THE EXPOSED HEIGHT OF THE STRUCTURE AND PAID FOR AS SEDIMENT REMOVAL PER CUBIC YARD.
8. SRR SHALL BE INSTALLED WITH WOODEN STAKES (MIN. 1.5" X 1.5" ACTUAL). THE STAKE SHALL BE EMBEDDED A MINIMUM OF 2'.
9. IF MORE THAN ONE SRR IS PLACED IN A ROW IN A SLOPE APPLICATION, THE TUBES SHALL BE OVERLAPPED A MINIMUM OF 24" TO PREVENT FLOW AND SEDIMENT FROM PASSING THROUGH THE JOINT.
10. SRR SHALL NOT BE USED ON PAVEMENT, ROCKY SOILS, OR AT ANY OTHER LOCATION WHERE THE STAKES CANNOT BE DRIVEN TO THE REQUIRED DEPTH.

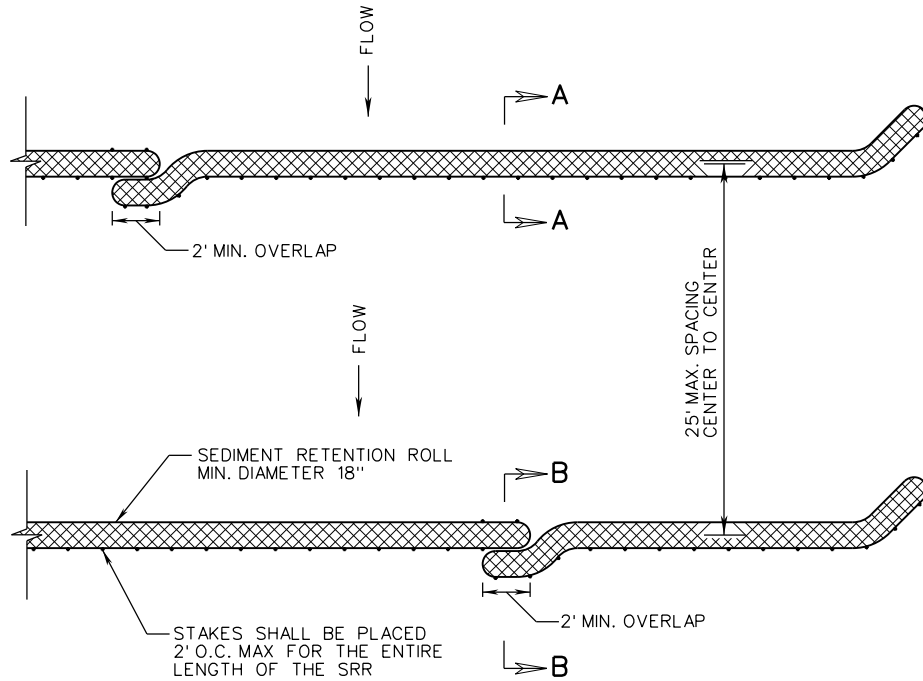

**PLAN**

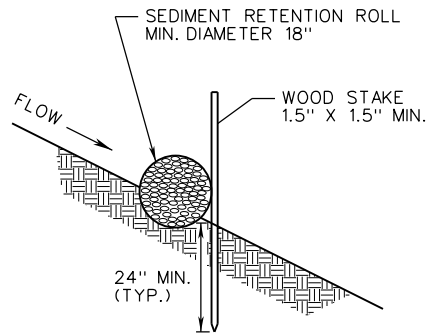

**SECTION A-A**

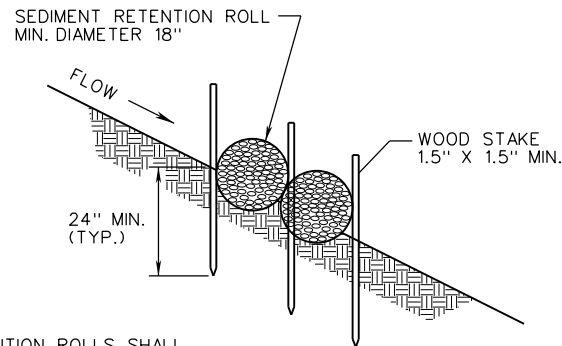

**SECTION B-B**

SEDIMENT RETENTION ROLLS SHALL BE EMBEDDED ONE THIRD THE SSR DIAMETER EXCEPT WHEN PLACED OVER STANDARD EC-2 OR EC-3.

SPECIFICATION REFERENCE
244 303 603

**SEDIMENT RETENTION ROLL  
SLOPE INTERRUPTER**

VIRGINIA DEPARTMENT OF TRANSPORTATION

<b>VDOT</b>	
ROAD AND BRIDGE STANDARDS	
REVISION DATE	SHEET 1 OF 1
08/17	113.19