

ISD-1

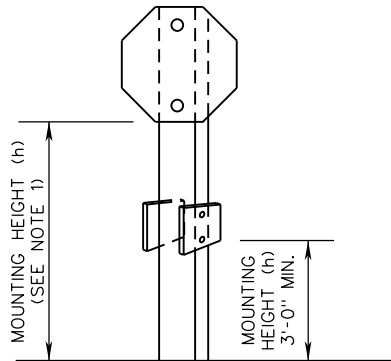

ONE WAY SIGNS
ON EXIT RAMP
WITH STOP SIGN

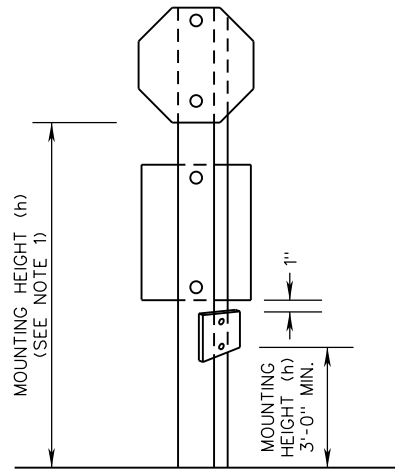

STOP OR YIELD SIGNS AND
DO NOT ENTER SIGN
(AT EXIT RAMP ONLY)

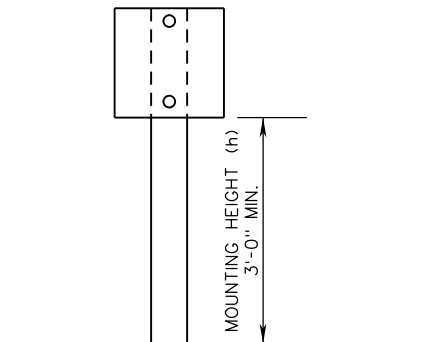

WRONG WAY SIGNS/
DO NOT ENTER SIGNS
(AT EXIT RAMP ONLY)

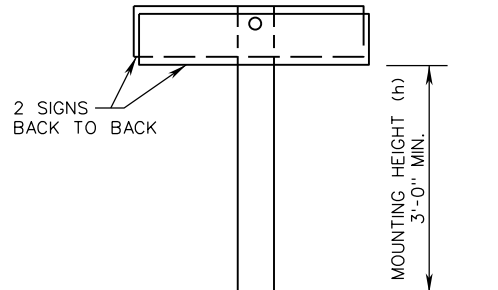

ONE WAY SIGNS
ON EXIT RAMP

NOTES:

1. MOUNTING HEIGHT (h) SHALL BE IN ACCORDANCE WITH STP-1 SHEET 1 OF 12 EXCEPT AS NOTED ON THIS SHEET.
2. MOUNTING HEIGHTS (h) ARE MEASURED FROM BOTTOM OF SIGN PANEL TO ROADWAY ELEVATION AT EDGE OF TRAVELWAY OR TOP OF CURB.

A COPY OF THE ORIGINAL SEALED AND SIGNED DRAWING IS ON FILE IN THE CENTRAL OFFICE.

VDOT ROAD AND BRIDGE STANDARDS	
SHEET 1 OF 1	REVISION DATE
1329.10	NEW 08/17

INTERCHANGE EXIT RAMP SIGNING DETAILS
MOUNTING HEIGHTS OF SIGN INSTALLATIONS

VIRGINIA DEPARTMENT OF TRANSPORTATION

SPECIFICATION REFERENCE
700