

**SINGLE POST - BRACING DIAGRAM  
TYPICAL - TWO BRACE**

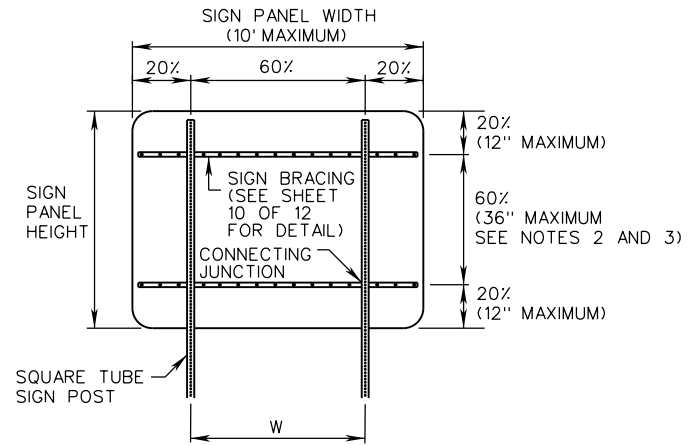

**TWO POST - BRACING DIAGRAM  
TYPICAL - TWO BRACE**

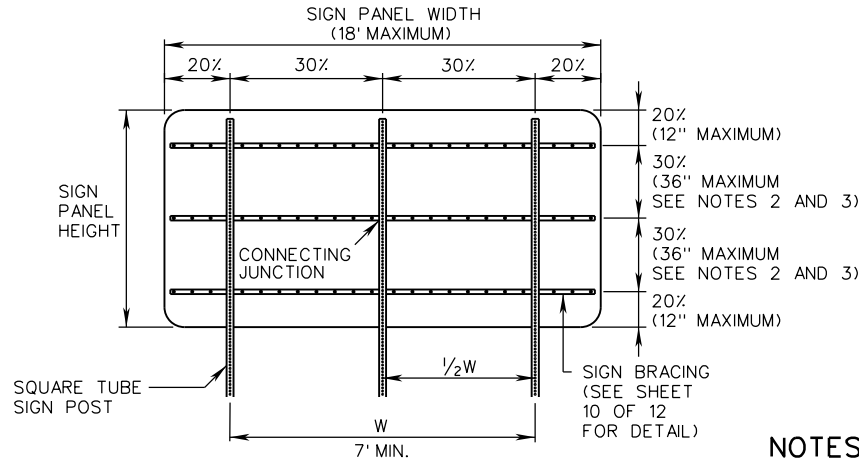

**THREE POST - BRACING DIAGRAM  
TYPICAL - THREE BRACE**

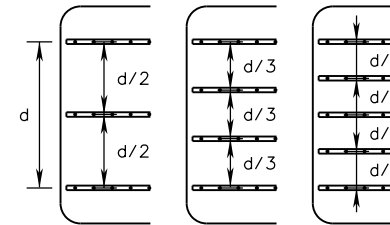

**DETAIL A - SPACING OF MULTIPLE BRACING**

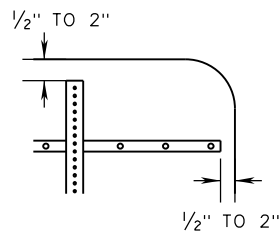

**DETAIL B - INSTALLATION TOLERANCES**

**NOTES:**

1. SIGN PANEL WIDTHS 36" OR GREATER SHALL REQUIRE SIGN BRACING.
2. VERTICAL SPACING OF SIGN BRACING SHALL NOT EXCEED 12" FROM THE TOP OR BOTTOM EDGE OF SIGN PANEL TO FIRST BRACE AND 36" BETWEEN BRACES. IF THE SPACING BETWEEN BRACES EXCEEDS 36" THEN ADDITIONAL SIGN BRACING SHALL BE ADDED. ALL SIGN BRACING SHALL BE EQUALLY SPACED BETWEEN THE TOP AND BOTTOM BRACE. SEE DETAIL A.
3. MAXIMUM SIGN PANEL AREA PER POST TO BRACE JUNCTION SHALL BE 10 SQ. FT. ADDITIONAL SIGN BRACING SHALL BE INSTALLED IF 10 SQ. FT PER POST TO BRACE JUNCTION IS EXCEEDED.
4. ONE SPLICE PER BRACE WILL BE PERMITTED. BRACE SPLICE SHALL BE IN ACCORDANCE WITH THE MANUFACTURER'S RECOMMENDATIONS. BRACING SHALL NOT BE SPLICED WITHIN 6" OF A BRACE TO POST JUNCTION. SPLICES SHALL NOT BE IN VERTICAL ALIGNMENT BUT SHALL BE OFFSET NO LESS THAN 12" FROM EACH OTHER.
5. TOP OF SIGN PANEL SHALL BE MOUNTED 1/2" TO 2" WITH THE TOP OF THE POST AND 1/2" TO 2" WITH THE SIDE OF THE SIGN BRACING. SEE DETAIL B.
6. SIGN PANEL WIDTHS SHALL NOT EXCEED MAXIMUM SPECIFIED.

SPECIFICATION REFERENCE
700

A COPY OF THE ORIGINAL SEALED AND SIGNED DRAWING IS ON FILE IN THE CENTRAL OFFICE.

**SQUARE TUBE SIGN POST**  
**SIGN BRACING DETAILS**

VIRGINIA DEPARTMENT OF TRANSPORTATION

<b>VDOT</b> ROAD AND BRIDGE STANDARDS	
REVISION DATE	SHEET 11 OF 12
08/17	1321.20