

3" STANDARD FOUNDRY LETTERS RECESSED 1/4" INTO TOP CONCRETE SURFACE. (SEE NOTE 3)

MASH 2016 00-0000

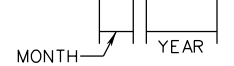

PLAN VIEW

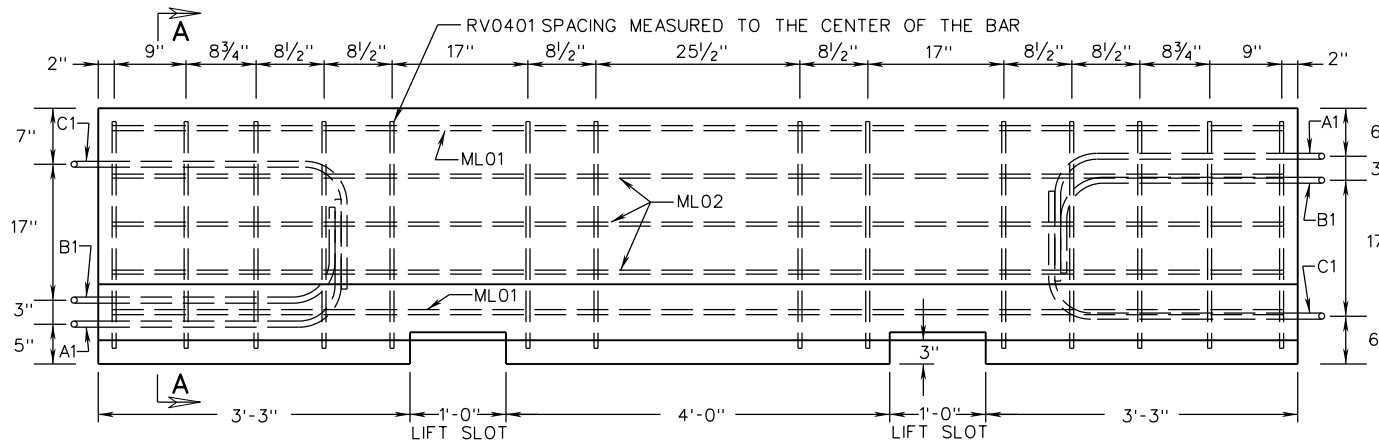

ELEVATION VIEW

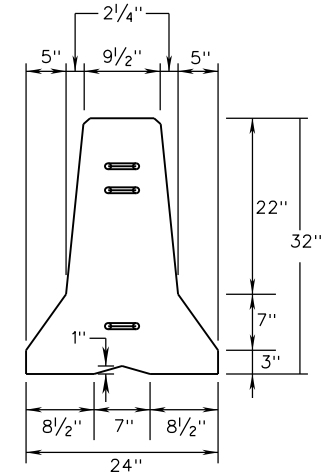

END VIEW

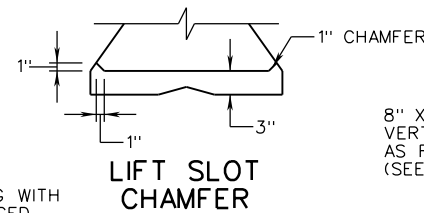

LIFT SLOT CHAMFER

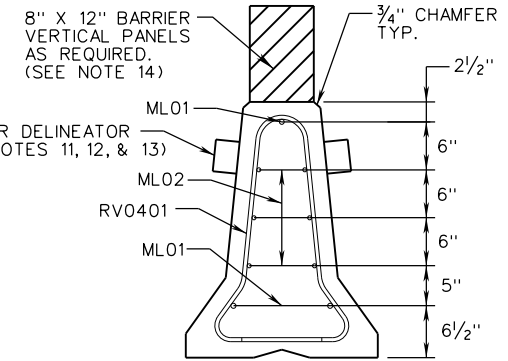

SECTION A-A

LONGITUDINAL REINFORCEMENT SPACING MEASURED TO THE CENTER OF THE BAR

NOTES:

1. THE TEMPORARY CONCRETE BARRIER SHALL BE PRECAST BY A VDOT APPROVED PRECAST MANUFACTURER. THE MANUFACTURER SHALL SUBMIT SHOP DRAWINGS FOR APPROVAL BY THE STANDARDS & SPECIAL DESIGN SECTION. MODIFICATIONS TO THIS DESIGN ARE NOT PERMITTED.
2. BARRIER SHALL HAVE A UNIFORM NATURAL CONCRETE FINISH. THE BARRIER SHALL NOT BE PAINTED OR COATED OTHER THAN MARKINGS NECESSARY TO IDENTIFY THE MANUFACTURER.
3. THE RECESSED LETTERING IN THE TOP OF THE BARRIER CONTAINING MASH 2016 ALONG WITH MONTH AND YEAR OF MANUFACTURE IS REQUIRED FOR EACH BARRIER SEGMENT PRODUCED.
4. CONCRETE SHALL BE A MINIMUM OF 5000 PSI.
5. ALL REINFORCING STEEL SHALL BE IN ACCORDANCE WITH ASTM-A615 GRADE 60.
6. ALL REINFORCING STEEL SHALL HAVE A MINIMUM COVER OF 2" UNLESS OTHERWISE SHOWN.
7. LOOP BARS SHALL NOT BE USED TO LIFT, MOVE, OR REPOSITION THE BARRIER.
8. ONLY ONE TYPE OF TEMPORARY BARRIER IS PERMITTED IN A RUN. MIXING TEMPORARY CONCRETE BARRIER WITH OTHER TEMPORARY CONCRETE BARRIERS IS NOT PERMITTED.
9. OTHER PRECAST TEMPORARY CONCRETE BARRIERS SHALL BE FROM THE MASH PROVISIONALLY APPROVED LIST. BARRIERS THAT HAVE BEEN APPROVED BY VDOT ON THE MASH PROVISIONALLY APPROVED LIST MAY BE SUBSTITUTED FOR THIS STANDARD.
10. MAXIMUM CROSS SLOPE FOR PLACEMENT OF TEMPORARY BARRIER WILL BE 10:1.
11. BARRIER DELINEATOR SIZE, COLOR AND SPACING SHALL BE IN ACCORDANCE WITH THE SPECIFICATIONS.
12. BARRIER DELINEATOR REFLECTIVE SURFACE IN ALL INSTANCES SHALL BE FACING ONCOMING TRAFFIC.
13. COST OF DELINEATOR SHALL BE INCLUDED IN THE PRICE BID FOR TEMPORARY CONCRETE BARRIER.
14. BARRIER VERTICAL PANELS SHALL BE SPACED IN ACCORDANCE WITH VIRGINIA WORK AREA PROTECTION MANUAL.

SPECIFICATION REFERENCE
105 512

A COPY OF THE ORIGINAL SEALED AND SIGNED DRAWING IS ON FILE IN THE CENTRAL OFFICE.

TEMPORARY CONCRETE BARRIER

(MASH FREESTANDING PRECAST PIN AND LOOP FOR TEMPORARY USE)

VIRGINIA DEPARTMENT OF TRANSPORTATION

VDOT	
ROAD AND BRIDGE STANDARDS	
REVISION DATE	SHEET 1 OF 3
NEW 04/20	509.01