

MOW STRIP/PAVEMENT PLAN

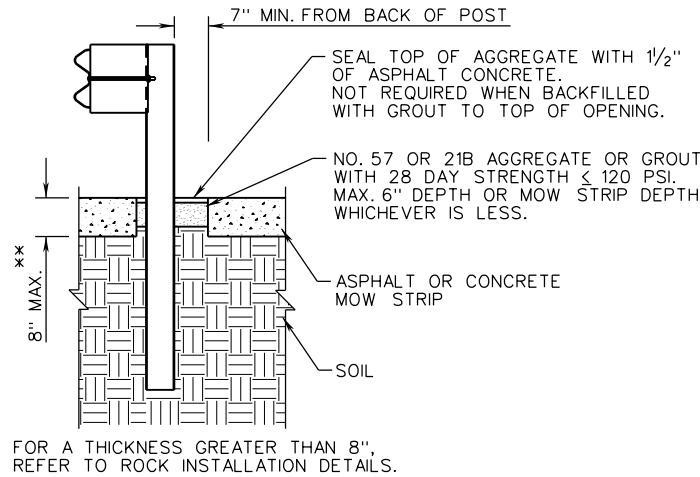

MOW STRIP/PAVEMENT ELEVATION

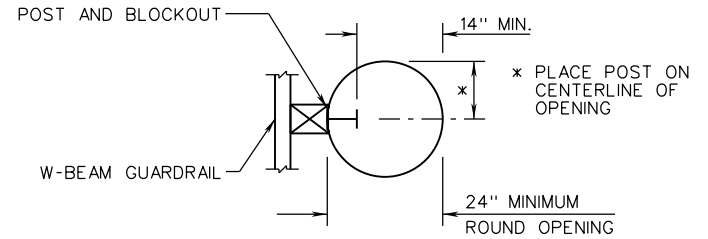

ROCK INSTALLATION PLAN VIEW

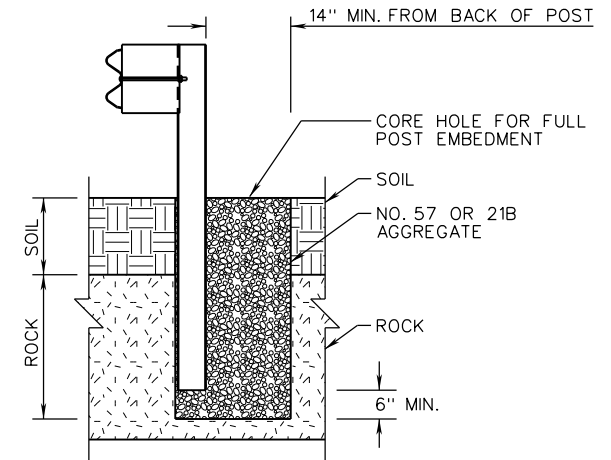

ROCK INSTALLATION ELEVATION

NOTES:

1. LEAVE-OUT ALLOWS FOR PROPER POST ROTATION.
2. DO NOT SHORTEN POST. POST SHALL HAVE FULL EMBEDMENT.
3. INSTALL POST AFTER OPENING IS BACKFILLED AND COMPACTED IN 6" LIFTS.

SPECIFICATION REFERENCE

221
505

A COPY OF THE ORIGINAL SEALED AND SIGNED DRAWING IS ON FILE IN THE CENTRAL OFFICE.

MGS W-BEAM GUARDRAIL INSTALLATION CRITERIA
(LEAVE-OUT FOR STANDARD GUARDRAIL POST INSTALLATION)

VIRGINIA DEPARTMENT OF TRANSPORTATION

VDOT

ROAD AND BRIDGE STANDARDS

REVISION DATE

NEW 04/19

SHEET 5 OF 5

507.05