

CG-12

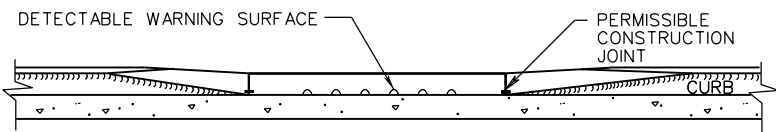

SECTION B-B

EXAMPLE INSTALLATION METHODS - SEE PLANS FOR LAYOUT

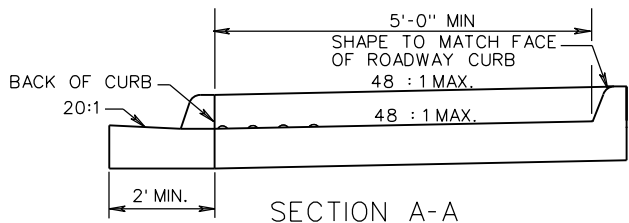
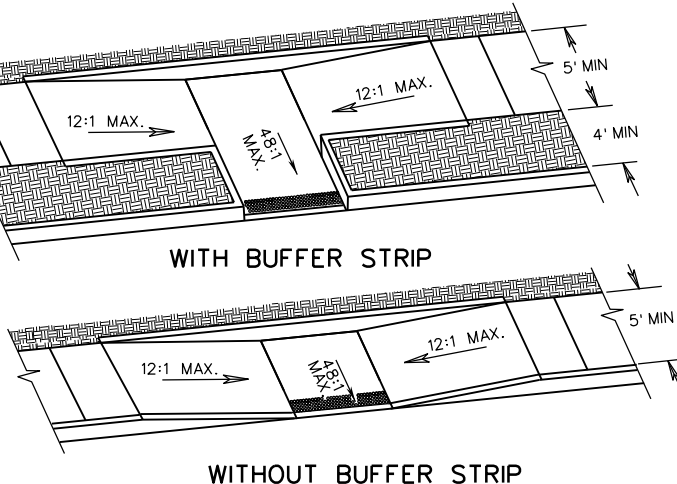
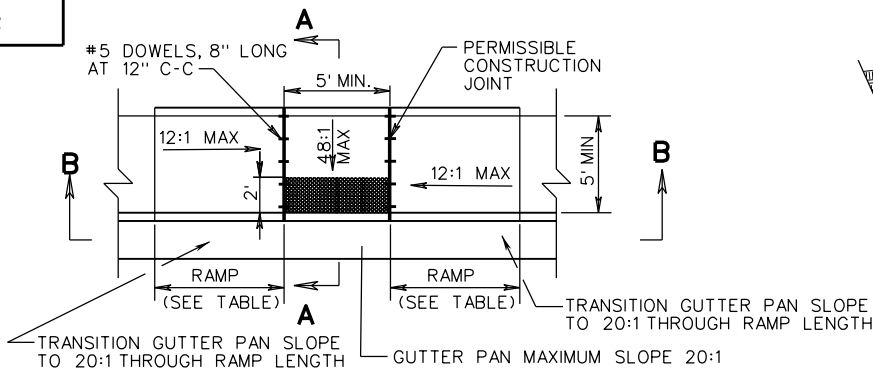
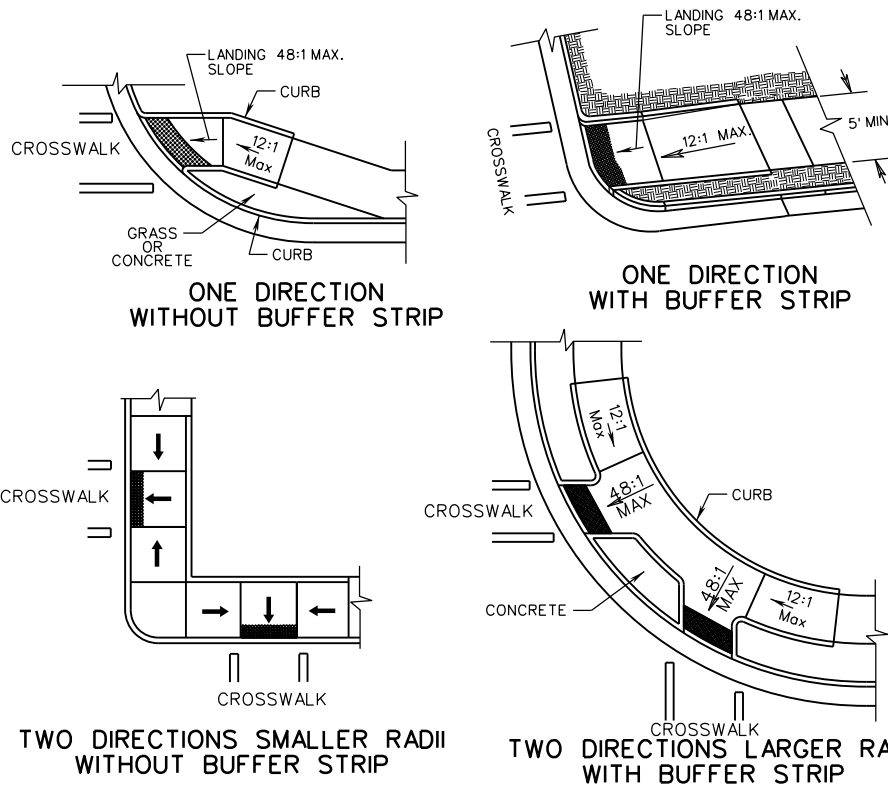

- NOTES:
1. FOR GENERAL NOTES ON THE DETECTABLE WARNING SURFACE, SEE SHEET 1 OF 5.
 2. THE REQUIRED LENGTH OF A PARALLEL RAMP IS LIMITED TO 15 FEET, REGARDLESS OF THE SLOPE.
 3. GUTTER PAN SHALL BE A MAXIMUM SLOPE OF 20:1 AT THE RAMP OPENING.
 4. DIAGONAL PLACEMENT IS NOT PERMITTED.

TYPE B PARALLEL APPLICATION		
ROADWAY GRADE IN PERCENT	MINIMUM RAMP LENGTH IN FEET	
	4" CURB	6" CURB
0	4	6
1	5	7
2	5	8
3	6	9
4	8	12
5	10	15
6	14	15

A COPY OF THE ORIGINAL SEALED AND SIGNED DRAWING IS ON FILE IN THE CENTRAL OFFICE.

CG-12 DETECTABLE WARNING SURFACE
TYPE B (PARALLEL) APPLICATION

VIRGINIA DEPARTMENT OF TRANSPORTATION

SPECIFICATION REFERENCE

- 105
- 502
- 504



ROAD AND BRIDGE STANDARDS

SHEET 3 OF 5

REVISION DATE

204.03

04/19