

GR-FOA-1

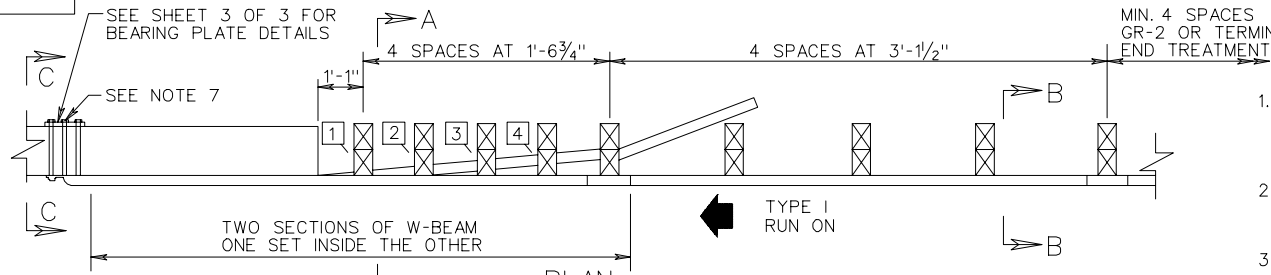

- NOTES:
1. FIXED OBJECTS MAY CONSIST OF BRIDGE RAILS, ABUTMENTS, PIERS, RETAINING WALLS, OR OTHER FLAT SURFACED STRUCTURES WITH VERTICAL FACE.
  2. BRIDGE RAIL ENDS AND BRIDGE PARAPETS MUST BE OF ADEQUATE STRENGTH TO ACCEPT FULL IMPACT LOADING.
  3. GUARDRAIL COMPONENTS SHALL BE IN ACCORDANCE WITH VDOT ROAD AND BRIDGE STANDARDS.
  4. POSTS 1, 2, 3, 4, AND 5 REQUIRE AN ADDITIONAL HOLE TO ATTACH BLOCKS AND/OR RUBRAIL RUBRAIL IS NOT BOLTED TO POSTS 2 AND 4.
  5. BOTTOM WOOD BLOCKS LOCATED ON POSTS 1 THROUGH 4 ARE CENTER DRILLED AND SECURED WITH 5/8" CARRIAGE BOLTS. (LENGTH AS REQUIRED).
  6. W-BEAM IS NOT BOLTED TO POST AT POSTS 2, 3, 6, AND 8; BOLT BLOCK DIRECTLY TO POST.
  7. APPROPRIATE LENGTH 7/8" DIAMETER ASTM A325 HEX BOLTS MUST BE USED WITH THRU DRILLED HOLES WITH A 5/8" BEARING PLATE ON THE BACK SIDE OF THE BRIDGE PARAPET OR TERMINAL WALL.
  8. DRIVE NAIL WITHIN 2" OF THE TOP OR BOTTOM OF THE BLOCKOUT AFTER 5/8" X 18 BOLT IS INSTALLED.

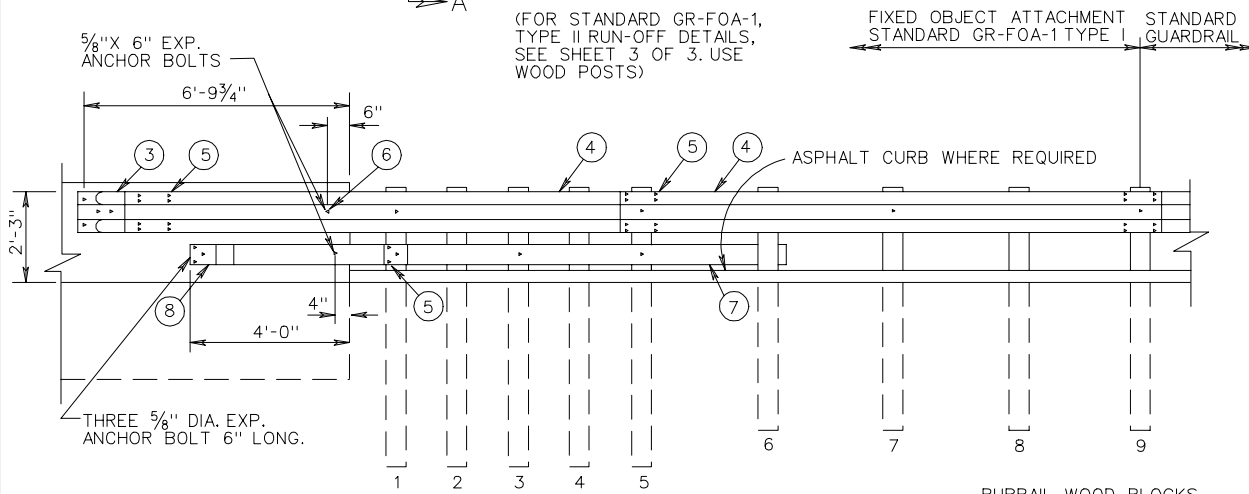

ELEVATION

RUBRAIL WOOD BLOCKS  
7"x6"xTHICKNESS

POST	THICKNESS
1	6 5/8"
2	5/16"
3	3 3/16"
4	2"

NEW BRIDGES - ATTACHMENTS  
 ONE WAY TRAFFIC - RUN-ON, 2-GR-FOA-1, TYPE I  
 - RUN-OFF, 2-GR-FOA-1, TYPE II  
 TWO WAY TRAFFIC - RUN-ON, 4-GR-FOA-1, TYPE I  
 EXISTING BRIDGE ATTACHMENTS AS SHOWN ON PLANS.

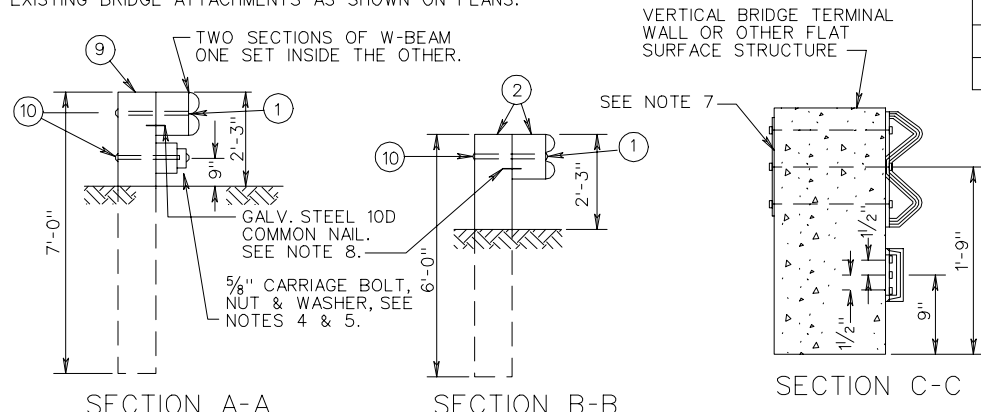

ITEM	MATERIAL/SPECIFICATIONS/NOTES
1	5/8" X 18" LONG. GUARDRAIL BOLT AND RECESSED NUT
2	STANDARD 6" X 8" WOOD POST AND BLOCK
3	STANDARD W-BEAM TERMINAL CONNECTOR
4	STANDARD W-BEAM RAIL
5	5/8" X 2" LONG GUARDRAIL BOLT & RECESSED NUT (SEE STANDARD GR-HDW)
6	RECTANGULAR PLATE WASHER (SEE STANDARD GR-HDW)
7	BENT PLATE RUBRAIL (SEE SHEET 3 OF 3)
8	C6 X 8.2 RUBRAIL (SEE SHEET 3 OF 3)
9	MOD. 6" X 8" WOOD POST & STANDARD BLOCK (7'-0" LENGTH POST)
10	WASHER FOR 5/8" BOLT

SHEET 1 OF 3

W-BEAM GUARDRAIL - FIXED OBJECT ATTACHMENT  
 FOR USE BETWEEN VERTICAL FIXED OBJECTS AND GUARDRAIL (WOOD POSTS)

SPECIFICATION REFERENCE
505