

NOTES:

1. THIS ITEM MAY BE PRECAST OR CAST IN PLACE.
2. CONCRETE TO BE CLASS A3 IF CAST IN PLACE, 4000 PSI IF PRECAST.
3. COMBINATION CURB & GUTTER HAVING A RADIUS OF 300 FEET OR LESS (ALONG FACE OF CURB) SHALL BE PAID FOR AS RADIAL COMBINATION CURB & GUTTER.
4. FOR USE WITH STABILIZED OPEN-GRADED DRAINAGE LAYER, THE BOTTOM OF THE CURB AND GUTTER SHALL BE CONSTRUCTED PARALLEL TO THE SLOPE OF SUBBASE COURSES AND TO THE DEPTH OF THE PAVEMENT.
5. THIS CURB MAY BE USED WITH ANY DESIGN SPEED BUT IS REQUIRED WHEN DESIGN SPEED IS GREATER THAN 40 MPH ON RURAL HIGHWAYS AND 45 MPH IN DEVELOPED URBAN & SUBURBAN AREAS.
6. WHEN THIS STANDARD IS TO BE TIED INTO EXISTING BARRIER CURB, THE TRANSITION IS TO BE MADE WITHIN 10' OR THE CHANGE IN STANDARDS MADE AT REGULAR OPENINGS.
7. WHEN COMBINATION MOUNTABLE CURB AND GUTTER IS USED, THE STANDARD ENTRANCE GUTTERS OR STANDARD CONNECTION FOR STREET INTERSECTIONS ARE TO HAVE THE MOUNTABLE CURB CONFIGURATION INCORPORATED.

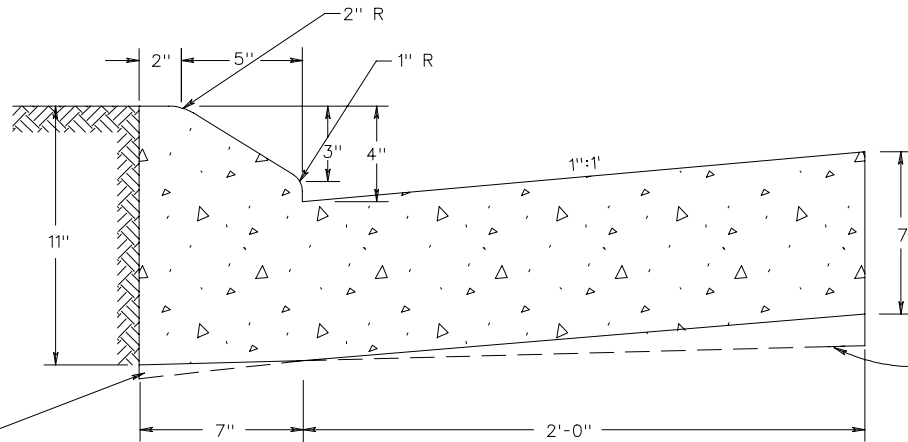

THIS AREA MAY BE CONCRETE AT THE OPTION OF THE CONTRACTOR

THE BOTTOM OF THE CURB AND GUTTER MAY BE CONSTRUCTED PARALLEL TO THE SLOPE OF SUBBASE COURSES PROVIDED A MIN. DEPTH OF 7" IS MAINTAINED

COMBINATION 4" CURB & GUTTER

VIRGINIA DEPARTMENT OF TRANSPORTATION

SPECIFICATION REFERENCE

105
502