

ELLIPTICAL FACTORY SHAPE  
(SHOP ELONGATED)

TYPE 1

Double Line of Min.  
8 ga. Wire on 2' Centers  
Min. Tensile Strength  
80,000 lbs./sq. in.

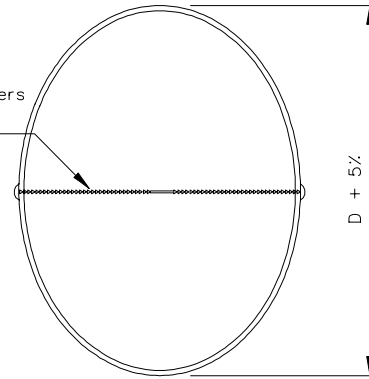

ELONGATED WITH WIRE

TYPE 2

Min. 4 ga. Rods  
on 2' Centers.  
Min. Tensile Strength  
80,000 lbs./sq. in.

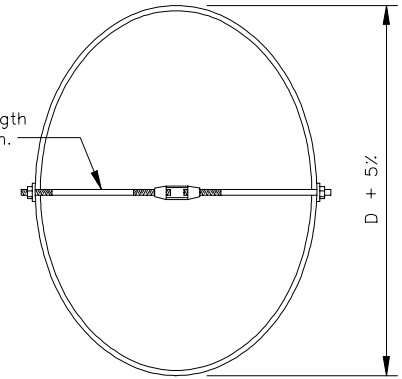

ELLIPTICAL WITH ROD  
AND TURNBUCKLE

TYPE 3

D = Diameter of round pipe

Note:

Wire or rod to be removed when fill reaches height specified for allowing construction traffic.

Methods shown apply to corrugated steel or corrugated aluminum alloy pipe.

Pipe size and cover height combinations requiring elongation are to be as tabulated on the applicable PC-1 tables or as shown on plans.

Any of above types of elongation may be used, unless otherwise noted on plans, special provisions, or directed by the Engineer.

Field elongation will not be permitted without the approval of the Engineer, or unless indicated on plans.

Elongation is to be performed prior to any required bituminous coating and paving of the invert.

Wire and rods to be attached to side of pipe in accordance with manufacturer's standard methods, meeting the approval of the Engineer.

SPECIFICATION  
REFERENCE

SHOP ELONGATION OF CORRUGATED  
METAL PIPE AND STRUCTURAL PLATE PIPE

VIRGINIA DEPARTMENT OF TRANSPORTATION