

REVISED ON 7/04

EW-12

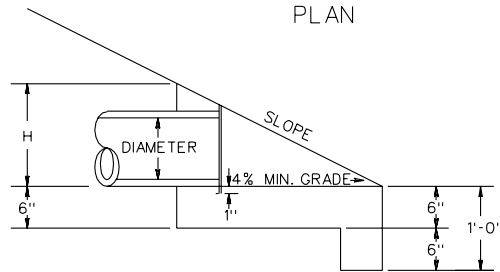

SECTION A-A

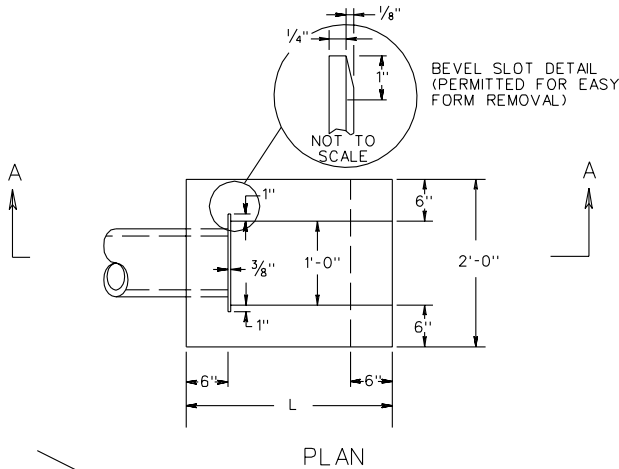
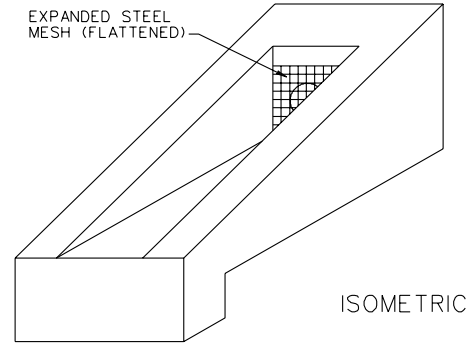

ISOMETRIC

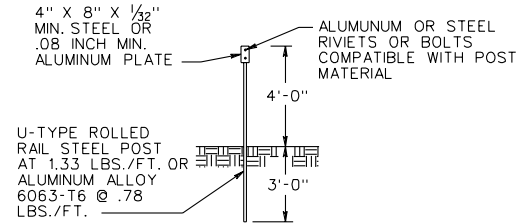

UNDERDRAIN OUTLET MARKER DETAIL

NOTES:

1. TYPICAL ENDWALL TO BE PLACED AT THE ENDS OF ALL UNDERDRAIN OUTLETS, BARRING LOCATIONS WHERE UNDERDRAIN IS TIED INTO OTHER DRAINAGE STRUCTURES. ENDWALL TO BE INSTALLED PERPENDICULAR TO ROADWAY AND FLUSH WITH THE SLOPE.
2. OUTLET PIPES SHALL BE RIGID NONPERFORATED, SMOOTH-BORE PIPE, MEETING THE REQUIREMENTS OF 70 PSI TESTED ACCORDING TO ASTM 2412.
3. EXPANDED STEEL MESH (FLATTENED) SHALL HAVE OPENINGS OF APPROX. 1/2" X 1" AND WEIGH APPROX. 0.82 LBS. PER SQ. FT. MESH SHALL BE GALVANIZED IN ACCORDANCE WITH ASTM A-123. THE MESH SHALL EXTEND A MINIMUM OF 1" ABOVE THE O.D. OF THE PIPE, AND IS A BARRIER FOR RODENTS, ETC. THE SLOT FOR THE STEEL MESH IS TO BE CONSTRUCTED SO THAT THE MESH CAN BE REMOVED FOR CLEANOUT PURPOSES.
4. THIS ITEM MAY BE PRECAST OR CAST IN PLACE.
5. STEEL POSTS AND PLATES TO BE PAINTED OR GALVANIZED IN ACCORDANCE WITH THE ROAD AND BRIDGE SPECIFICATIONS. IF PAINTED THE FINAL COAT SHALL BE NO. 13 ALUMINUM PAINT OR NO. 11 WHITE PAINT.
6. MARKER TO BE PLACED AT OUTLET END OF ALL UNDERDRAIN INSTALLATIONS BARRING LOCATIONS WHERE UNDERDRAIN IS TIED INTO OTHER DRAINAGE STRUCTURES.
7. MARKER WILL BE PAID FOR IN ACCORDANCE WITH SECTION 501 OF THE ROAD AND BRIDGE SPECIFICATIONS.

PIPE I.D.	SLOPE	DIMENSIONS		CLASS A3 CONCRETE CUBIC YARDS
		L	H	
4"	2:1	2'-5 1/2"	1'-2 3/4"	0.17
4"	4:1	4'-5"	1'-1 1/4"	0.28
6"	2:1	2'-10 1/2"	1'-5 1/4"	0.21
6"	4:1	5'-3"	1'-3 3/4"	0.35

REV. 7/03

STANDARD ENDWALL FOR PIPE UNDERDRAIN

VIRGINIA DEPARTMENT OF TRANSPORTATION

101.32

SPECIFICATION REFERENCE

105  
233  
302  
501