

NOTES:

1. GRATE AND COLLAR ARE TO BE GALVANIZED AFTER FABRICATION. COST OF THIS GRATE AND COLLAR ARE TO BE INCLUDED IN THE PRICE BID FOR STORMWATER MANAGEMENT DRAINAGE STRUCTURE.
2. STRUCTURE MAY BE PRECAST OR CAST IN PLACE. SEE SHEET 2 OF 3 FOR DETAILS ON PRECAST STRUCTURE.
3. WEEP HOLES SHALL NOT BE PROVIDED.
4. STEPS ARE TO BE PROVIDED WHEN HEIGHT OF STRUCTURE IS 4'-0" OR GREATER ABOVE INVERT OF OUTLET PIPE. FOR STEP DETAILS SEE STANDARD ST-1.
5. FOR DETAILS ON METAL PLATE AND DEBRIS RACK SEE STANDARD SWM-DR.
6. MARK HEIGHT OF STRUCTURE, IN BLACK, WITH 4" HIGH NUMERALS AND 1" WIDE HORIZONTAL STRIPES AT 1' INTERVALS FROM INVERT OF WATER QUALITY ORIFICE (ALL VISIBLE SIDES).
7. STORMWATER MANAGEMENT DRAINAGE STRUCTURE, STANDARD SWM-1, MAY BE USED AS A TEMPORARY SEDIMENT BASIN DURING CONSTRUCTION. SEE STANDARD SWM-DR, SHEET 1 OF 3, FOR TEMPORARY SEDIMENT BASIN DETAILS.

APPROXIMATE QUANTITIES  
CAST-IN-PLACE CLASS A-3 CONCRETE TO BE USED.  
MAXIMUM DEPTH (H) TO BE 12'-8".

PIPE SIZE	12"	15"	18"	24"	30"	36"	42"
MINIMUM DEPTH H	5'-0"	5'-3/4"	5'-6 1/2"	6'-1"	6'-7 1/2"	7'-2"	7'-8 1/2"
CU. YDS. CONCRETE	3.088	3.196	3.301	3.501	3.687	3.860	4.021

INCREMENT PER FOOT OF ADDITIONAL DEPTH "H" = 0.461 CU. YDS.

SHEET 1 OF 3

SPECIFICATION REFERENCE
302

STORMWATER MANAGEMENT  
DRAINAGE STRUCTURE  
VIRGINIA DEPARTMENT OF TRANSPORTATION

SWM-1

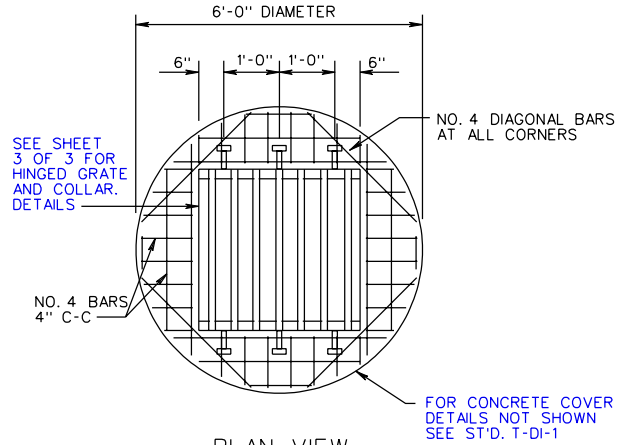

PLAN VIEW

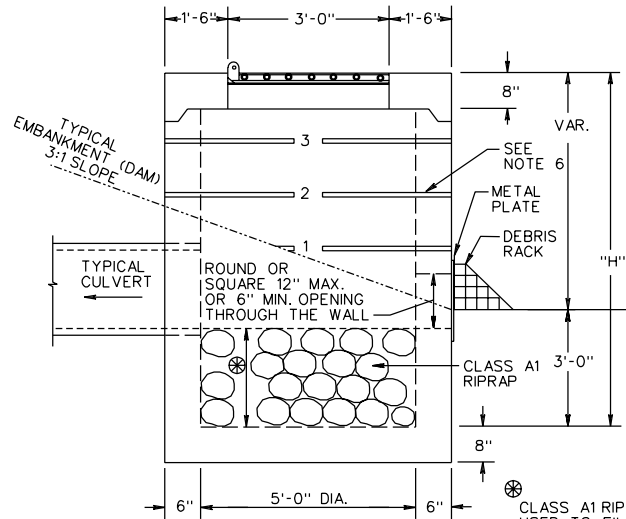

SIDE VIEW  
SWM DRAINAGE STRUCTURE

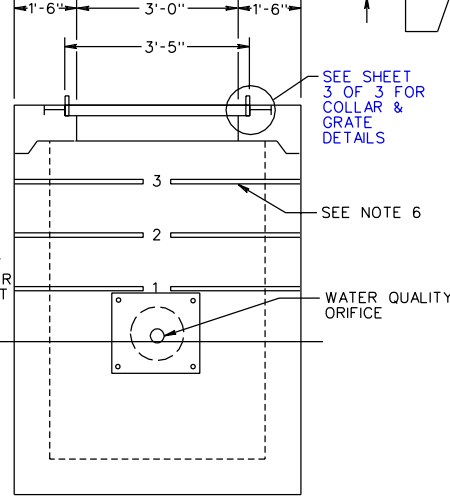

FRONT VIEW  
(DEBRIS RACK NOT SHOWN)

NOTES:

1. GRATE AND COLLAR ARE TO BE GALVANIZED AFTER FABRICATION. COST OF THIS GRATE AND COLLAR ARE TO BE INCLUDED IN THE PRICE BID FOR STORMWATER MANAGEMENT DRAINAGE STRUCTURE.
2. STRUCTURE MAY BE PRECAST OR CAST IN PLACE. SEE SHEET 1 OF 3 FOR DETAILS ON CAST IN PLACE STRUCTURE.
3. WEEP HOLES SHALL NOT BE PROVIDED. ANY LIFT HOLES SHALL BE PLUGGED.
4. STEPS ARE TO BE PROVIDED WHEN HEIGHT OF STRUCTURE IS 4'-0" OR GREATER ABOVE INVERT OF OUTLET PIPE. FOR STEP DETAILS SEE STANDARD ST-1.
5. FOR DETAILS ON METAL PLATE AND DEBRIS RACK SEE STANDARD SWM-DR.
6. MARK HEIGHT OF STRUCTURE, IN BLACK, WITH 4" HIGH NUMERALS AND 1" WIDE HORIZONTAL STRIPES AT 1' INTERVALS FROM INVERT OF WATER QUALITY ORIFICE (ALL VISIBLE SIDES).
7. STORMWATER MANAGEMENT DRAINAGE STRUCTURE, STANDARD SWM-1, MAY BE USED AS TEMPORARY SEDIMENT BASIN DURING CONSTRUCTION. SEE STANDARD SWM-DR, SHEET 1 OF 3, FOR TEMPORARY SEDIMENT BASIN DETAILS.

SHEET 2 OF 3

PRECAST STORMWATER MANAGEMENT DRAINAGE STRUCTURE

VIRGINIA DEPARTMENT OF TRANSPORTATION

116.02

SPECIFICATION REFERENCE

105 302

VOID ON 3/03

SWM-1

NOTE:

GRATE AND COLLAR ARE TO BE GALVANIZED AFTER FABRICATION. COST OF THIS GRATE AND COLLAR ARE TO BE INCLUDED IN THE PRICE BID FOR STORMWATER MANAGEMENT DRAINAGE STRUCTURE.

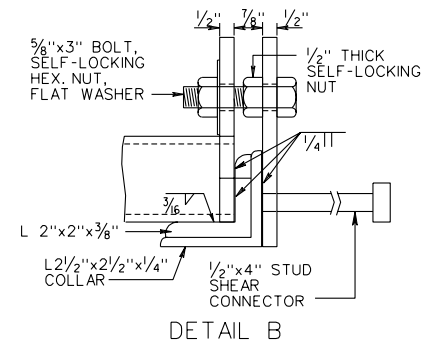
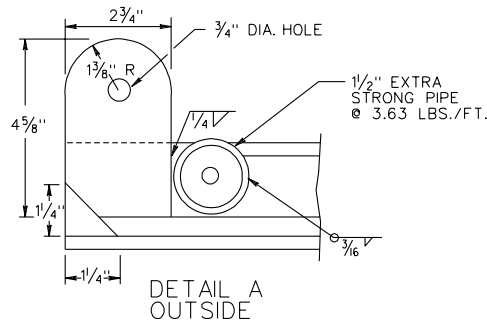
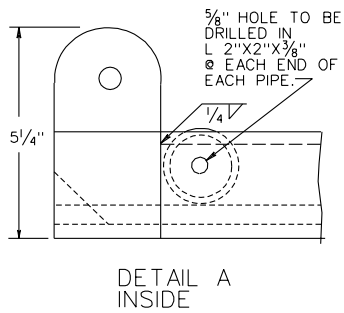
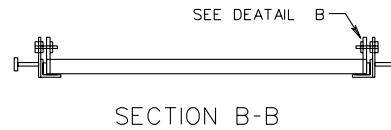
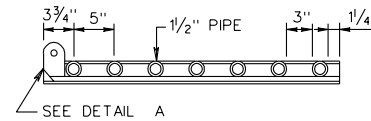
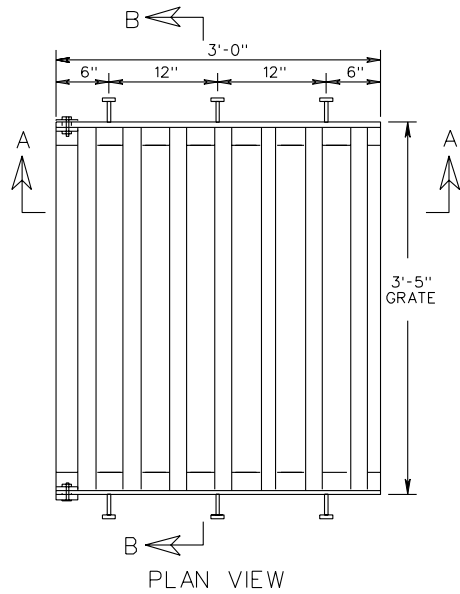

SHEET 3 OF 3

SPECIFICATION REFERENCE	<p>STORMWATER MANAGEMENT DRAINAGE STRUCTURE GRATE DETAILS</p> <p>VIRGINIA DEPARTMENT OF TRANSPORTATION</p>	<p>VOID ON 3/03</p>
302		

REVISED ON 3/03

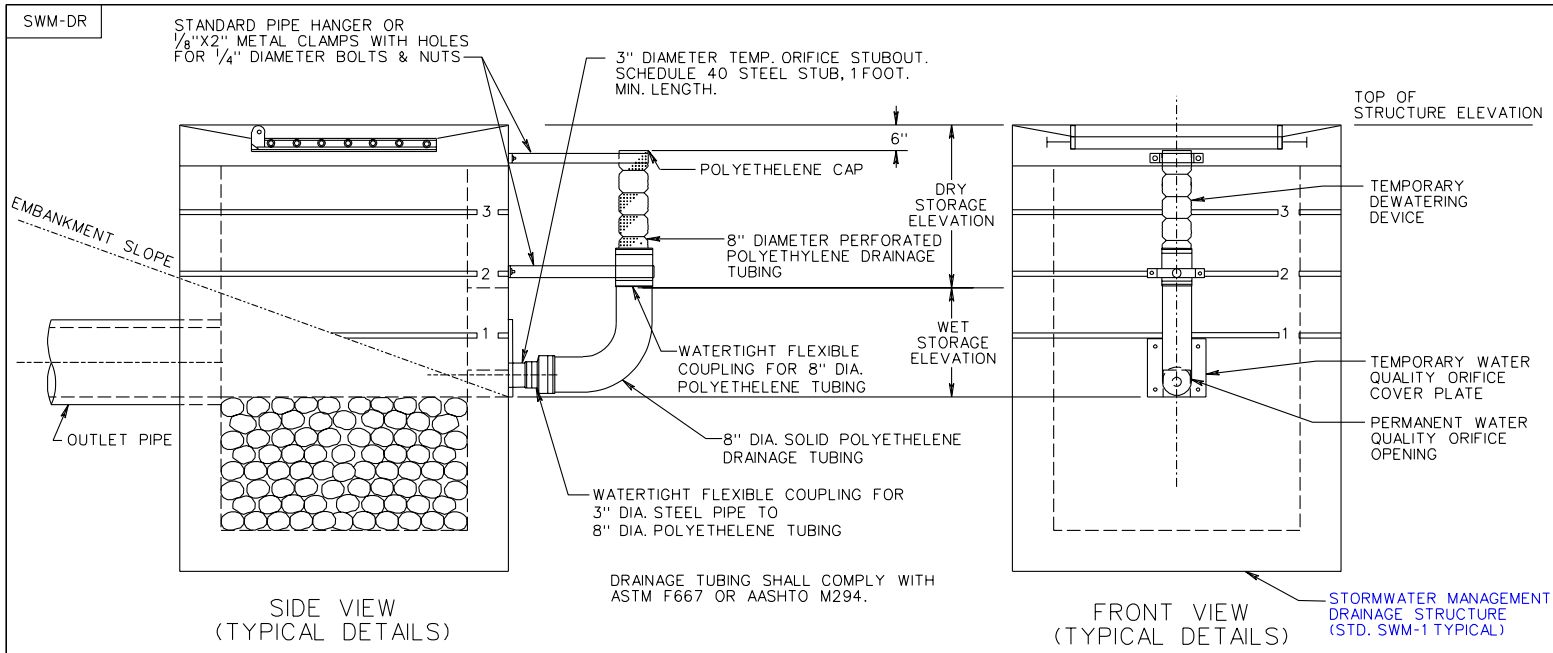

SIDE VIEW  
(TYPICAL DETAILS)

FRONT VIEW  
(TYPICAL DETAILS)

DRAINAGE TUBING SHALL COMPLY WITH  
ASTM F667 OR AASHTO M294.

STORMWATER MANAGEMENT  
DRAINAGE STRUCTURE  
(STD. SWM-1 TYPICAL)

NOTE:

1. THESE DETAILS ARE TO BE USED TO MODIFY THE PERMANENT STORMWATER MANAGEMENT DRAINAGE STRUCTURE WHERE THE STORMWATER MANAGEMENT BASIN IS TO BE USED FOR A TEMPORARY SEDIMENT BASIN DURING PROJECT CONSTRUCTION.
2. GRADE STORMWATER MANAGEMENT BASIN AS SHOWN IN PLANS.
3. ALL OPENINGS (IF ANY) IN SIDE OF STRUCTURE (OTHER THEN PERMANENT WATER QUALITY ORIFICE) ARE TO BE COVERED WITH SOLID METAL PLATES WHILE THE BASIN IS BEING USED FOR SEDIMENT CONTROL.
4. DEWATERING DEVICE AND COMPONENTS AND TEMPORARY METAL PLATES (IF ANY), AS SHOWN IN THE DETAIL, ARE TO BE REMOVED AND PERMANENT STEEL PLATE WITH WATER QUALITY ORIFICE IS TO BE INSTALLED WHEN BASIN IS NO LONGER NEEDED FOR SEDIMENT CONTROL.
5. SIMILAR DEVICE MAY ALSO BE USED ON OTHER STORMWATER MANAGEMENT DRAINAGE STRUCTURES.
6. COST OF TEMPORARY DEWATERING DEVICE AND TEMPORARY METAL PLATES (IF ANY) SHALL BE INCLUDED IN THE BID PRICE FOR STORMWATER MANAGEMENT DRAINAGE STRUCTURE.
7. THE TEMPORARY 8" DIA. POLYETHYLENE DRAINAGE TUBING IS TO BE SOLID FOR THE LENGTH BELOW WET STORAGE ELEVATION AND IS TO BE PERFORATED ABOVE THE WET STORAGE ELEVATION. THE COUPLING IS TO BE WATERTIGHT.

SHEET 1 OF 3

STORMWATER MANAGEMENT (SWM) DETAILS

SPECIFICATION  
REFERENCE

302

116.04

VIRGINIA DEPARTMENT OF TRANSPORTATION

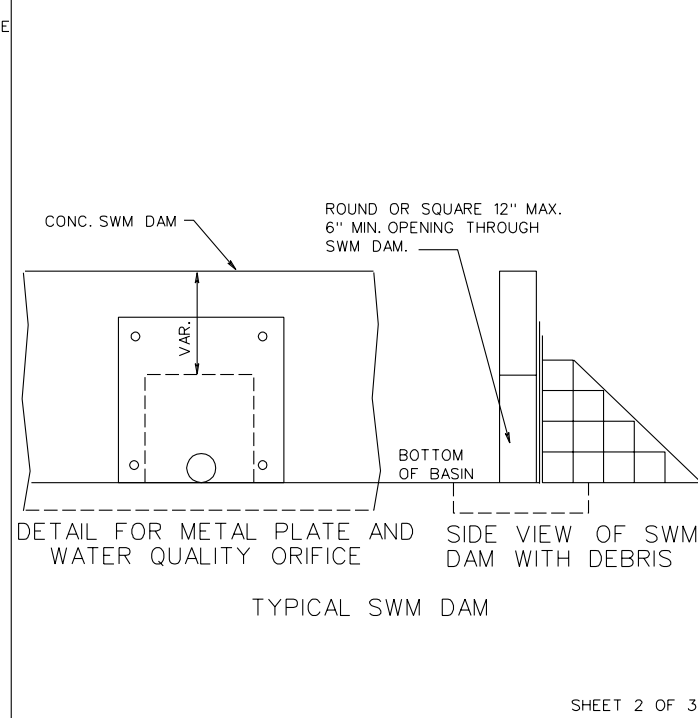
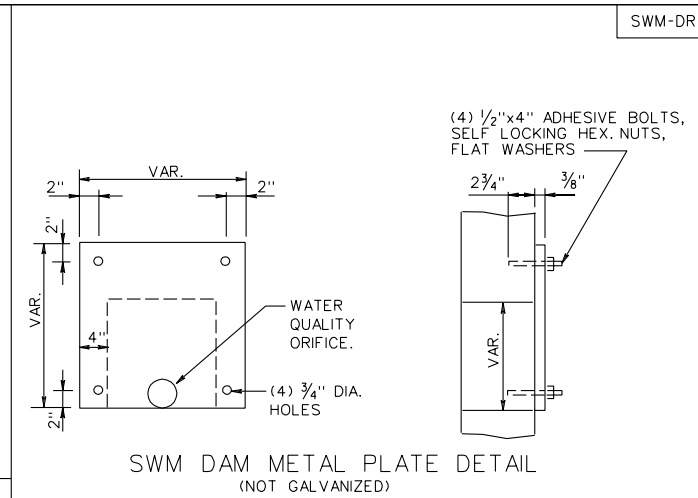
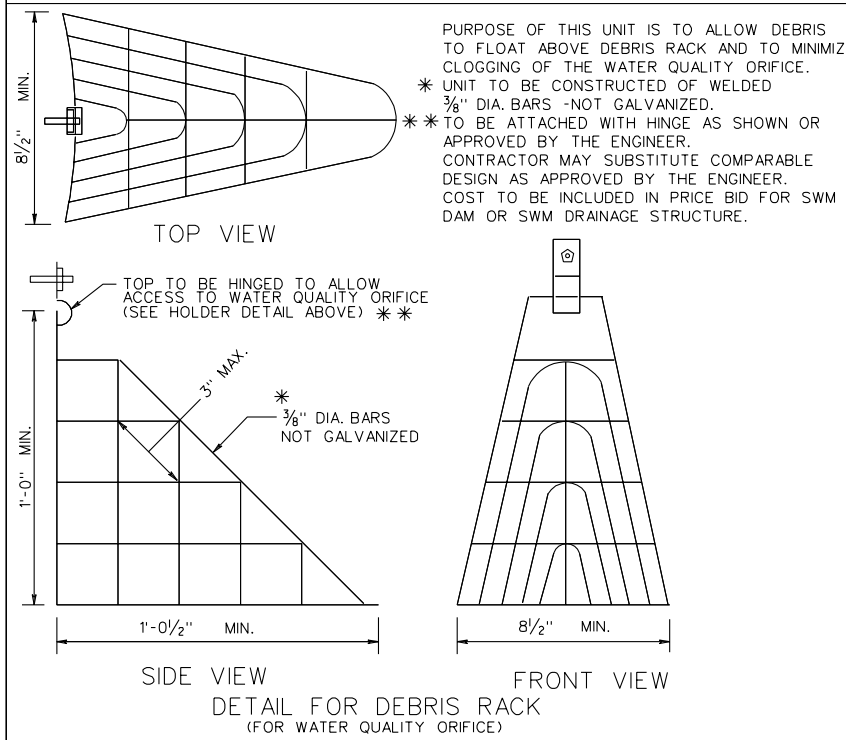
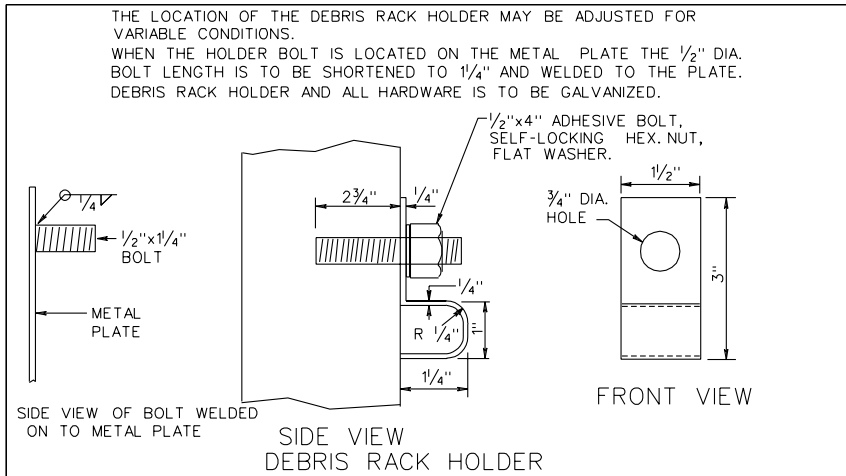

SPECIFICATION REFERENCE	STORMWATER MANAGEMENT (SWM) DETAILS
302	DEBRIS RACK, METAL PLATE, WATER QUALITY ORIFICE, CONCRETE CRADLE (FOR SWM DRAINAGE STRUCTURES, SWM RISER PIPES AND SWM DAMS) VIRGINIA DEPARTMENT OF TRANSPORTATION

SWM-DR

NOTES:

TO PROVIDE THE REQUIRED WATER QUALITY ORIFICE, ALL STORMWATER MANAGEMENT (SWM) BASINS SHALL BE CONSTRUCTED WITH THE FOLLOWING:

1. FOR SWM DRAINAGE STRUCTURES, SWM DAMS OR SWM RISER PIPES OF CONCRETE, AN OPENING SHALL BE PROVIDED IN THE CONCRETE WALL: 12" MAX. OR 6" MIN. AND SHALL BE COVERED WITH THE 3/8" METAL PLATE.
2. DEBRIS RACK SHALL BE ATTACHED TO SWM DRAINAGE STRUCTURE, SWM DAM OR SWM RISER PIPE TO COVER WATER QUALITY ORIFICE.
3. SIZE OF WATER QUALITY ORIFICE IS TO BE SPECIFIED FOR EACH BASIN.

FOR DETAILS OF SWM DRAINAGE STRUCTURE SEE STANDARD SWM-1.

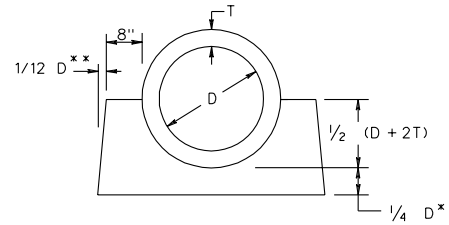

CONCRETE CRADLE

- \* BUT NOT LESS THAN 6"
- \*\* IF THE PIPE IS LAID IN AN EXCAVATED TRENCH, THEN THE SIDE WALLS MAY CONFORM TO THE TRENCH SHAPE (IE THE TRENCH MAY BECOME THE CRADLE FORM).

CONCRETE CRADLE IS TO BE INSTALLED UNDER THE ENTIRE LENGTH OF CULVERT AT EACH STORMWATER MANAGEMENT BASIN.

CONCRETE CRADLE IS TO BE PAID FOR AS MISCELLANEOUS CONCRETE AND SUMMARIZED AS EACH PER LOCATION.

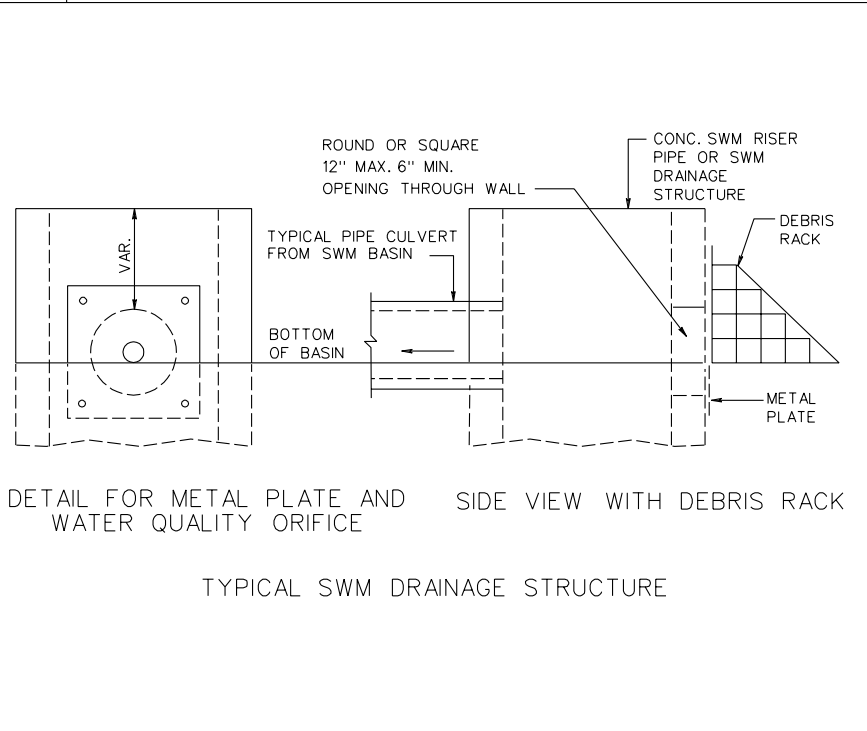
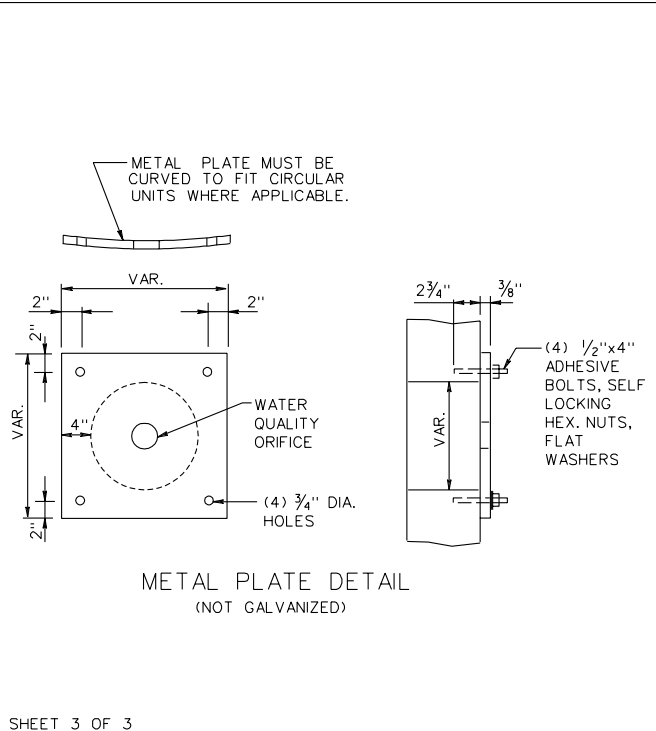

SHEET 3 OF 3

STORMWATER MANAGEMENT (SWM) DETAILS

DEBRIS RACK, METAL PLATE, WATER QUALITY ORIFICE, CONCRETE CRADLE (FOR SWM DRAINAGE STRUCTURES, SWM RISER PIPES AND SWM DAMS)

SPECIFICATION REFERENCE

302