

NOTES:

NO SEPARATE PAYMENT WILL BE MADE FOR FURNISHING, INSTALLING AND PROVIDING MAINTENANCE OF THE STORAGE FACILITY FOR NUCLEAR GAUGE AND THE PRICE THEREOF SHALL BE INCLUDED IN THE PRICE BID FOR FIELD OFFICE (TYPE) SPECIFIED, IN ACCORDANCE WITH SECTION 514 OF THE CURRENT ROAD AND BRIDGE SPECIFICATIONS. BOX TO BE CONSTRUCTED OF A-36 SHEET STEEL  $\frac{1}{8}$ " MIN. THICKNESS. WHEN WELDING TO FRAME USE  $\frac{1}{8}$ " FILLET WELDS. ALL FRAME WORK IS TO BE A-36 STEEL ANGLE L 2" X 2" X  $\frac{1}{4}$ ". ALL FRAME WELDS ARE TO BE  $\frac{1}{4}$ " FILLET OR BUTT WELDED ACCORDINGLY. METAL SCREEN SHALL HAVE A MAXIMUM OF 50 SQUARES PER INCH TO A MINIMUM OF 25 SQUARES PER INCH AND BE SPOT WELDED TO INSIDE OF THE BOX OVER VENT OPENINGS. VENT OPENINGS SHALL BE PARTIALLY COVERED EXTERNALLY BY METAL VENT COVERS.

△ THE HOOK SHALL BE WELDED TO THE CENTER OF THE TOP. STORAGE UNIT SHALL BE PAINTED INTERNALLY AND EXTERNALLY WITH A ONE COAT ACRYLIC DIRECT TO METAL (DTM) COATING, WITH A THICKNESS OF 4-6 MILS (WET MIL THICKNESS). COLOR SHALL BE EQUAL TO FEDERAL STANDARD COLOR NO. 595-17886 (WHITE).

☒ USE OF A CYLINDRICAL DESIGN IS AN ALLOWABLE OPTION FOR THE STEEL BOX SHROUD. THE DESIGN IS TO BE 4" ID AND MOUNTED AT A 45° ANGLE OVER THE HASP OPENING IN THE DOOR.

OPTIONAL SHROUD DESIGN IS TO BE SUBMITTED FOR THE ENGINEERS REVIEW AND APPROVAL.

STORAGE AREA FOR RADIOACTIVE SOURCE IS TO BE PAINTED ON FLOOR TO SHOW THAT A MINIMUM 12" SPACE IS TO BE MAINTAINED FROM THE GAUGE TO THE EXPOSED WALL. CONTRASTING PAINT IS REQUIRED TO DEPICT STORAGE AREA.

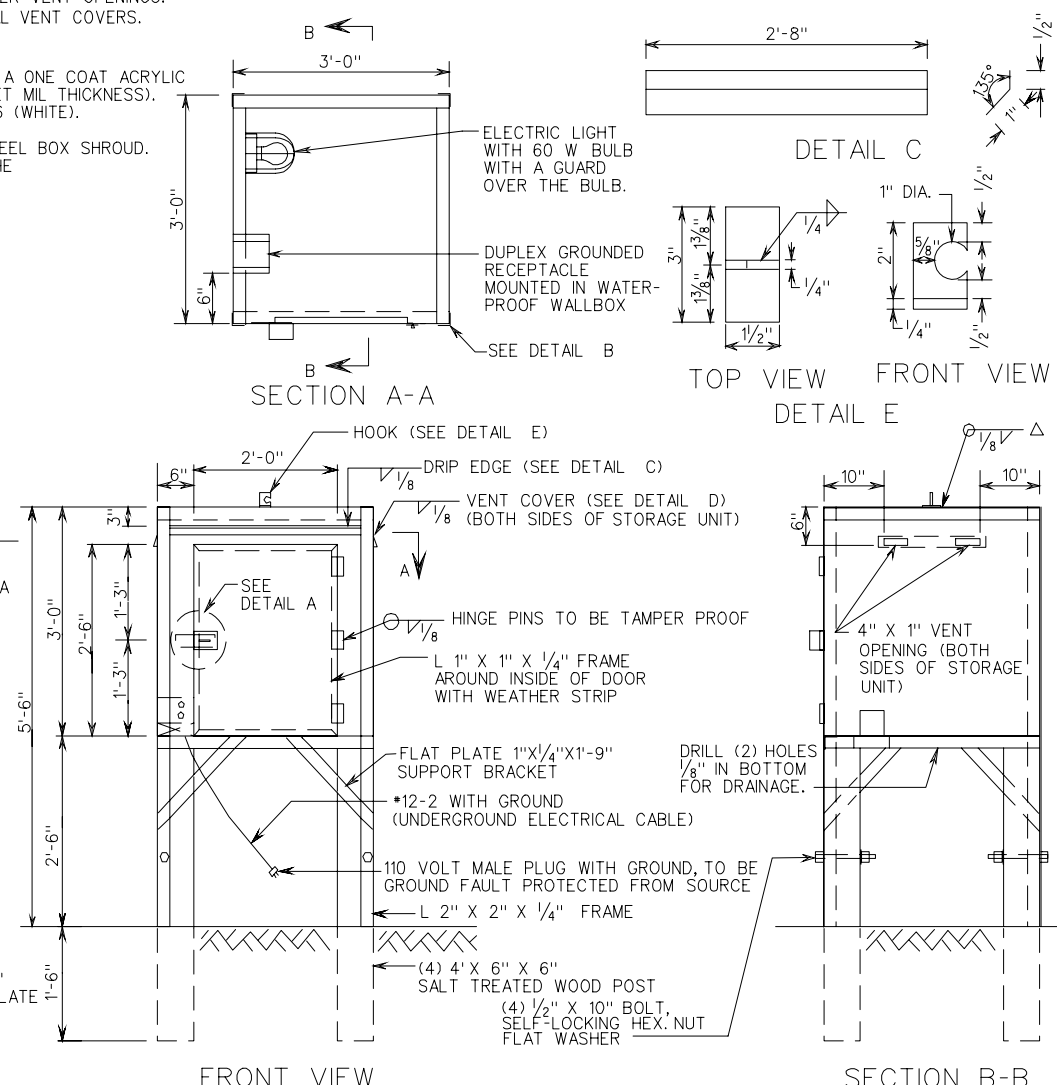
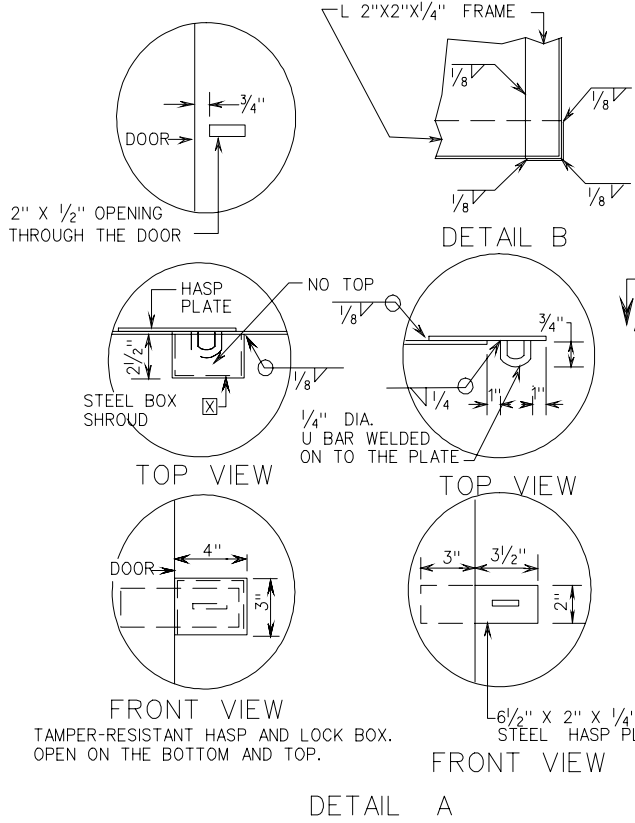

|                         |
|-------------------------|
| SPECIFICATION REFERENCE |
|                         |

STORAGE FACILITY FOR NUCLEAR GAUGE

VIRGINIA DEPARTMENT OF TRANSPORTATION