

LONGITUDINAL SECTION
(WHEN INLET IS LOCATED ABOVE NORMAL DITCH GRADE)
SEE NOTE 16.

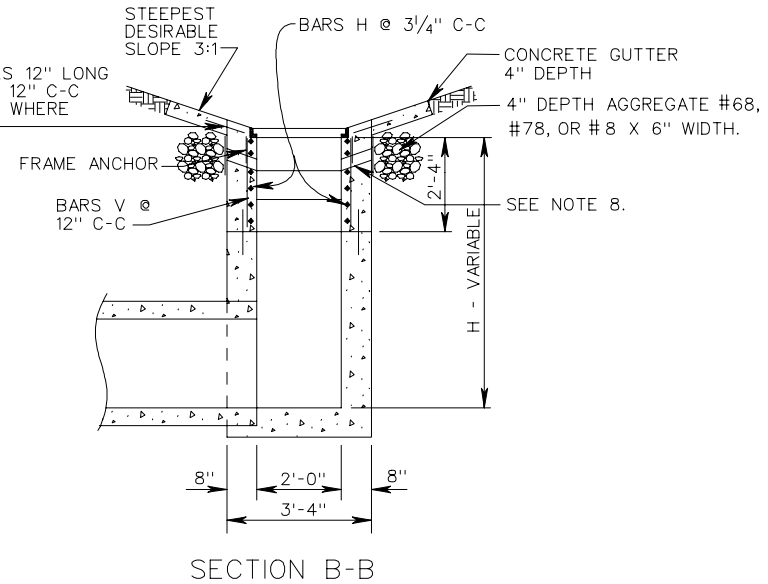
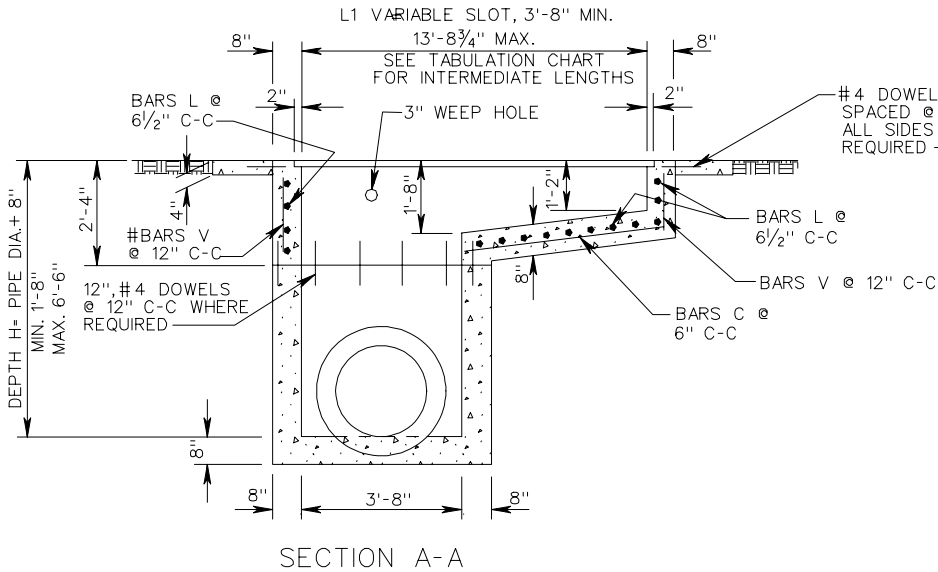

MULTIGRATE DROP INLET
FOR PIPE SIZES 12" TO 36"
VIRGINIA DEPARTMENT OF TRANSPORTATION