

REVISED ON 1-04

MB-8A

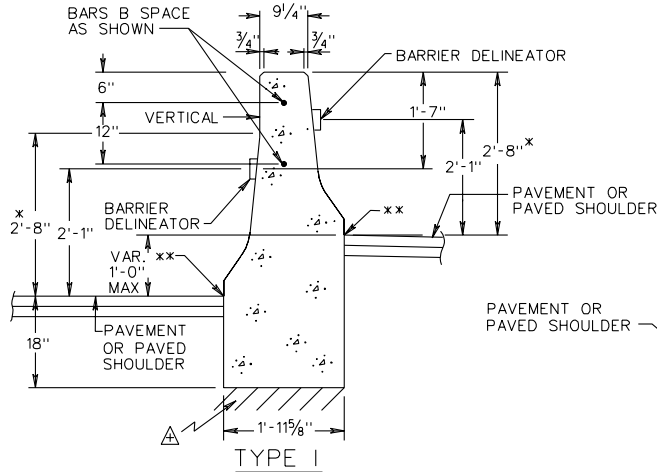

TYPE I (GREATER THAN 0 HT. DIFF., MAX. 1'-0")

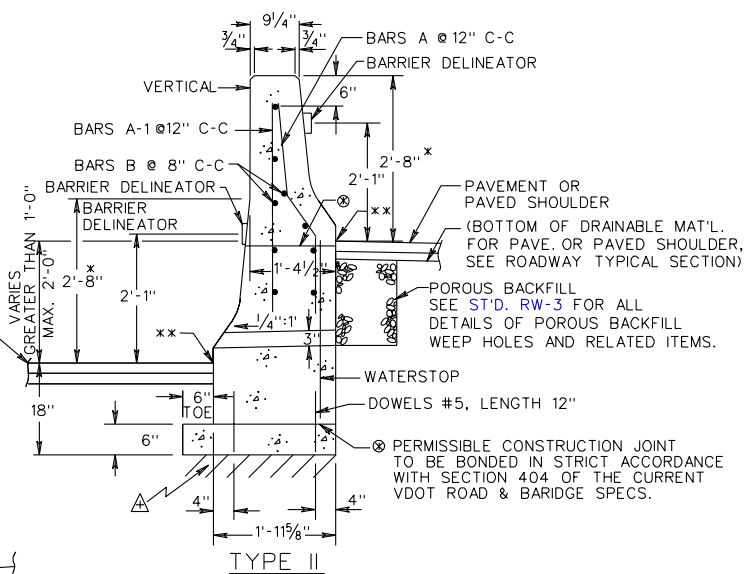
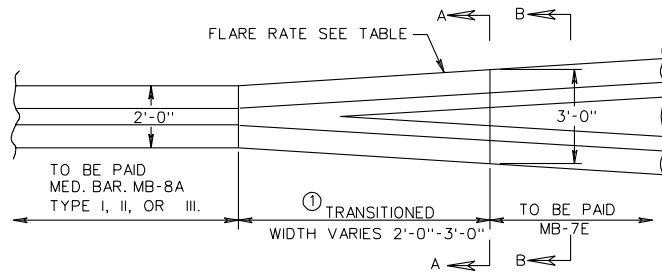

TYPE II (GREATER THAN 1'-0" HT. DIFF., MAX. 2'-0")

x MB-7D BARRIER FACE

** DENOTES FINISHED GRADE ELEVATION

△ FOUNDATION MATERIAL UNDER MEDIAN BARRIER IS TO BE COMPACTED.

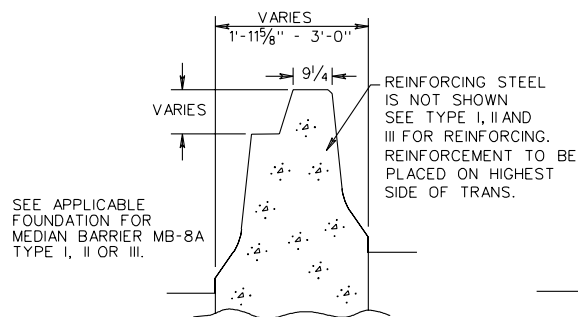

SECTION A-A
(FOUNDATION NOT SHOWN)

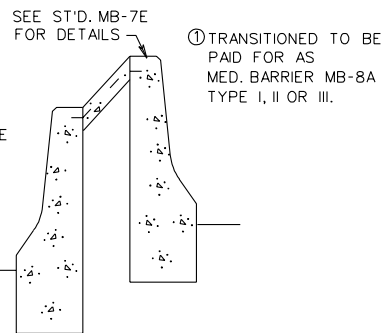

SECTION B-B
(STD. MB-7E)

FLARE RATES			
DESIGN SPEED	INSIDE SHY LINE	BEYOND SHY LINE	
MPH	SHY LINE LS	FLARE RATE	FLARE RATE
70	10'	30 : 1	20 : 1 ②
60	8'	26 : 1	17 : 1 ②
50	6.5'	21 : 1	14 : 1 ②
40	5'	17 : 1	11 : 1 ②
30	3.5'	13 : 1	8 : 1 ②

② MAXIMUM FLARE RATE FOR RIGID BARRIER SYSTEMS.

CONCRETE MEDIAN BARRIER TYPE I, II OR III

VIRGINIA DEPARTMENT OF TRANSPORTATION

501.47

SPECIFICATION
REFERENCE

105
404
502