

TYPICAL SIGN FOOTING DETAIL WITH CONDUIT

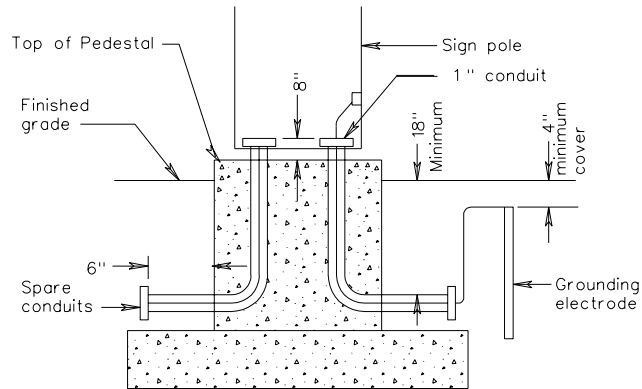

NOTES:

The type, size, number and orientation of conduits entering and exiting footings may vary per sign location.

In addition to the conduits specified on the plans, one - 1" conduit required for ground wire and two - 2" pvc heavy wall conduits required for future use. Future use conduits shall be stubbed out and capped. Future use conduits shall be oriented to run parallel to the roadway. For location of future use conduits in foundations for double end pole structures, see drawing at right.

Each foundation shall be permanently marked to indicate all sides from which conduits pass. This mark shall be made with a trowel when finishing the concrete and shall be 1/4" deep and 4" to 6" long. Locations of empty conduits shall have an additional 2" long mark made perpendicular to and centered on this mark.

Foundations above finished grade shall be chamfered 3/4" on all edges.

Grounding bushings shall be installed on each end of metal conduits.

Bell ends shall be installed on each end of PVC conduits.

Bell ends & bushings of empty conduits shall be plugged to prevent moisture and rodent entry.

Voids remaining after conductors exit or enter bell ends or bushings of conduits shall be sealed with silicone to prevent moisture and rodent entry.

No mortar, grout, or concrete shall be placed between bottom of base plate and top of pedestal.

LOCATION OF FUTURE USE CONDUITS FOR DOUBLE END POLE STRUCTURES

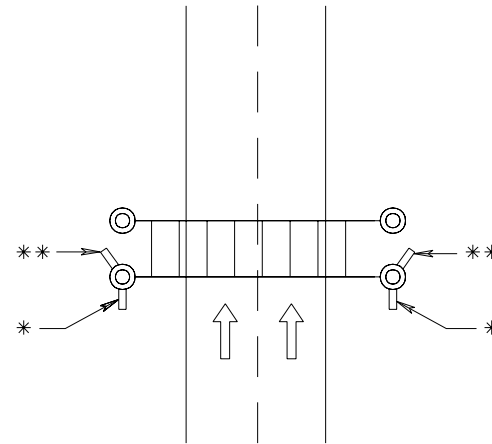

\* Future use conduits placed parallel to the roadway

\*\* Future use conduits placed at an angle to miss the back foundation or anchor bolts in a spread footing foundation.

The maximum space between the bottom of the base plate and the top of the foundation shall be no greater than the diameter of the anchor bolt plus one inch.

Overhead sign structures including "butterfly" structures shall have a minimum of six anchor bolts, each having a minimum diameter of 1/2".

TYPICAL DETAILS FOR OVERHEAD SIGN STRUCTURES

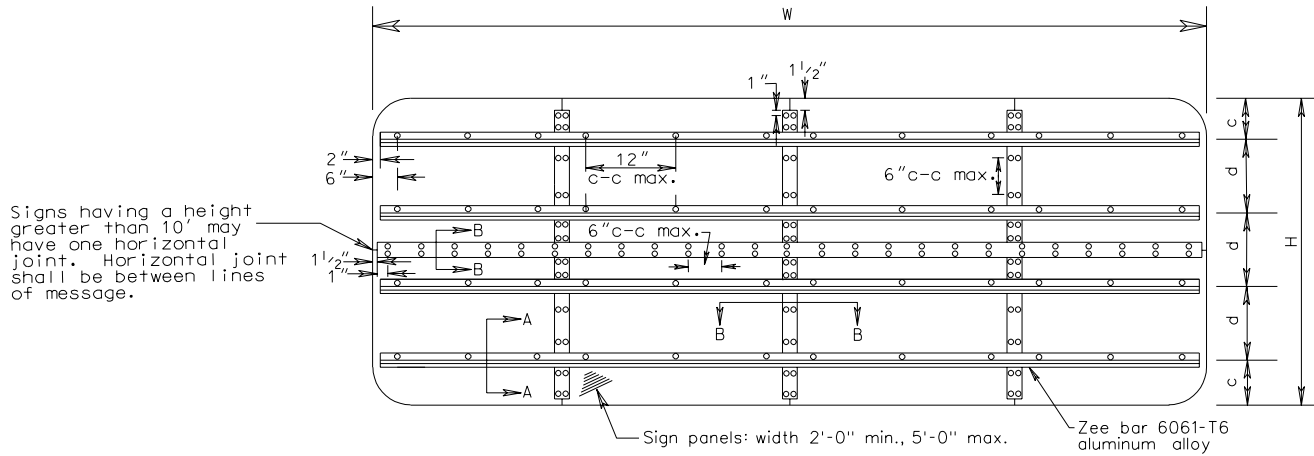

SECTION A-A

SECTION B-B

ALL INSTALLATIONS EXCEPT TOP AND BOTTOM ZEE BARS ON OVERHEAD SIGNS

TOP AND BOTTOM ZEE BAR INSTALLATION ON OVERHEAD SIGNS

3/16" diameter rivet - Rivets shall be dome head, break mandrel, blind rivets conforming to Industrial Fasteners Institute Standard IFI-114, Style 1, Grades 10 or 11 except that the minimum ultimate tensile strength shall be 360 pounds. Rivets shall have a grip range accommodating the combined thickness of the sign panel and zee bar and shall be installed in accordance with the manufacturer's recommendations.

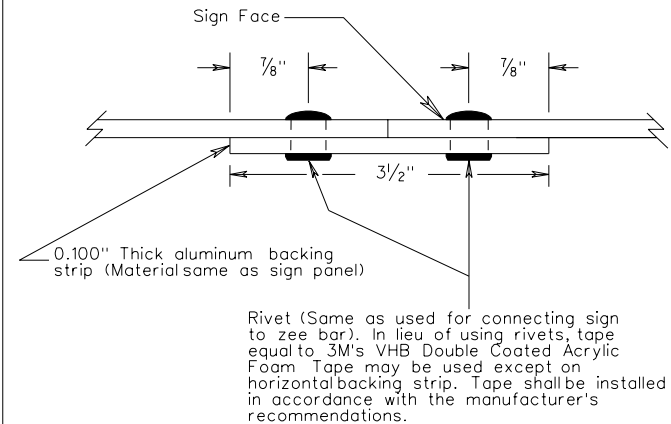
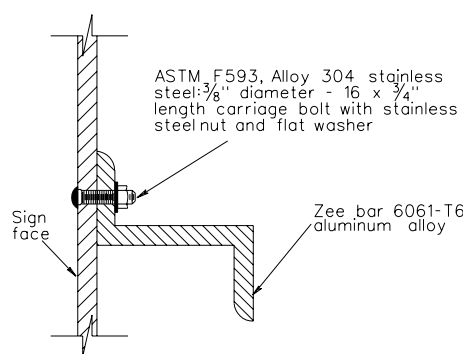
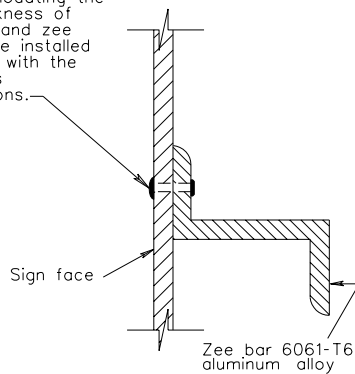

SIGN PANEL DESIGN