

REVISED ON 7/05

MB-7D,7E,7F

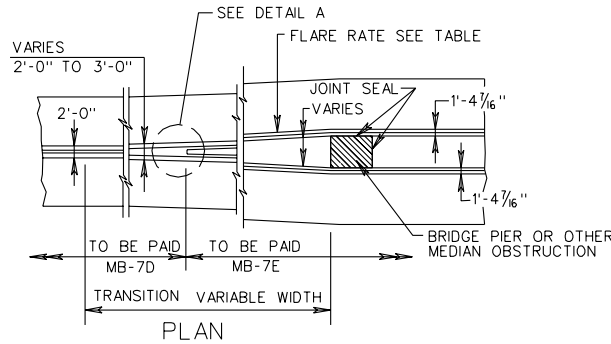

* SUGGESTED MAXIMUM FLARE RATE FOR RIGID BARRIER SYSTEMS.

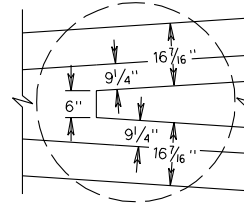

FLARE RATES			
DESIGN SPEED	INSIDE SHY LINE	BEYOND SHY LINE	
MPH	SHY LINE LS	FLARE RATE	FLARE RATE
70	10'	30:1	20:1 *
60	8'	26:1	18:1 *
50	6.5'	21:1	14:1 *
40	5'	16:1	10:1 *
30	3.5'	13:1	8:1 *

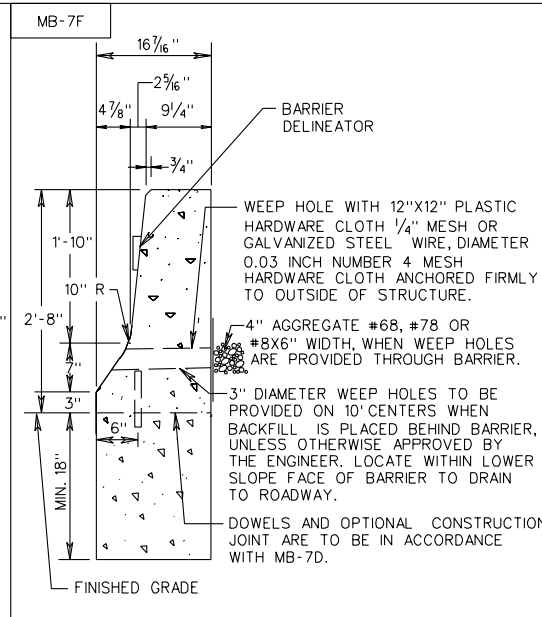
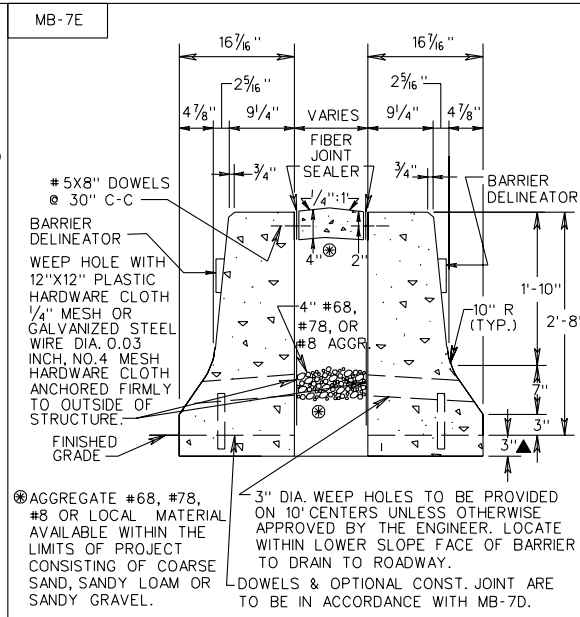
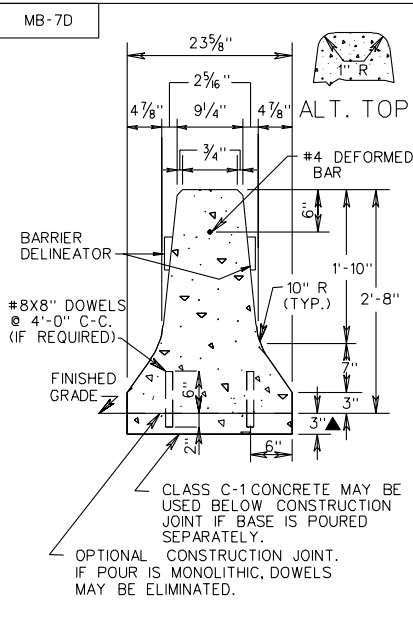

NOTES:
IF THE CONTRACTOR ELECTS TO USE THE OPTIONAL CONSTRUCTION JOINT, TRANSVERSE JOINTS FOR CRACK CONTROL AND EXPANSION JOINTS ARE TO BE PROVIDED IN BOTH FOOTING AND BARRIER AT THE SAME LOCATION.
TRANSVERSE JOINTS ARE TO COINCIDE WITH JOINTS IN ADJACENT PAVEMENT WITH A MAXIMUM SPACING OF 20 FEET C-C.
CONCRETE MEDIAN BARRIER MAY BE PRECAST, CAST IN PLACE OR SLIP-FORMED. FOR PRECAST DESIGN SEE STANDARD MB-7D PC.
HORIZONTAL REINFORCING STEEL BARS ARE TO BE SEPARATED AT ALL EXPANSION AND CONTRACTION JOINTS. A 2" CONCRETE COVER IS REQUIRED OVER THE ENDS OF THE REINFORCING STEEL.

BARRIER DELINEATOR SIZE, COLOR, AND SPACING TO BE IN ACCORDANCE WITH THE SPECIFICATIONS.
COST OF DELINEATOR TO BE INCLUDED IN THE PRICE BID FOR MEDIAN BARRIER.
REFLECTIVE SURFACE OF BARRIER DELINEATOR IN ALL INSTANCES, TO BE FACING ONCOMING TRAFFIC.
ALTERNATE TOP DESIGN SHOWN ON MB-7D. MAY ALSO BE APPLIED TO MB-7E AND MB-7F.
CONCRETE TO BE CLASS A3 IF CAST IN PLACE, 4000 PSI IF PRECAST.
▲ DEPTH OF CONCRETE BASE MAY BE EXTENDED AT THE CONTRACTOR'S OPTION TO COINCIDE WITH BOTTOM OF PAVEMENT COURSE IN WHICH BASE TERMINATES; HOWEVER, THE COST OF ADDITIONAL CONCRETE SHALL BE INCLUDED IN UNIT PRICE BID PER LINEAR FOOT OF BARRIER.

SPECIFICATION REFERENCE
105 502

CONCRETE MEDIAN BARRIER

VIRGINIA DEPARTMENT OF TRANSPORTATION

REV. 1 /04

501.44

REVISED ON 7/05

MB-7D PC

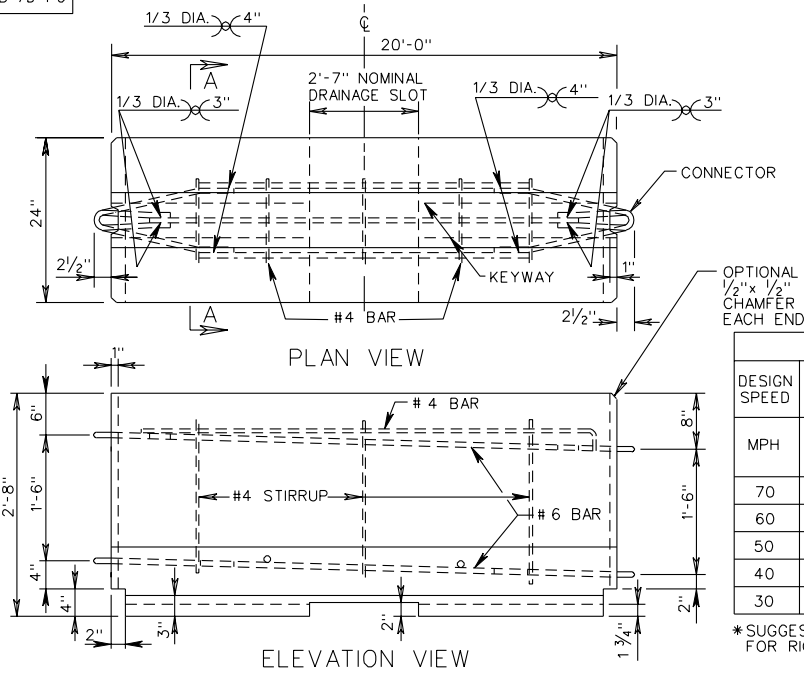

OPTIONAL
1/2" x 1/2"
CHAMFER
EACH END

DESIGN SPEED	FLARE RATES *	
	INSIDE SHY LINE	BEYOND SHY LINE
MPH	SHY LINE LS	FLARE RATE
70	10'	30:1
60	8'	26:1
50	6.5'	21:1
40	5'	16:1
30	3.5'	13:1

*SUGGESTED MAXIMUM FLARED RATE FOR RIGID BARRIER SYSTEMS.

NOTES:

- FOR POSITIVE CONNECTION DETAILS AND DIMENSIONS SEE SHEETS 501.59 - 501.61.
- AT THE OPTION OF THE MANUFACTURER, ADDITIONAL REINFORCING MAY BE ADDED TO THE PRECAST CONCRETE BARRIER FOR HANDLING.
- CONCRETE SHALL BE 4000 P.S.I. MINIMUM.
- BARRIER DELINEATOR SIZE, COLOR AND SPACING SHALL BE IN ACCORDANCE WITH THE SPECIFICATIONS.
- COST OF DELINEATOR SHALL BE INCLUDED IN THE PRICE BID FOR TRAFFIC BARRIER SERVICE.
- OTHER PRECAST TRAFFIC BARRIER SERVICE CONCRETE DESIGNS THAT MEET NCHRP 350 TEST REQUIREMENTS AND HAVE BEEN ACCEPTED BY VDOT AS AN ACCEPTABLE ALTERNATE TO THE STANDARD DESIGN MAY BE SUBSTITUTED.
- A 1" RADIUS MAY BE USED AS AN ALTERNATE FOR THE 3/4" CHAMFER.
- BARRIER DELINEATOR REFLECTIVE SURFACE IN ALL INSTANCES SHALL BE FACING ONCOMING TRAFFIC.
- BARRIER VERTICAL PANELS SHALL BE SPACED IN ACCORDANCE WITH VIRGINIA WORK AREA PROTECTION MANUAL.

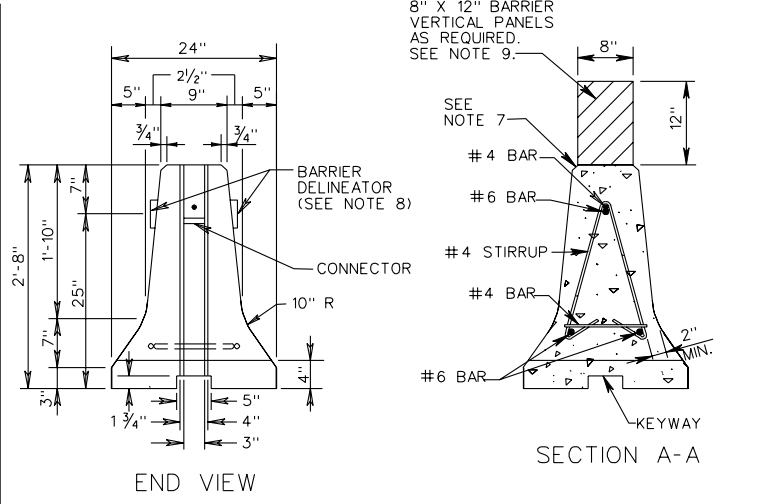
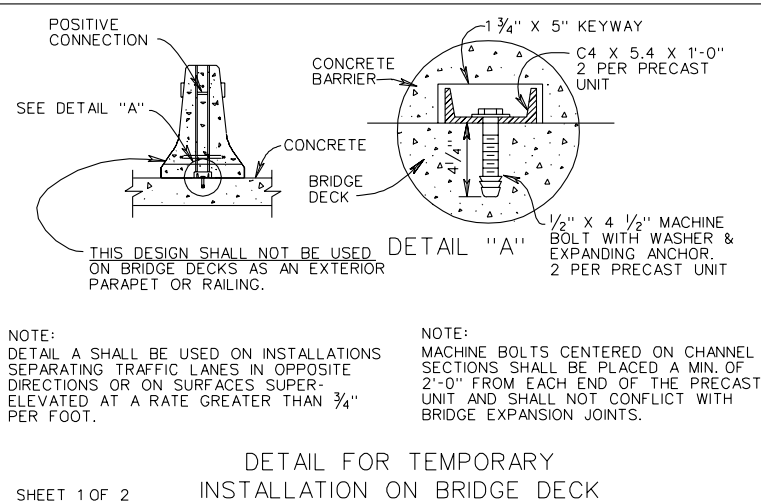

PRECAST TRAFFIC BARRIER SERVICE CONCRETE

REV.1 /04
501.45

VIRGINIA DEPARTMENT OF TRANSPORTATION

SPECIFICATION REFERENCE

105
512