

REVISED ON 7/05

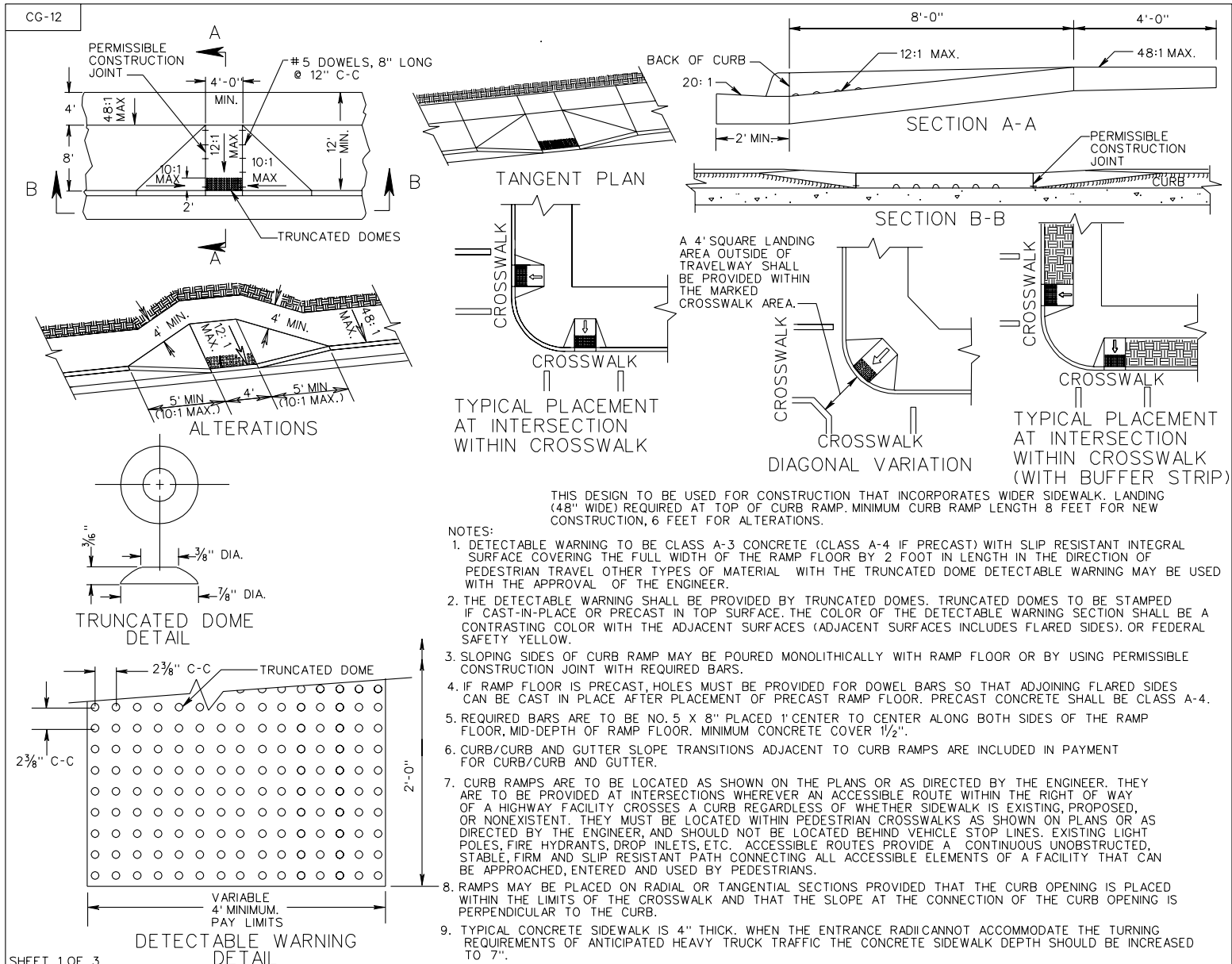

SHEET 1 OF 3

CG-12 DETECTABLE WARNING SURFACE
TYPE A (PERPENDICULAR) APPLICATION

SPECIFICATION
REFERENCE

105
502

REV. 1/04
203.05

VIRGINIA DEPARTMENT OF TRANSPORTATION

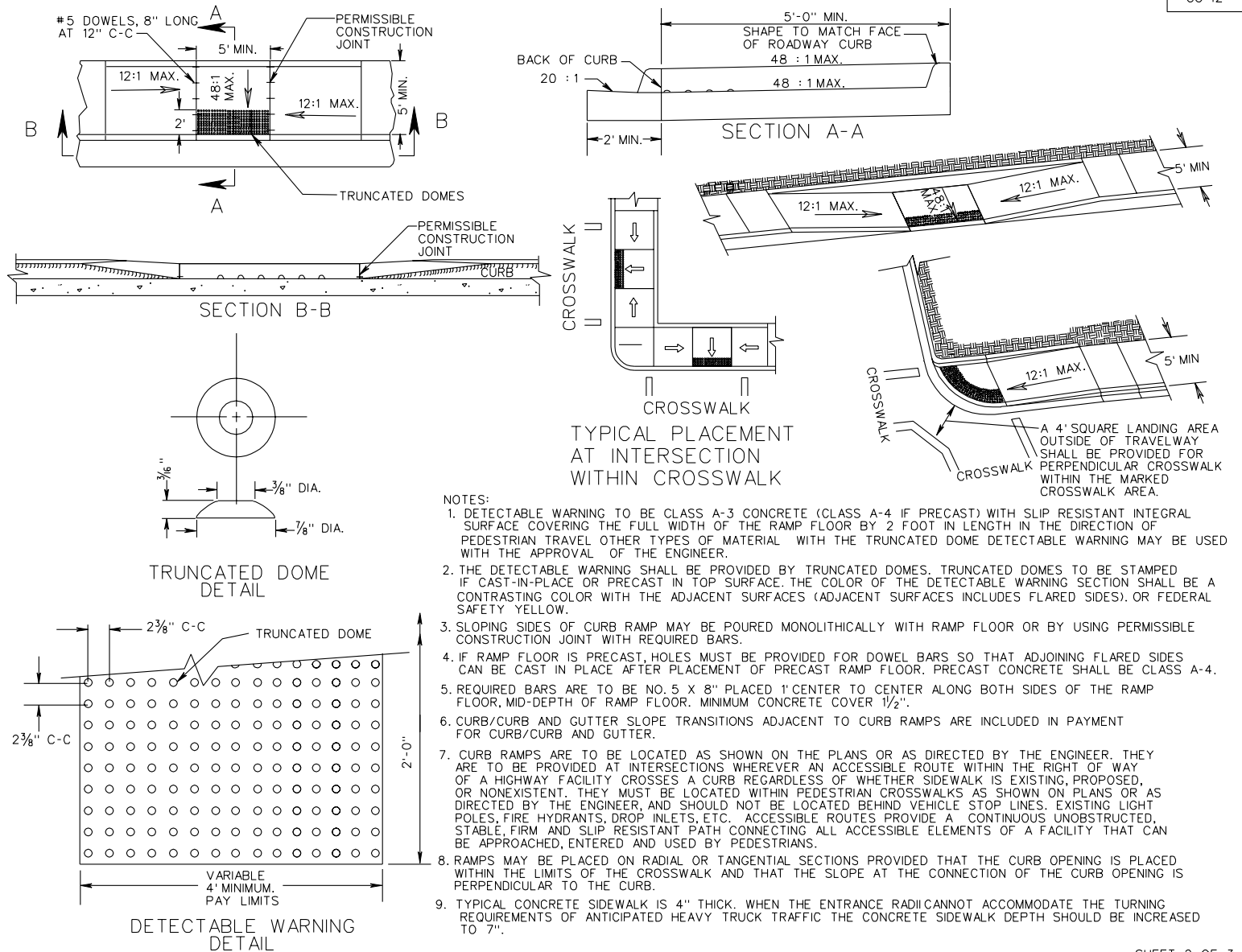

SPECIFICATION REFERENCE	<p>CG-12 DETECTABLE WARNING SURFACE TYPE B (PARALLEL) APPLICATION</p> <p>VIRGINIA DEPARTMENT OF TRANSPORTATION</p>	
105 502		REV. 1/04 203.06

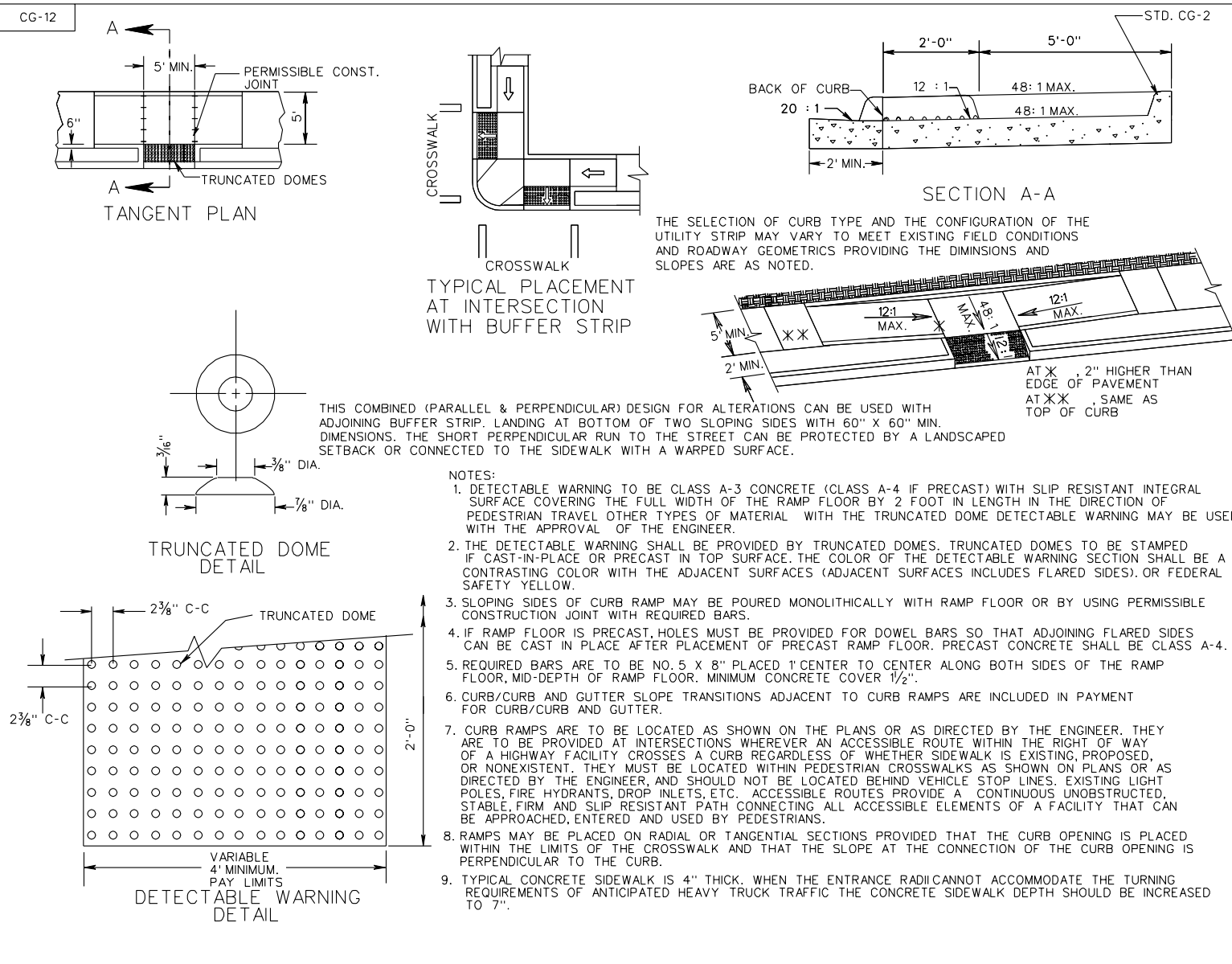

SHEET 3 OF 3

CG-12 DETECTABLE WARNING SURFACE
 TYPE C (PARALLEL & PERPENDICULAR) APPLICATION
 VIRGINIA DEPARTMENT OF TRANSPORTATION

REV. 1/04
 203.07

SPECIFICATION REFERENCE
105 502