

NOTE:
RUBRAIL MUST BE TWISTED 35° BETWEEN SECTIONS C-C AND D-D. SHOP FABRICATION MAY BE REQUIRED. RIGHT AND LEFT HAND TWISTS WILL BE REQUIRED.

- NOTES:
- ARE GUARDRAIL POSTS ARE TO BE STEEL.
 - ALL GUARDRAIL COMPONENTS ARE TO BE IN ACCORDANCE WITH VDOT ROAD AND BRIDGE STANDARDS.
 - POSTS 1, 2, 3, 4 AND 5 REQUIRE AN ADDITIONAL HOLE TO ATTACH LOWER BLOCKS AND/OR RUBRAIL. RUBRAIL IS NOT BOLTED TO POSTS 2 AND 4.
 - BOTTOM WOOD BLOCKS LOCATED ON POSTS 1 THROUGH 4 ARE TO BE DRILLED AND SECURED WITH 5/8" CARRIAGE BOLTS (LENGTH AS REQUIRED)
 - W-BEAM IS NOT BOLTED TO POSTS 2, 4, 5 AND 7. THESE BLOCKS ARE TO BE BOLTED DIRECTLY TO POSTS.
 - APPROPRIATE LENGTH 7/8" ASTM A325 HEX BOLTS ARE TO BE USED WITH HOLES DRILLED THROUGH THE CONCRETE MEDIAN BARRIER, ATTACHING THE W-BEAM TERMINAL CONNECTORS ON EACH SIDE.

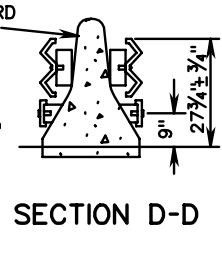
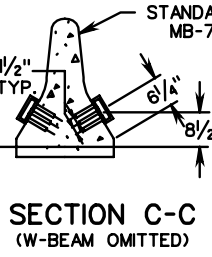
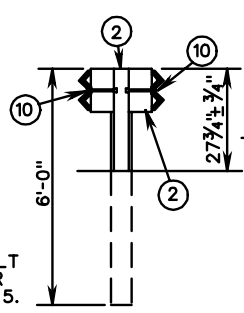
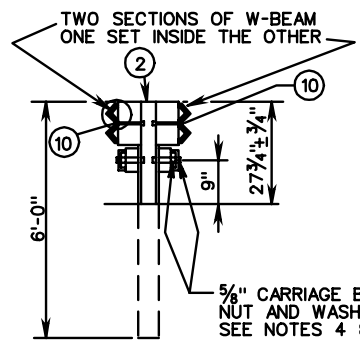

SECTION A-A
(ONE RAIL OMITTED)

SECTION B-B
(ONE RAIL OMITTED)

RUBRAIL WOOD BLOCKS 7" x 4"	
POST	THICKNESS
1	4 1/4"
2	3 3/4"
3	2"
4	1"

ITEM	MATERIALS/SPECIFICATIONS/NOTES
1	5/8" WASHER
2	ST'D. W6 X 8.5 OR W6 X 9 STEEL POSTS, ST'D. 6" X 8" X 14" LONG TREATED PINE BLOCK OR RE-CYCLED MATERIAL.
3	ST'D. W-BEAM TERMINAL CONN. (MOD.)
4	STANDARD W-BEAM RAIL
5	5/8" X 2" LG. GUARDRAIL BOLT AND RECESSED NUT

ITEM	MATERIALS/SPECIFICATIONS/NOTES
6	RECTANGULAR PLATE WASHER (SEE STANDARD GR-HDW)
7	BENT PLATE (SEE SHEET 2 OF 2)
8	C6 x 8.2 RUBRAIL (SEE SHEET 2 OF 2)
9	WOOD BLOCKOUT FOR RUBRAIL (SEE SHEET 2 OF 2)
10	5/8" x 10" LONG HEX BOLT WITH NUT

- TYPE I TWO RUN-ON SECTIONS (WITH 2 RUBRAILS SHOWN)
- TYPE II ONE RUN-ON SECTION WITH 1 RUBRAIL RETAINED) ONE RUN-OFF SECTION (WITH 1 RUBRAIL REMOVED)
- TYPE III TWO RUN-OFF SECTIONS (WITH 2 RUBRAILS REMOVED)

BLOCKED-OUT W-BEAM MEDIAN BARRIER-FIXED OBJECT ATTACHMENT FOR USE BETWEEN STANDARD MB-7 AND STANDARD MB-3