

PLAN VIEW

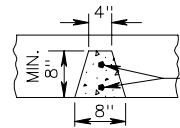

MINIMUM 2 BARS PER BEAM
HAVING A MINIMUM TOTAL
WEIGHT OF 2.004 LBS. PER FT.

SECTION B-B
TYPICAL BEAM SECTION

NOTES:
ANY MANUFACTURERS FABRICATION MEETING OR EXCEEDING
THE MINIMUM DESIGN REQUIREMENTS DETAILED HEREON
WILL BE ACCEPTABLE.
ALL CONCRETE IN PRECAST MEMBERS TO BE 4000 PSI
CONCRETE IN FOOTING TO BE CLASS C1 OR CLASS A3.
LENGTH TO BE AS SHOWN ON PLANS.

MINIMUM SECTIONAL AREA
OF MEMBERS

- INTERMEDIATE RAIL — 28 SQ. IN.
- SIDE RAIL — 50 SQ. IN.
- BEAM — 48 SQ. IN.

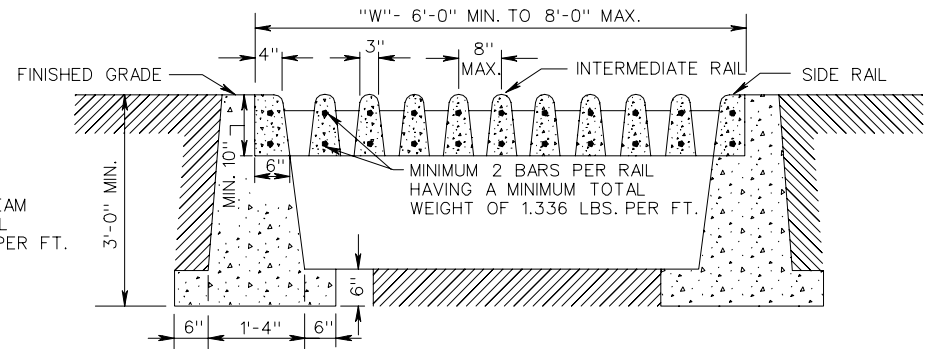

SECTION A-A

SPECIFICATION
REFERENCE

302

PRECAST CONCRETE CATTLE GUARD

VIRGINIA DEPARTMENT OF TRANSPORTATION