

CONNECTOR PIN ASSEMBLY
GALVANIZE AFTER FABRICATION.

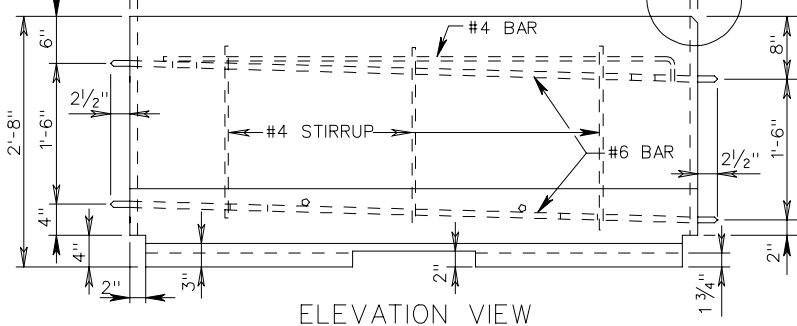

END VIEW

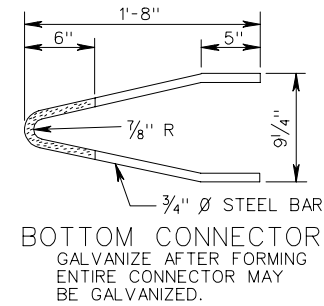
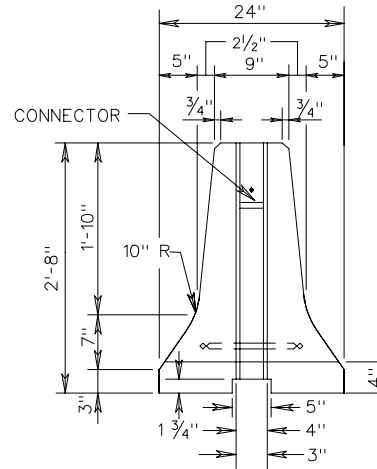
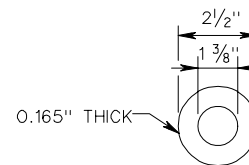

PLAIN GALVANIZED STEEL WASHER FOR 1 1/4" PIN

NOTES:

- PIN AND CONNECTORS ARE TO BE ASTM A-36 REINFORCING. STEEL BARS ARE TO BE ASTM A 615, GRADE 60. ONE CONNECTOR PIN ASSEMBLY WITH EACH BARRIER SECTION.
- THE CONNECTION PIN, NUTS AND WASHERS SHALL BE GALVANIZED IN ACCORDANCE WITH AASHTO M-111.
- BEGINNING WITH THE JANUARY 2000 ADVERTISEMENT, ALL POSITIVE CONNECTIONS MUST BE APPROVED BY THE FHWA IN ACCORDANCE WITH NCHRP 350 TEST REQUIREMENTS.

WHEN USING VDOT STANDARD MB-7D PC WITH THE PIN AND LOOP POSITIVE CONNECTION, ALLOW FOR A 6'-0" DYNAMIC DEFLECTION. PROVIDE MIN. 60' OF BARRIER UPSTREAM AND DOWNSTREAM OF WORK ZONE FOR ANCHORAGE. FOR APPROVED NON-VDOT DESIGNS, REFER TO MANUFACTURER'S INSTALLATION INSTRUCTIONS FOR DEFLECTIONS AND ANCHORAGE.

PIN AND LOOP DETAILS

PRECAST CONCRETE MEDIAN BARRIER POSITIVE CONNECTION OPTIONS