

BARRIER TAPER FROM 50" TALL F-SHAPE TO A STANDARD MB-7A OR MB-7D BARRIER TO BE ACCOMPLISHED WITHIN THE 6'-0" AS INDICATED.

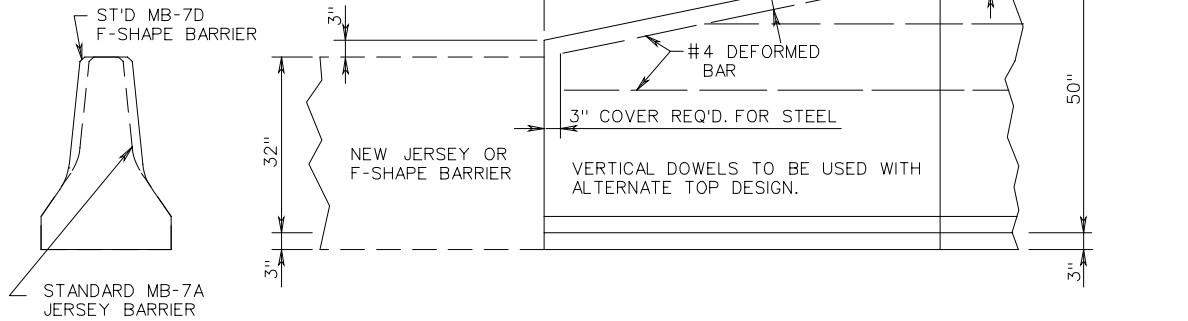

TRANSITION FROM 50" TALL WALL TO 32" JERSEY OR F-SHAPE BARRIER

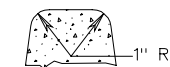
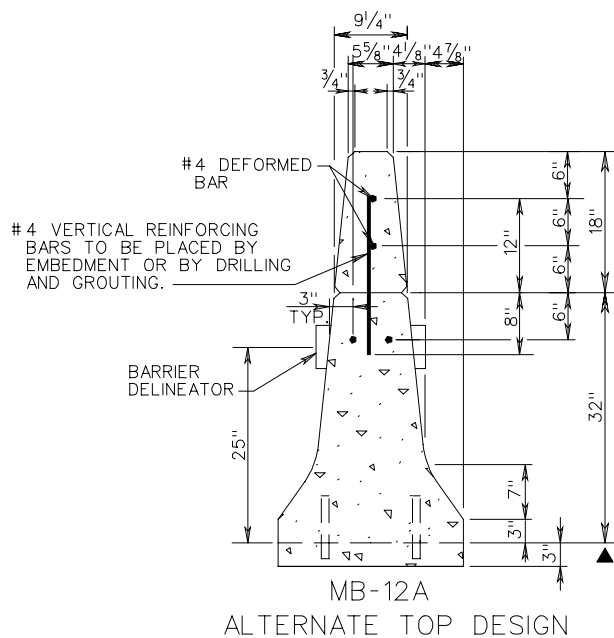

DETAIL B

THE ALTERNATE DESIGN OF 1" R MAY ALSO BE USED FOR MB-12A, 12B OR 12C.

OPTIONAL CONSTRUCTION JOINT. IF POUR IS MONOLITHIC, DOWELS MAY BE ELIMINATED.

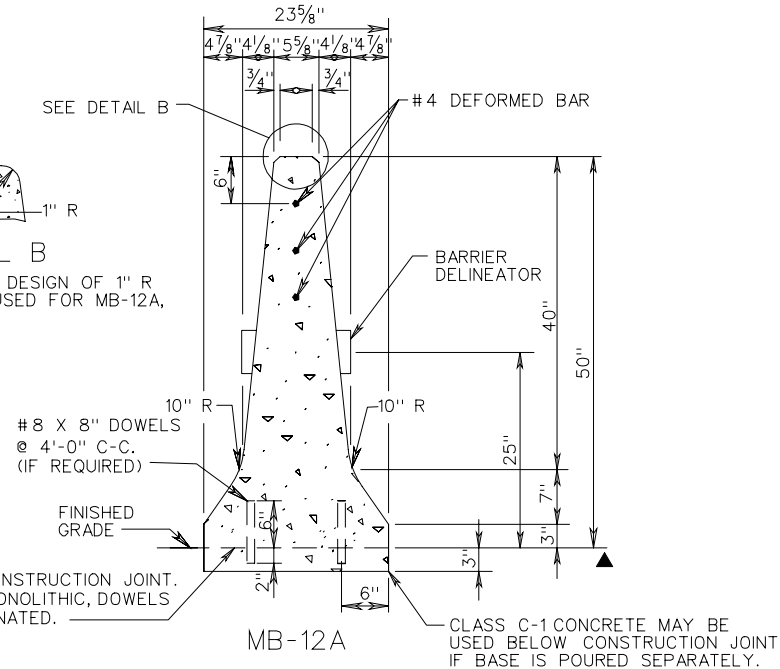

IF BARRIER EXTENSION IS CONSTRUCTED AS A SEPARATE ITEM, ALL JOINTS ARE TO BE CONSTRUCTED AT THE SAME INTERVAL AS CONCRETE BARRIER. ALL VERTICAL BARS ARE #4 AT 24" MAX. SPACING. LENGTH OF DOWELS SHALL BE 20". VERTICAL BARS MAY BE PLACED IN THE CONCRETE OR BONDED INTO DRILLED HOLES IN HARDENED CONCRETE. WHEN HOLES ARE DRILLED NON-SHRINK GROUT SHALL BE USED TO BOND THE BARS IN PLACE.

▲ DEPTH OF CONCRETE BASE MAY BE EXTENDED AT THE CONTRACTOR'S OPTION TO COINCIDE WITH BOTTOM OF PAVEMENT COURSE IN WHICH BASE TERMINATES; HOWEVER, THE COST OF ADDITIONAL CONCRETE SHALL BE INCLUDED IN UNIT PRICE BID PER LINEAR FT. OF BARRIER.

CONCRETE MEDIAN BARRIER (TALL WALL)

VIRGINIA DEPARTMENT OF TRANSPORTATION

SPECIFICATION REFERENCE

105
502