

GUARDRAIL-TUBULAR RAIL SPLICE

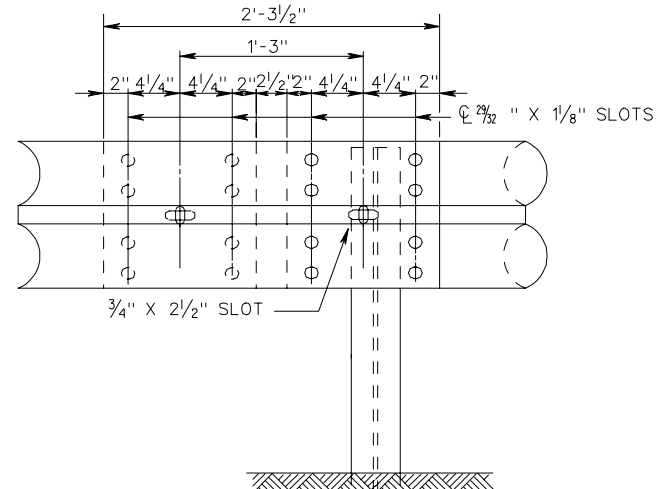

TUBULAR RAIL SPLICE

NOTES:
 TUBULAR W-BEAM RAIL MEMBER IS TO BE FABRICATED FROM STANDARD 25' NOMINAL W-BEAM SECTIONS. TOP AND BOTTOM SEAMS SHALL BE BUTT WELDED 6" AT 12" SPACING. CONTINUOUS SEAM WELDING IS ALSO ACCEPTABLE. WELDS SHALL BE CHIPPED AND CLEANED AND THE COMPLETE 25 FT. TUBULAR MEMBER SHALL BE GALVANIZED AFTER FABRICATION. FOR TUBULAR RAIL SPLICE ADDITIONAL POST MOUNTING SLOTS ARE TO BE MADE IN EACH MEMBER 1'-3" FROM THE STANDARD SLOTS AT 6'-3" CENTERS.

8-5/8" SPLICE NUTS SHALL BE TACK WELDED TO A BENT SHEET METAL POSITIONER AS SHOWN. OTHER SUITABLE POSITIONING METHODS OR DEVICES MAY BE SUBSTITUTED. THE COMPLETED SPLICE SHALL HAVE 8 BOLTS (16 BOLTS IF A TUBULAR RAIL SPLICE). EACH BOLT WILL INCLUDE A 1 3/4" X 3" X 3/16" PLATE WASHER OR A 2 INCH DIAMETER WASHER.

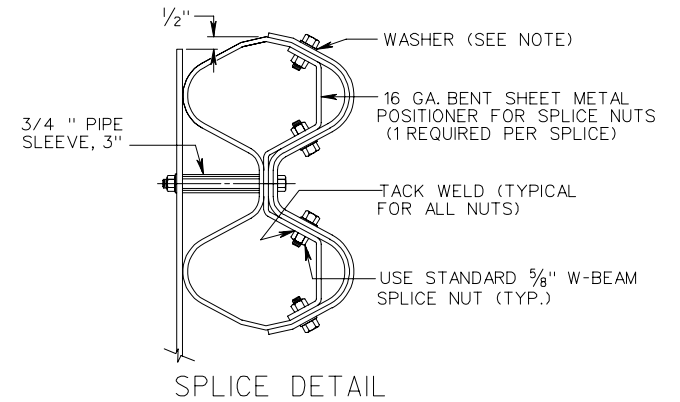

SPLICE DETAIL