

PLAN

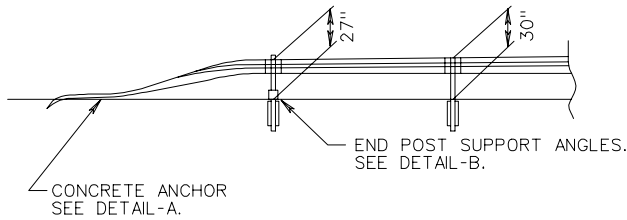

ELEVATION

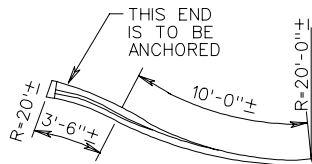

SHOP BENDING AND TWISTING REQUIRED TO MAKE THE ANCHOR TREATMENT.

DETAIL-C  
SHOP CURVED RAIL

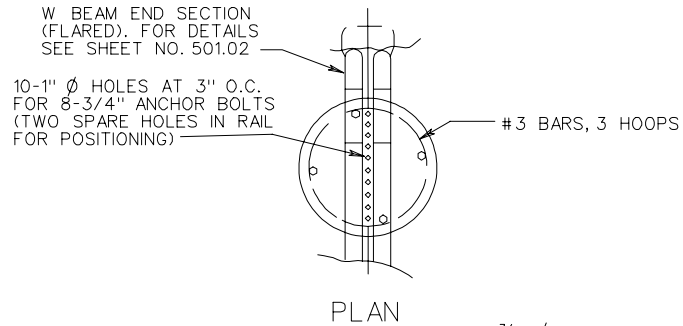

PLAN

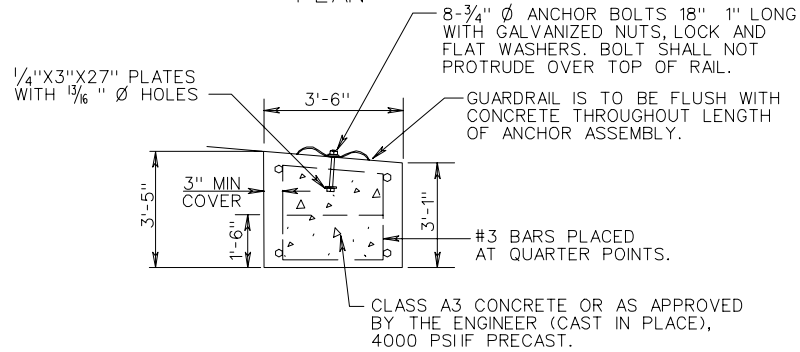

ELEVATION

DETAIL-A  
CONC. ANCHOR  
ASSEMBLY

13/16" Ø HOLES FOR 3/4" BOLTS 4 1/2" LONG WITH NUTS AND WASHERS. BOLTS TORQUED TO 100 + 20 FT. LBS. AFTER POST IS DRIVEN.

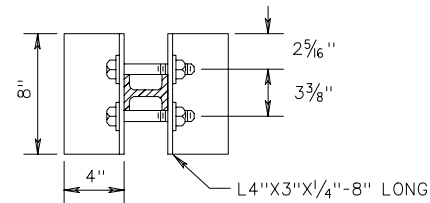

DETAIL-B  
END POST SUPPORT ANGLES

GR-8 TYPE II TERMINAL TREATMENT  
(RUN-OFF ANCHORAGE)

STANDARD W BEAM GUARDRAIL (WEAK POST SYSTEM)