

TYPICAL INSTALLATION

STANDARD	POST SPACING	DEFLECTION
GR-8	12' - 6"	7' - 0"
GR-8A	6' - 3"	5' - 0"
GR-8B	3' - 1 1/2"	4' - 0"
GR-8C	4' - 2"	4' - 6"

FOR ROCK INSTALLATION, 8" X 24" X 1/4" PLATE IS TO BE ELIMINATED. DRILL OR EXCAVATE HOLE FOR POST, PLACE POST AND BACKFILL WITH CRUSHER RUN AGGREGATE TO LEVEL OF ROCK.

ALL POSTS, BOLTS, NUTS AND WASHERS ARE TO BE GALVANIZED.

FOR DETAILS OF GUARDRAIL ELEMENT, SPLICE JOINT, HARDWARE, ETC. SEE SHEET NO. 501.01.

⊗ THE GUARDRAIL AND MEDIAN BARRIER COMPONENTS DEPICTED IN A.R.T.B.A. TECHNICAL BULLETIN NUMBER 268B MAY BE SUBSTITUTED IF INTERCHANGEABLE WITH THE STANDARDS FOR GUARDRAIL (GR) OR MEDIAN BARRIER (MB) AND APPROVED BY THE ENGINEER.

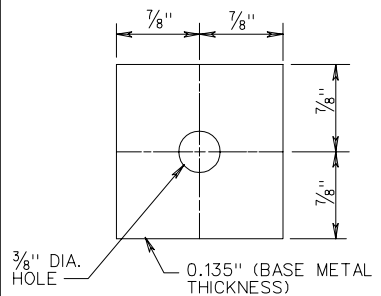

SQUARE WASHER

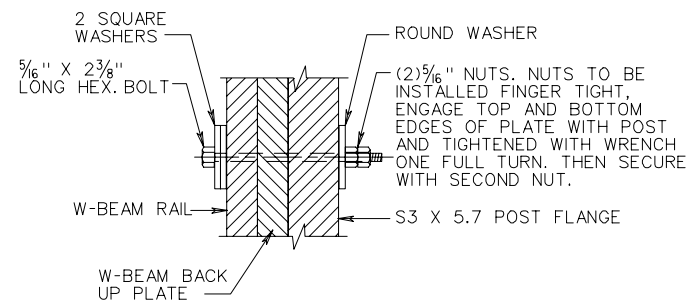

GUARDRAIL POST CONNECTION DETAIL

POST SPACING ON CURVES	
PAVEMENT ϕ RADIUS	POST SPACING
> 220 FT. R	12' - 6"
219 FT. - 111 FT.	6' - 3"
110 FT. - 76 FT.	4' - 2"
75 FT. - 50 FT.	3' - 1 1/2"
< 50 FT.	USE NOT RECOMMENDED

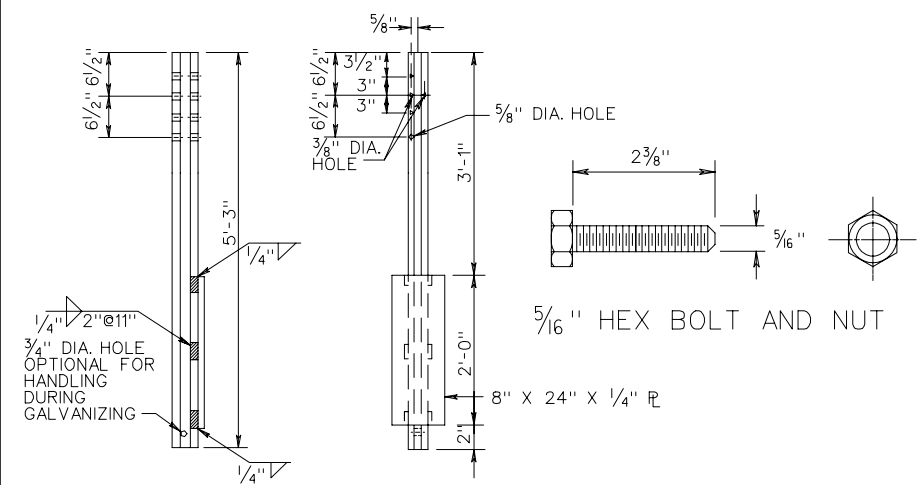

S 3 X 5.7 STEEL POST

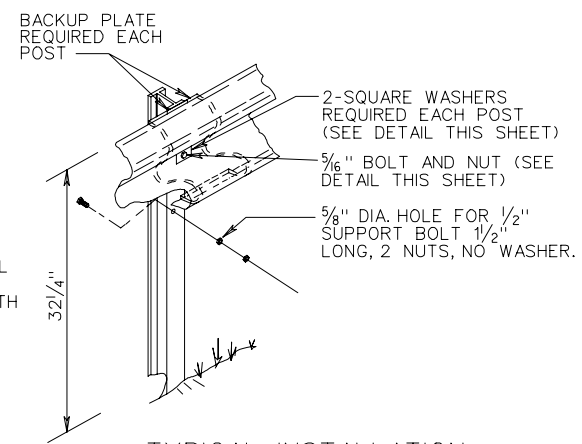

TYPICAL INSTALLATION

SPECIFICATION REFERENCE
221 505

STANDARD W BEAM GUARDRAIL (WEAK POST SYSTEM)
 TL-3 (>45 MPH)
 VIRGINIA DEPARTMENT OF TRANSPORTATION

SHEET 1 OF 2
 REV. 7/03
 501.14