

SOIL RETENTION MAT

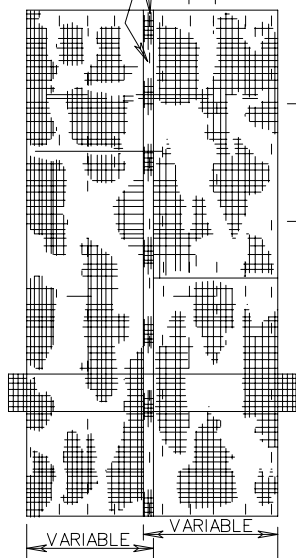

PLAN VIEW STAPLING DIAGRAM

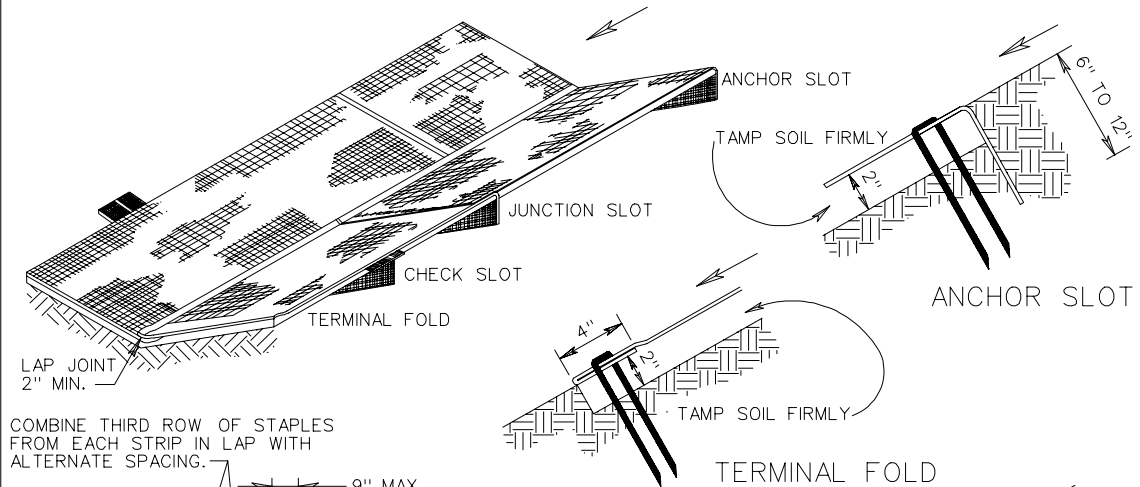
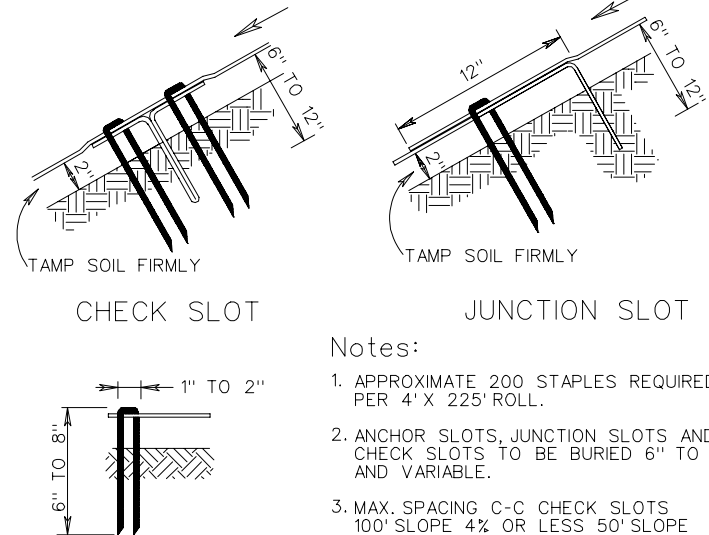

JUTE MESH

Notes:

1. APPROXIMATE 200 STAPLES REQUIRED PER 4' X 225' ROLL.
2. ANCHOR SLOTS, JUNCTION SLOTS AND CHECK SLOTS TO BE BURIED 6" TO 12" AND VARIABLE.
3. MAX. SPACING C-C CHECK SLOTS 100' SLOPE 4% OR LESS 50' SLOPE STEEPER THAN 4%.
4. STAPLES FORMED FROM NO. 8 STEEL WIRE 8" STAPLE MINIMUM LENGTH FOR SANDY SOIL 6" STAPLE MINIMUM LENGTH FOR OTHER SOIL.

GENERAL NOTES:

1. BASIS OF PAYMENT TO BE SQUARE YARDS OF PROTECTIVE COVERING COMPLETE IN PLACE. PROTECTIVE COVERING IS TO BE LOCATED AS INDICATED ON THE PLANS IN ACCORDANCE WITH THE DIMENSIONS SPECIFIED ON TYPICAL SECTION.
2. "T-TOP" STAPLES OR OTHER MANUFACTURER'S DESIGN APPROVED BY THE ENGINEER MAY BE SUBSTITUTED FOR THE STAPLES SHOWN.
3. JUTE MESH OR SOIL RETENTION MAT IN ACCORDANCE WITH THE SPECIFICATIONS MAY BE USED AT THE OPTION OF THE CONTRACTOR.
4. WIDTH OF MATERIAL MAY VARY FROM MINIMUM DIMENSION BY INCREMENTS OF 4 OR 5 FEET.
5. FOR SOURCES OF APPROVED MATERIAL SEE VDOT'S APPROVED PRODUCTS LIST FOR ST'D. EC-2 MATERIAL.

PROTECTIVE COVERING INSTALLATION CRITERIA

SPECIFICATION REFERENCE

244  
606